

User's and Programming Guide
Agilent Technologies
ESG Family Signal Generators
Options:
UND, Dual Arbitrary Waveform Generator
UN5, Multichannel, Multicarrier CDMA Personality

Serial Number Prefixes:

(Affix Label Here)



Part No. E4400-90328

Printed in USA
October 2000

Supersedes June 2000

© Copyright 1999, 2000 Agilent Technologies

Contents

1. The Dual Arbitrary Waveform Generator

Overviews	1-2
Specifications	1-2
Dual Arbitrary Waveform Generator (Option UND)	1-2
Multichannel, Multicarrier CDMA Personality (Option UN5)	1-4

2. Using Functions

Table Editor Basics	2-2
Creating Custom CDMA States	2-3
Setting up a CDMA Template	2-3
Modifying a CDMA Template	2-4
Applying a Custom Channel Setup, then Activating the Custom CDMA State and Applying it to the RF Output	2-7
Clipping a CDMA Waveform	2-8
Viewing Code Domain Power and Waveform Statistics	2-9
Storing a Custom CDMA State to Memory	2-11
Recalling Custom CDMA States	2-13
Creating Custom Multicarrier CDMA Waveforms	2-15
Opening the Multicarrier CDMA Setup Table Editor	2-15
Modifying a Multicarrier CDMA 3-Carrier Template	2-17
Applying and Activating the Custom Multicarrier CDMA Setup	2-21
Applying the Custom Multicarrier CDMA Waveform to the RF Output	2-22
Storing a Custom Multicarrier CDMA Waveform	2-23
Recalling Custom Multicarrier CDMA Waveforms	2-25
Setting Up Predefined Single Carrier Digital Modulation	2-27
Setting Up Custom Single Carrier Digital Modulation	2-29
Setting Up a Multicarrier Digital Modulation	2-33
Creating a User-Defined FIR Filter Using the FIR Table Editor	2-35
Accessing the Table Editor	2-35
Entering the Coefficient Values	2-36
Duplicating the First 16 Coefficients Using Mirror Table	2-37
Setting the Oversample Ratio	2-37
Displaying a Graphical Representation of the Filter	2-38
Storing the Filter to Memory	2-39
Modifying a FIR Filter Using the FIR Table Editor	2-40
Loading a Default Gaussian FIR File	2-40
Modifying the Coefficients	2-41
Storing the Filter to Memory	2-42
Applying a User-Defined FIR Filter to a CDMA State	2-43
Using External Reconstruction Filters	2-45
Using the Multitone Waveform Generator	2-46
Creating a Multitone Waveform	2-47
Using a Stored Multitone Waveform	2-52
Building a Waveform Sequence	2-54
Generating the First Waveform	2-54
Renaming the First Waveform as a Waveform Segment	2-55
Generating the Second Waveform	2-56
Renaming the Second Waveform as a Waveform Segment	2-56
Building a Waveform Sequence from Two Waveform Segments	2-57

Contents

Editing the First and Second Waveform Segment Repetitions	2-58
Naming and Storing the Waveform Sequence	2-59
Playing the Waveform Sequence	2-60
Using Markers	2-61
Placing Markers on a Waveform Segment	2-61
Using Markers in a Waveform Sequence	2-65
Scaling Waveform Segments	2-68
Clipping Waveform Segments	2-70
Downloading Waveform Files Into Memory	2-72
Downloading Waveform Files Into ARB Memory	2-72
Sample Command Line	2-72
Example 1	2-73
Querying the Waveform Data	2-73
Waveform Downloading Using BASIC for Windows™	2-73
Waveform Downloading HP BASIC for UNIX	2-75
Transferring Waveforms Between ARB and NVARB Memory	2-77
Selecting a Waveform and Activating the Modulation via GPIB	2-78
Viewing Files Stored in the Memory Catalog	2-79
Creating Additive White Gaussian Noise (AWGN) Waveforms	2-80
Using Arbitrary Waveform Generator Triggers	2-81
Creating an Externally Triggered Custom Multicarrier CDMA Waveform	2-81
Controlling Waveform Sequence Playback Using Segment Advance Triggering	2-86
Setting Up a Bluetooth Signal	2-93
Accessing the Bluetooth Setup Menu	2-93
Setting Up Packet Parameters	2-93
Setting up Impairments	2-95
Using Burst	2-96
Setting the Burst Power Ramp	2-97
Using Clock/Gate Delay	2-97
Turning On a Bluetooth Signal	2-97

3. Softkey Reference

Mode Key	3-2
p/4 DQPSK2	3-3
# of Carriers	3-3
# Skipped Points	3-3
2-Lvl FSK	3-4
2.500 MHz	3-4
4-Lvl FSK	3-4
4QAM	3-4
8.000 MHz	3-4
8 Bit Pattern	3-5
8-Lvl FSK	3-5
8PSK	3-5
9 Ch Fwd	3-5
16-Lvl FSK	3-6
16PSK	3-6
16QAM	3-6
32 Ch Fwd	3-6

Contents

32QAM	3-7
64 Ch Fwd	3-7
64QAM	3-7
250.0 kHz	3-7
256QAM	3-8
16384	3-8
32768	3-8
65536	3-8
131072	3-8
262144	3-8
524288	3-8
1048576	3-8
Adjust Code Domain Power	3-9
AM_ADDR	3-9
APCO 25 C4FM	3-9
APCO 25 w/C4FM	3-9
APCO 25 w/CQPSK	3-10
Apply Channel Setup	3-10
Apply Multicarrier	3-10
Apply Multitone	3-10
Apply to Waveform	3-11
ARB Off On	3-12
ARB Reference Ext Int	3-12
ARB Sample Clock	3-12
ARB Setup	3-12
AWGN	3-13
AWGN Off On	3-13
Bandwidth	3-13
BD_ADDR	3-14
Beta	3-14
Bluetooth	3-14
Bluetooth Off On	3-14
BPSK	3-15
Build New Waveform Sequence	3-15
Burst Off On	3-15
Burst Power Ramp	3-15
Bus	3-16
C4FM	3-16
Carrier Setup	3-16
CDMA Define	3-16
CDMA Formats	3-16
CDMA Off On	3-17
CDPD	3-17
Chip Rate	3-17
Clip I+jQ To	3-18
Clip I To	3-18
Clip Q To	3-18
Clip At PRE POST FIR Filter	3-19
Clipping	3-19

Contents

Clipping Type $ I+jQ $ $ I , Q $	3-19
Clock/Gate Delay	3-20
C/N [1 MHz]	3-20
Continuous	3-20
Continuous PN9	3-21
Custom CDMA Carrier	3-21
Custom CDMA Multicarrier	3-21
Custom CDMA State	3-21
Custom Digital Mod State	3-22
D8PSK	3-22
DECT	3-22
Define User FIR	3-22
Delete All ARB Files	3-23
Delete All NVARB Files	3-23
Delete All Rows	3-23
Delete File	3-23
Delete Row	3-23
Delete Segment	3-24
Delete Selected Waveform	3-24
Delete Waveform Sequence	3-24
Digital Mod Define	3-24
Digital Modulation Off On	3-24
Display Code Domain Power	3-25
Display FFT	3-26
Display Impulse Response	3-26
Done	3-27
Done Inserting	3-27
Drift Deviation	3-27
Dual Arb	3-27
EDGE	3-28
Edit Channel Setup	3-28
Edit Item	3-28
Edit Repetitions	3-29
Edit Selected Waveform Sequence	3-29
Enter	3-29
Equal Powers	3-29
Ext	3-29
Ext Delay Off On	3-30
Ext Delay Time	3-30
Ext Polarity Neg Pos	3-31
Filter	3-31
Filter Alpha	3-31
Filter BbT	3-32
Filter Factor N/A	3-33
Filter Symbols	3-33
First Mkr Point	3-34
Freq Dev	3-35
Freq Drift Type Linear Sine	3-35

Contents

Freq Offset	3-35
Freq Spacing	3-36
FSK	3-36
Gate Active Low High.	3-37
Gate Active N/A.	3-37
Gated	3-37
Gaussian	3-38
Generate	3-38
Goto Bottom Row.	3-39
Goto Middle Row	3-39
Goto Row	3-39
Goto Top Row.	3-39
Gray Coded QPSK.	3-39
GSM.	3-39
Hamming	3-40
Hann	3-40
Impairments	3-40
Impairments Off On	3-40
Initialize Phase Fixed Random	3-40
Initialize Table	3-41
Insert Row	3-41
Insert Selected Waveform.	3-41
Insert Waveform	3-41
Insert Waveform Sequence Contents.	3-42
IS-95.	3-42
IS-95 and IS-2000	3-42
IS-95A	3-42
IS-95 Mod.	3-43
IS-95 Mod w/EQ	3-43
IS95 OQPSK	3-43
IS95 QPSK.	3-44
IS-95 w/EQ.	3-44
IS-97 Levels.	3-44
IS-2000 SR3 DS.	3-44
Kaiser.	3-44
Last Mkr Point	3-45
Load Default FIR	3-46
Load From Selected File	3-46
Load Store	3-46
Load/Store	3-46
Marker 1 2.	3-47
Marker Polarity Neg Pos.	3-47
Mirror Table	3-47
Mkr 2 To RF Blank Off On	3-47
Mod Index	3-48
Modulation Type	3-48
MSK.	3-48
MTONE	3-48
Multicarrier Define	3-48

Contents

Multicarrier Off On	3-49
Multitone	3-49
Multitone Off On	3-49
NADC	3-49
Name And Store	3-50
Next PN Offset	3-50
Noise Seed	3-50
Noise Seed Fixed Random	3-50
None	3-50
Number of Tones	3-51
Nyquist	3-51
Optimize FIR For EVM ACP	3-52
OQPSK	3-52
Oversample Ratio	3-52
Packet (DH1)	3-53
Page Down	3-53
Page Up	3-53
Paging	3-53
Payload Data	3-54
PDC	3-54
PHS	3-54
Pilot (Setup Select)	3-54
Plot CCDF	3-55
PN Offset	3-55
Previous PN Offset	3-56
Primary Key	3-56
PSK	3-56
PWT	3-56
QAM	3-56
QPSK	3-57
QPSK and OQPSK	3-57
Random	3-57
Random Seed Fixed Random	3-57
Reconstruction Filter	3-58
Rectangle	3-58
Reference Freq	3-58
Rename Segment	3-59
Restore Default Filter	3-59
Retrigger Mode Off On	3-59
Reverse	3-60
Root Nyquist	3-60
Scale To 0dB	3-61
Scaling	3-61
Secondary Key	3-61
Segment Advance	3-61
Select	3-62
Select File	3-62
Select Waveform	3-62
Select Waveform (ARBI: <i>or</i> SEQ:)	3-62

Contents

Set Marker Off All Points	3-63
Set Marker Off Range of Points	3-63
Set Marker On First Point	3-63
Set Marker On Range of Points	3-64
Set Markers	3-64
Set Scaling	3-64
Setup Select	3-65
Show Waveform Sequence Contents	3-66
Single	3-66
Sort	3-66
Sort Table	3-67
Store All	3-67
Store Custom CDMA State	3-67
Store Custom Dig Mod State	3-68
Store Custom Multicarrier	3-68
Store Segment	3-69
Store To File	3-69
Symbol Rate	3-69
Symbol Timing Err	3-70
Sync	3-70
TETRA	3-70
Through	3-70
Toggle Marker 1	3-70
Toggle Marker 2	3-71
Toggle Markers	3-71
Toggle State	3-71
Traffic	3-71
Trigger	3-71
Trigger Key	3-72
Trigger Setup	3-72
Trigger Source	3-72
Truncated PN9	3-73
User FIR	3-73
Walsh Code	3-73
Waveform Length	3-73
Waveform Segments	3-74
Waveform Sequences	3-74
Waveform Statistics	3-74
Waveform Utilities	3-74
WCDMA	3-75
Window	3-75

4. Operation

RF Modulation with Option UND	4-2
Clock Generator	4-2
Sequencer	4-2
I RAM, Q RAM, and Nonvolatile RAM	4-2
Digital-to-Analog Converter and Filtering Hardware	4-2
I/Q Modulator	4-2

Contents

RF Hardware	4-3
Managing Volatile and Non-Volatile ARB Memory	4-4
Understanding Arbitrary Waveform Memory Types	4-4
Understanding Volatile ARB Waveform Memory	4-5
Waveform Composition	4-6
Event Markers and Sequencing	4-6
Waveform Limitations	4-7
Understanding Arbitrary Waveform Generator Triggers	4-8
Trigger Types	4-8
Trigger Sources	4-9
Retrigger Mode	4-9
Understanding Baseband Clipping	4-10
How Power Peaks Develop	4-10
How Peaks Cause Spectral Regrowth	4-12
How Clipping Reduces Peak-to-Average Power	4-13
FIR Filtering Options (Option UN5 Only)	4-15

5. Remote Programming

Bluetooth SCPI Command Reference	5-2
Setting the Active Member Address	5-2
Setting the Device Address	5-2
Burst Off On	5-2
Setting Clock/Gate Delay	5-2
Selecting the Payload Data	5-3
Setting Frequency Drift	5-3
Setting Frequency Offset	5-3
Setting the Modulation Index	5-4
Impairments	5-4
Selecting a Packet	5-6
Setting the Burst Power Ramp	5-6
Turning On Bluetooth	5-6
CDMA Subsystem SCPI Command Reference (Options UND and UN5 Required)	5-7
ARB Reference Internal External	5-7
CDMA State	5-7
Channel Setup	5-8
Chip Rate	5-9
Clipping Level, $ I+jQ $	5-10
Clipping Level, $ I $	5-10
Clipping Level, $ Q $	5-10
Clipping, Pre/Post FIR Filter	5-10
Clipping, Type	5-10
Custom CDMA State, Store	5-11
Custom Multicarrier, Store	5-11
External Delay State	5-12
External Delay Time	5-12
External Polarity	5-12
Filter Alpha, Nyquist, or Root Nyquist	5-12
Filter BbT, Gaussian	5-13
Filter Selection	5-13

Contents

Filter Optimization	5-14
Gate Active	5-14
Multicarrier Define	5-14
Multicarrier Setup Select	5-15
Oversample Ratio	5-15
Reconstruction Filter	5-15
Reference Frequency	5-16
Retrigger Mode State	5-16
Setup Select	5-16
Trigger Source	5-17
Trigger Type	5-17
User FIR Definition	5-17
Waveform Length	5-17
Digital Modulation Subsystem SCPI Command Reference	5-18
Define User FIR	5-18
Digital Modulation Setup	5-18
Digital Modulation State	5-18
External Delay State	5-19
External Delay Time	5-19
External Polarity	5-19
Filter Alpha, Nyquist, or Root Nyquist	5-19
Filter BbT, Gaussian	5-20
Filter Optimization	5-20
Filter Selection	5-20
FSK Frequency Deviation	5-21
Gate Active Polarity	5-21
Modulation Type	5-21
Multicarrier Setup	5-22
Multicarrier Setup: Number of Carriers	5-23
Multicarrier Setup: Loading User File	5-23
Multicarrier Table Setup	5-23
Retrigger Mode State	5-24
Store Custom Modulation File	5-24
Store Multicarrier File	5-24
Symbol Rate	5-24
Trigger Source	5-25
Trigger Type	5-25
Dual ARB Subsystem SCPI Command Reference (Option UND Only)	5-26
ARB State	5-26
ARB Reference Internal External	5-26
Clipping	5-26
Create Waveform Sequence	5-27
External Delay State	5-27
External Delay Time	5-27
External Polarity	5-27
Gate Active	5-28
Markers	5-28
Reconstruction Filter	5-30
Reference Frequency	5-30

Contents

Retrigger Mode State	5-31
Sample Clock	5-31
Scaling	5-31
Select Waveform	5-31
Trigger Source	5-31
Trigger Type	5-32
Multitone Waveforms	5-33
Creating a Multitone Waveform	5-33
Turning a Multitone Waveform On and Off	5-35
Storing a Multitone Waveform	5-35
Retrieving a Stored Multitone Waveform	5-35

6. Programming Command Cross-Reference

AWGN Softkeys	6-2
Bluetooth Softkeys	6-3
CDMA Formats > IS-95A Softkeys	6-5
Dual ARB Softkeys	6-10
Multitone Softkeys	6-14
Other Formats Softkeys	6-15

1 The Dual Arbitrary Waveform Generator

This guide provides information specific to the Dual Arbitrary Waveform Generator (Option UND), and the multichannel, multicarrier CDMA personality (Option UN5) available with this option. Option UND can be used alone, but Option UN5 requires the installation of Option UND.

Overviews

This section contains the following overviews:

- “Dual Arbitrary Waveform Generator (Option UND)”
- “Multichannel, Multicarrier CDMA Personality (Option UN5)” on page 1-4

Specifications

Option specifications are included in the technical specifications document.

Dual Arbitrary Waveform Generator (Option UND)

Option UND enables you to drive the signal generator’s internal I/Q modulator to create vector-modulated signals. The Dual Arbitrary Waveform Generator uses 14-bit DACs for superior fidelity, as well as sample rates ranging from 1 Hz to 40 MHz, and 1 Megasample memory per channel.

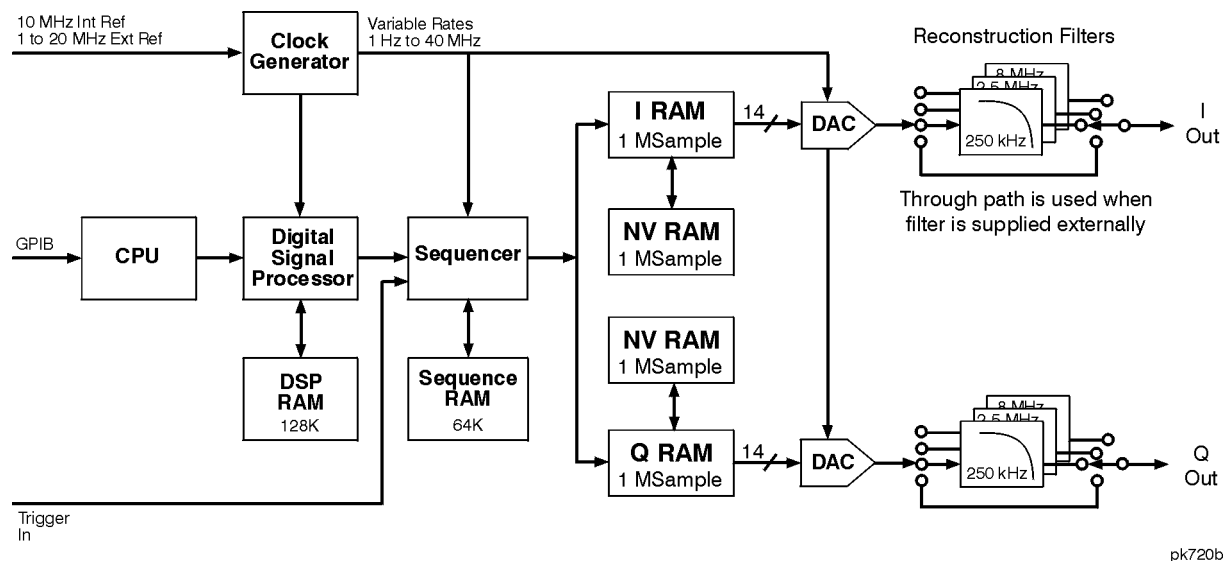

The Dual Arbitrary Waveform Generator has a digital signal processor capable of simulating optional digital communication formats, such as the “Multichannel, Multicarrier CDMA Personality (Option UN5)” described on page 1-4.

Alternately, you can use an external simulation (such as Omnisys) to generate the I/Q waveforms, download them into the I RAM and Q RAM, and sequence them for “playback.”

Using simple table editors, you can save different waveforms as separate segments, and subsequently sequence them to create a chain of repeating waveform types. You can store this information to the signal generator’s internal memory and recall it as needed.

Option UND also includes the following:

- **Waveform triggering.** Trigger types include continuous, single, gated, and (while using waveform sequences) segment advance. The retrigger mode is adjustable, as well as the gate active trigger polarity for gated triggers. The trigger source can be set to the signal generator's front panel trigger hardkey, the GPIB interface, or an external trigger signal supplied to the rear panel PATTERN TRIG IN connector. External triggers include adjustable polarity, delay, and delay time.
- **Waveform utilities:**
 - Markers,** the signal generator has two markers, that you can place on a waveform segment. Markers provide auxiliary output signals that are synchronized with a waveform segment. You can construct these output signals as a trigger signal to synchronize another instrument to a given portion of a waveform.
 - Scaling** to change the peak-to-peak output value of a waveform segment to a desired percentage of its full-scale value.
 - Baseband clipping** to limit peaks in a waveform segment by clipping the envelope to a desired percentage of the highest peak. You can clip the composite I/Q waveform or I and Q separately.
- **Additive White Gaussian Noise.** AWGN can be used to create noise signals with adjustable bandwidth, waveform length and noise seed (fixed or random).
- **Multitone waveforms.** You can generate multitone waveforms with adjustable frequency spacing, frequency offset, power, phase, and tone on/off state.
- **The Bluetooth waveform.** You can generate packets (DH1) and impairments (adjustable frequency offset, frequency drift, modulation index, and AWGN).
- **Other Formats.** You can generate single carrier or multicarrier waveforms consisting of preconfigured or custom digital modulation formats:
 - Triggering** types include, single, continuous, or gated waveform triggering, including retrigger mode.
 - Multicarrier** waveforms with an adjustable number of carriers, frequency offset, and power.
 - Custom** single carrier waveforms with configurable digital modulation type, filter, and symbol rate.

Multichannel, Multicarrier CDMA Personality (Option UN5)

Option UN5 provides multichannel, multicarrier IS-95 CDMA personality for amplifier characterization. This option requires Option UND.

Multichannel CDMA signal generation is simplified by the inclusion of 9-, 32-, and 64-channel pre-defined waveforms, offering precise signal statistics while optimizing measurement accuracy.

Multicarrier CDMA signal generation is simplified by the inclusion of 3- and 4-carrier pre-defined waveforms, offering precise signal statistics while optimizing measurement accuracy.

CDMA Physical Layer

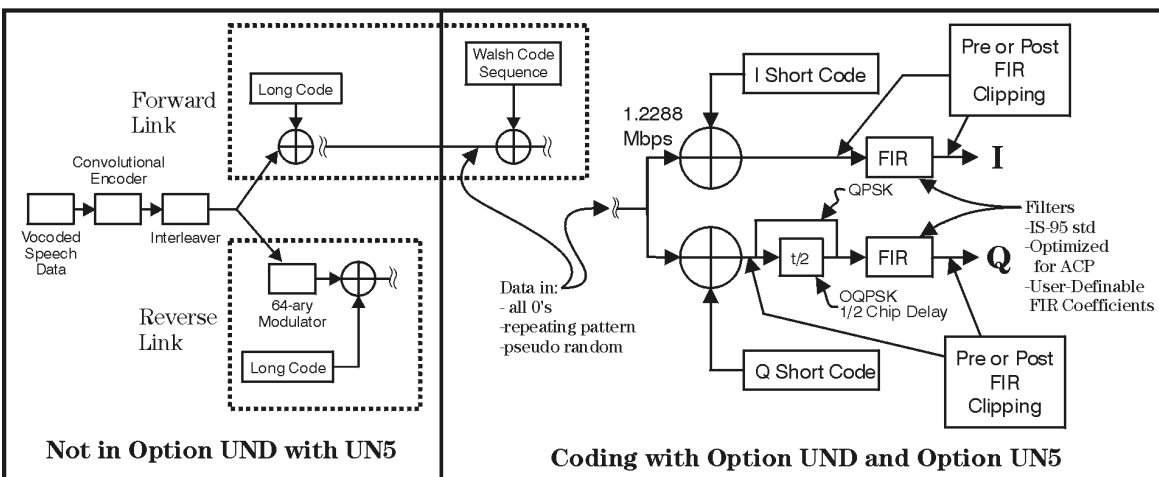

pk755b

Mobile component test is simplified using pre-defined Pilot and Reverse channel signals, and the ability to generate multiple pilot channels (Walsh 0, different PN offset) at equal or differing power levels. You can also generate a single reverse channel for mobile amplifier testing.

Option UN5 also allows for custom, user-defined multichannel and multicarrier CDMA signals. The multichannel capabilities include the simulation of fully loaded cells by generating up to 256 Walsh-coded channels, as well as the ability to define power, PN offset, and data for each Walsh-coded channel. Multicarrier capabilities include the ability to generate multicarrier CDMA setups employing up to twelve carriers with individually defined multichannel configurations, frequency offsets, and power levels. Option UN5 also includes the ability to download or enter user-defined FIR filter coefficients.

Waveform triggering is included with Option UN5. Trigger types include continuous, single, and gated. The retrigger mode is adjustable, as well as the gate active trigger polarity for gated triggers. The trigger source can be set to the signal generator's front panel trigger hardkey, the GPIB interface, or an external trigger signal supplied to the rear panel PATTERN TRIG IN connector. External triggers include adjustable polarity, delay, and delay time.

The baseband clipping capability allows you to clip the composite I/Q waveform or I and Q separately. You can also choose either pre- or post-FIR filter clipping.

2 Using Functions

This chapter contains procedures that show you how to use some of the major functions of the dual arbitrary waveform generator (Option UND) and the multichannel, multicarrier CDMA personality (Option UN5).

Table Editor Basics

Option UND provides several table editors that enable you to:

- edit a CDMA channel setup (for details, see [page 2-4](#))
- edit a multicarrier CDMA setup (for details, see [page 2-15](#))
- create a user-defined FIR filter (for details, see [page 2-35](#))
- create multitone waveforms (for details, see [page 2-47](#))
- build and edit waveform sequences (for details, see [page 2-54](#))
- edit waveform segments (for details, see [page 2-55](#))

While each of these table editors performs a different function, they are all used in basically the same way, and most of the table editors have several editing softkeys in common.

Common Edit Functions

Edit Item	Enables you to use the front panel knob and arrow keys to edit the value of a selected entry. After highlighting the value you want to edit, press this softkey.
Insert Row	Inserts a row for data above the currently selected row.
Delete Row	Deletes the currently selected row of data.
Goto Row	Displays a new page of softkeys so that you can quickly move to the first, middle, or last row of data. This is especially helpful in a large table, or when using the filter table editor mirror function.
Restore Default Filter	Enables you to reset factory default values for a filter.
Load/Store or Load Store	Displays a new page of softkeys that enables you to load data from a stored file save data to a file, or delete a stored file.
Delete All Rows	Clears all data from a table.

CAUTION There is no “undo” command. Once you delete data from a table, you cannot retrieve it.

Creating Custom CDMA States

Using this procedure, you will create a custom, forward 33 channel CDMA signal at IS-97 power levels with a traffic channel carrying user-defined data at a Walsh code of 45.

The signal generator provides a quick and easy solution to creating custom CDMA states. Rather than building the entire 33 channel set up from scratch, you will start with a forward 32 channel CDMA template and modify the template by adding one channel and changing some of the template's default values. (Options UND and UN5 are both required.)

Setting up a CDMA Template

The first step in creating a customized CDMA state is setting up a template that can be modified to fill your requirements. Follow these steps to set up a forward 32 channel CDMA template:

1. Preset the signal generator to normal preset conditions.
2. Press the front panel **Mode** key.
3. If you have multiple options and the **Arb Waveform Generator** softkey is visible, press it next.
4. Press **CDMA Formats > IS-95A > Setup Select**. The default CDMA template is set to **9 Ch Fwd**. Press **32 Ch Fwd**. This sets up a template containing 32 forward CDMA channels.

Modifying a CDMA Template

Follow these steps to modify the standard forward 32 channel CDMA template that was loaded in the previous steps. You will be inserting a traffic channel, modifying the new channel's Walsh code to 45, changing the random data to user-defined data, and adjusting the overall code domain power to IS-97 levels.

1. Press **CDMA Define > Edit Channel Setup**. This opens the table editor used to modify a CDMA channel setup. The following figure shows the 32 channel CDMA template in the CDMA Channel Setup table editor.

FREQUENCY		4.000 000 000 00 GHz		AMPLITUDE		-135.00 dBm		Edit Item
L				RF OFF		MOD ON		Insert Row▶
								Delete Row
CDMA Channel Setup				Total Power: 0.00dB				
	Type	Walsh	Power	PN	Offset	Data		Adjust. Code Domain Power▶
1	Pilot	0	-7.00 dB	0	0	00000000		
2	Paging	1	-12.95 dB	0	0	RANDOM		
3	Traffic	8	-15.95 dB	0	0	RANDOM		Display Code Domain Power▶
4	Traffic	9	-15.95 dB	0	0	RANDOM		
5	Traffic	10	-15.95 dB	0	0	RANDOM		
6	Traffic	11	-15.95 dB	0	0	RANDOM		
7	Traffic	12	-15.95 dB	0	0	RANDOM		
8	Traffic	13	-15.95 dB	0	0	RANDOM		Goto Row▶
9	Traffic	14	-15.95 dB	0	0	RANDOM		
10	Traffic	15	-15.95 dB	0	0	RANDOM		More (1 of 2)

2. As shown in the previous figure, row 8 is a Traffic channel. Select row 8 by pressing the front panel down arrow key until Traffic is highlighted. You are now ready to insert a new Traffic channel on table row 8.

Adding a New Channel Type

1. Press **Insert Row**. You are now offered the choice between Pilot, Sync, Paging, and Traffic channels.
2. Press **Traffic**. You now have a new traffic channel inserted on table row 8, at Walsh code 38, at a power level of -15.95 dB with a 0 PN offset, transmitting random data. The channel that formally occupied table row 8 has moved (along with the cursor) to table row 9 (and the channel formerly occupying table row 9 has moved to table row 10, and so on, down to table row 33). The total number of channels is now 33. Your display will look like this:

FREQUENCY		4.000 000 000 00 GHz		AMPLITUDE		-135.00 dBm		Pilot
I				RF OFF		MOD ON		Sync
CDMA Channel Setup				Total Power: 0.11dB				Paging
	Type	Walsh	Power	PN Offset	Data			Traffic
1	Pilot	0	-7.00 dB	0	00000000			
2	Paging	1	-12.95 dB	0	RANDOM			
3	Traffic	8	-15.95 dB	0	RANDOM			
4	Traffic	9	-15.95 dB	0	RANDOM			
5	Traffic	10	-15.95 dB	0	RANDOM			
6	Traffic	11	-15.95 dB	0	RANDOM			
7	Traffic	12	-15.95 dB	0	RANDOM			
8	Traffic	38	-15.95 dB	0	RANDOM			
9	Traffic	13	-15.95 dB	0	RANDOM			
10	Traffic	14	-15.95 dB	0	RANDOM			

3. Press the **Return** hardkey.

Modifying the Walsh Code

1. Use the front panel knob or the arrow keys to highlight the Walsh code value (38) on table row 8.
2. Press **Edit Item**. Walsh Code: 38 appears in the active entry area of the display.
3. Using the numeric keypad, press **45** and terminate the entry with the **Enter** softkey. The Walsh code for the channel on table row 8 has now been set to 45.

Modifying the Data

1. Use the front panel knob or arrow keys to highlight the Data value (RANDOM) on table row 8.
2. Press **Edit Item**. Data: RANDOM appears in the active entry area of the display.
3. Using the front panel knob, the up- and down-arrow keys, or the numeric keypad enter **00001000** and press the **Enter** softkey to terminate the entry. The data value on table row 8 has now been changed from RANDOM to 00001000.

Modifying the Code Domain Power

You will now adjust the overall code domain power of the custom CDMA state's channels to conform to IS-97 levels.

1. Press **Adjust Code Domain Power**.
2. Press **IS-97 Levels**. The signal generator's firmware calculates the power levels of all 33 channels and adjusts them to conform to IS-97 power levels, as shown in the figure below.

FREQUENCY		4.000 000 000 00 GHz		AMPLITUDE		-135.00 dBm		Edit Item
RF		OFF		MOD		ON		Insert Row
CDMA Channel Setup								Delete Row
						Total Power: 0.00dB		Adjust Code Domain Power
	Type	Walsh	Power	PH Offset	Data	Display Code Domain Power		
1	Pilot	0	-7.00 dB	0	00000000	Goto Row		
2	Paging	1	-13.09 dB	0	RANDOM	More (1 of 2)		
3	Traffic	8	-16.09 dB	0	RANDOM			
4	Traffic	9	-16.09 dB	0	RANDOM			
5	Traffic	10	-16.09 dB	0	RANDOM			
6	Traffic	11	-16.09 dB	0	RANDOM			
7	Traffic	12	-16.09 dB	0	RANDOM			
8	Traffic	45	-16.09 dB	0	00001000			
9	Traffic	13	-16.09 dB	0	RANDOM			
10	Traffic	14	-16.09 dB	0	RANDOM			

You now have a custom, forward 33 channel CDMA signal at IS-97 power levels, with a traffic channel carrying user-defined data at a Walsh code of 45 on table row 8. The next section provides instructions about how to apply the modified channel setup and activate the new CDMA state.

Applying a Custom Channel Setup, then Activating the Custom CDMA State and Applying it to the RF Output

This example uses the custom, forward 33 channel CDMA state created in “Creating Custom CDMA States” on page 2-3. (Options UND and UN5 are both required.)

1. Press the **Return** hardkey to return to the previous menu, then press **Apply Channel Setup** to update the waveform to the CDMA state created in the previous steps. The display changes to **CDMA Setup: 32 Ch Fwd (Modified)**. Press **Return**.
2. Press **CDMA Off On** until **On** is highlighted. Note that the **CDMA** and **I/Q** annunciators turn on. After waveform generation, the new waveform is stored in volatile memory, and is ready for application to the RF output.

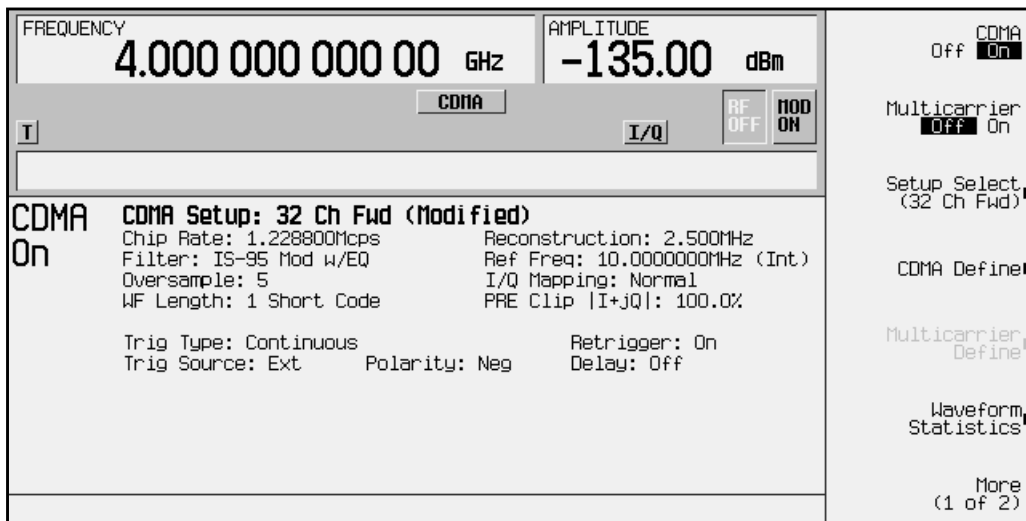

3. Set the signal generator’s RF output frequency to 890.01 MHz, and the RF output power to -10 dBm. If Mod On/Off is off, turn it on (the **MOD ON** annunciator appears on the display).
4. To activate the RF output, press **RF On/Off** to **On**. The **RF ON** annunciator appears on the signal generator’s display. See the following figure.

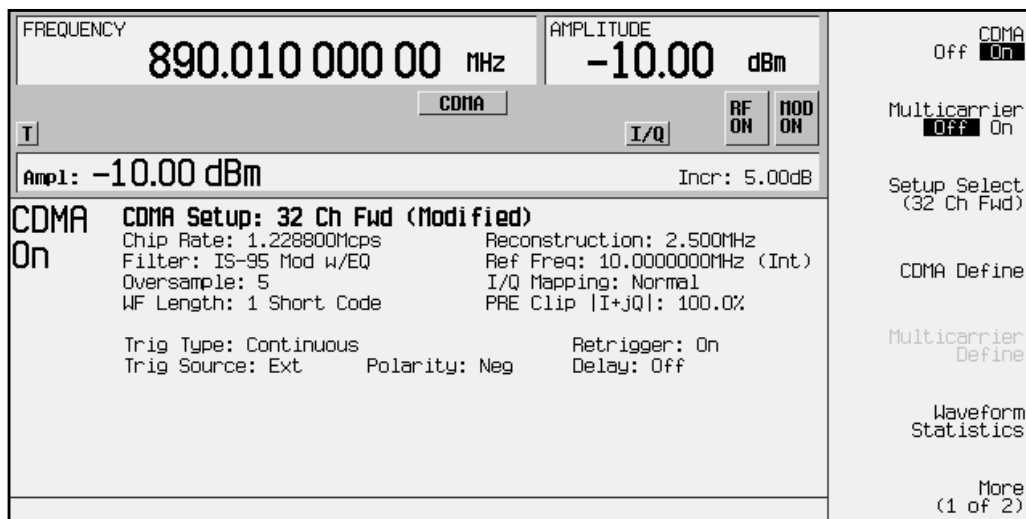

Clipping a CDMA Waveform

This example uses the custom, forward 33 channel CDMA state created in “[Creating Custom CDMA States](#)” on page 2-3. (Options UND and UN5 are both required.)

After you turn on and apply a CDMA state (see the previous section), use the following procedure to configure and apply clipping to the CDMA waveform.

1. Notice that in the status area of the display the current clipping setup is PRE Clip $|I+jQ|$: 100.0%. A clipping level of 100 percent is equal to no clipping.
2. Press **CDMA Define > More (1 of 2) > Clipping** to access the clipping setup menu.
3. Notice that the **Clipping Type $|I+jQ|$ $|I|,|Q|$** softkey default is $|I+jQ|$ (*circular clipping*). This selection clips the combined I and Q waveform. Alternatively, $|I|,|Q|$ (*rectangular clipping*) clips the I and Q waveforms separately. Use the default selection for this example.
4. Press **Clip $|I+jQ|$ To** and enter 80 percent.
5. Notice that the **Clip At PRE POST FIR Filter** softkey default is **PRE**. With **PRE** selected, the waveform is clipped prior to FIR filtering. Alternatively, when you select **POST**, the waveform is clipped after FIR filtering. Use the default selection for this example.
6. Press **Apply to Waveform**. The signal generator rebuilds the waveform and the clipping settings are updated in the status area of the display, as shown. For more information on clipping, refer to “[Understanding Baseband Clipping](#)” on page 4-10.

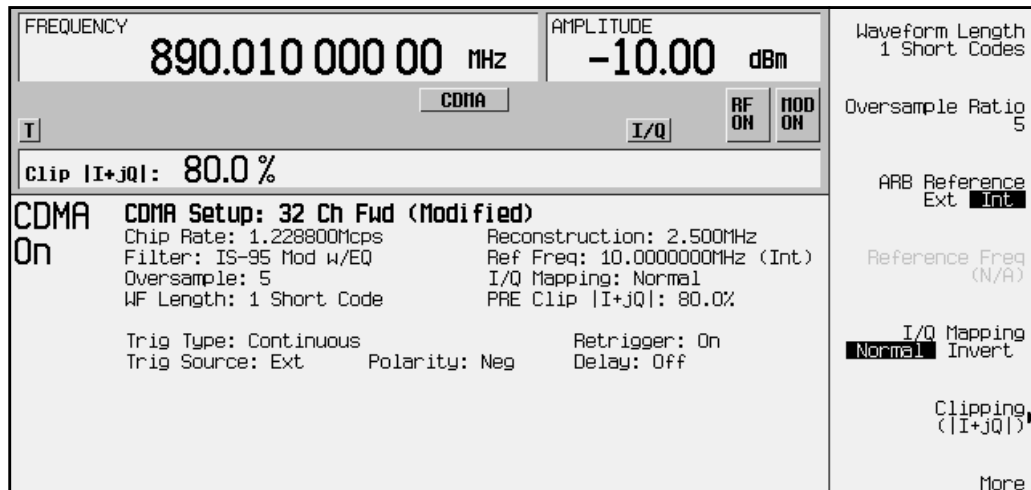

Viewing Code Domain Power and Waveform Statistics

The signal generator can display a graphical representation of code domain power and Complementary Cumulative Distribution Function. To view this representation, press **Mode > ARB Waveform Generator (if it appears) > CDMA Formats > IS-95A > CDMA Define > Edit Channel Setup > Display Code Domain Power**. The following figure depicts your customized CDMA waveform's code domain power.

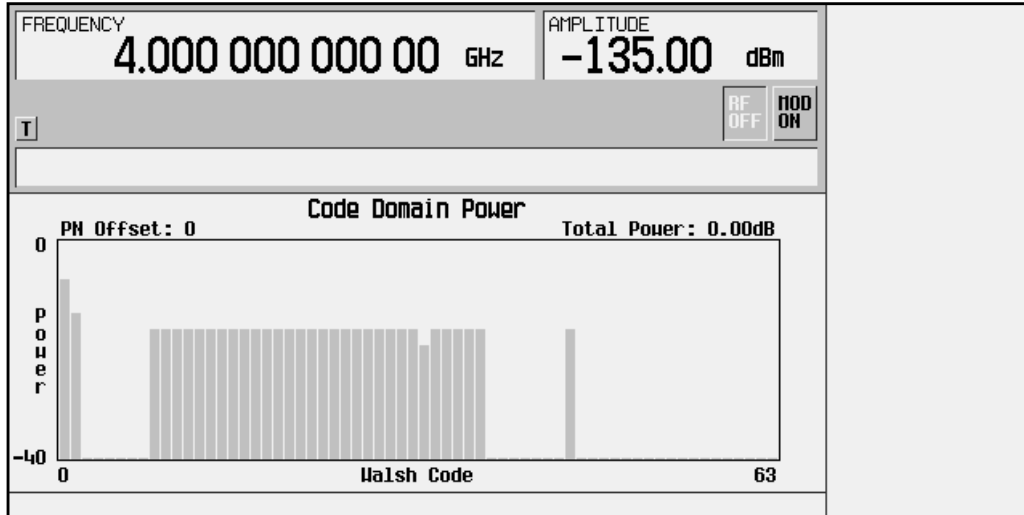

Code domain power is displayed as a graph depicting power (in decibels) on the y-axis and Walsh Code on the x-axis. PN offset is also displayed along with total code domain power.

If there is channel data assigned to more than one PN offset, pressing the **Display Code Domain Power** softkey will open a menu where you can select **Previous PN Offset** or **Next PN Offset**.

The following is an example of the Code Domain Power graph display with the additional softkeys.



After viewing the code domain power, press **Return** 3 times to return to the top-level CDMA menu where **CDMA Off On** is the first softkey.

Complementary Cumulative Distribution Function is a representation of the probable occurrence of power peaks compared to average power. To view the Complementary Cumulative Distribution Function for your CDMA waveform, press **Waveform Statistics > Plot CCDF**. The following figure depicts the Complementary Cumulative Distribution function for your CDMA waveform.

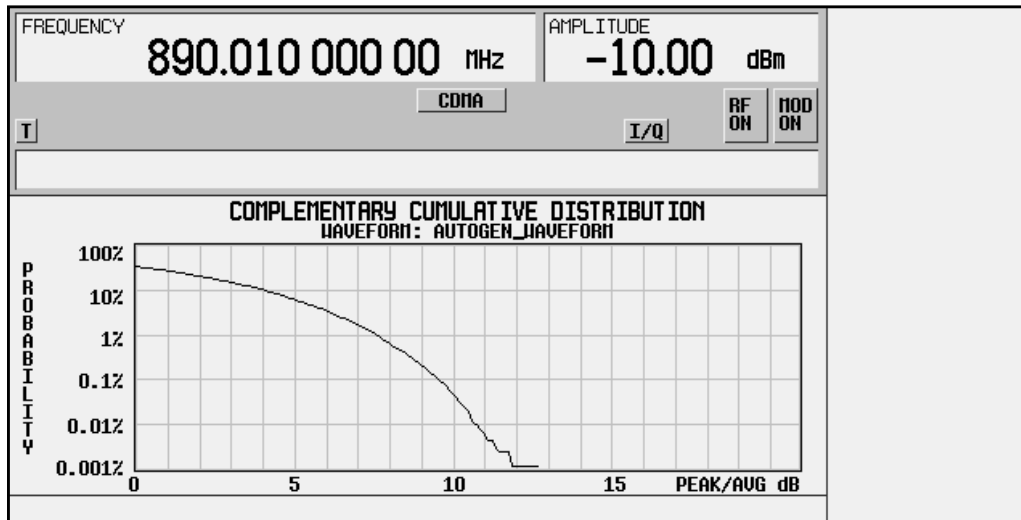

Storing a Custom CDMA State to Memory

Using this procedure, you will learn how to store a custom CDMA state to the signal generator's memory catalog. For this example, use the custom, forward 33 channel CDMA state you created in the previous procedure. If you have not created this custom CDMA state, refer to the previous section, "Creating Custom CDMA States." (Options UND and UN5 are both required.)

1. In the top-level CDMA menu, press **CDMA Define**.
2. Press **Store Custom CDMA State**. This softkey displays the signal generator's catalog of CDMA files.
3. Press **Store To File** to open a menu of letters and symbols that you can use to name the file.

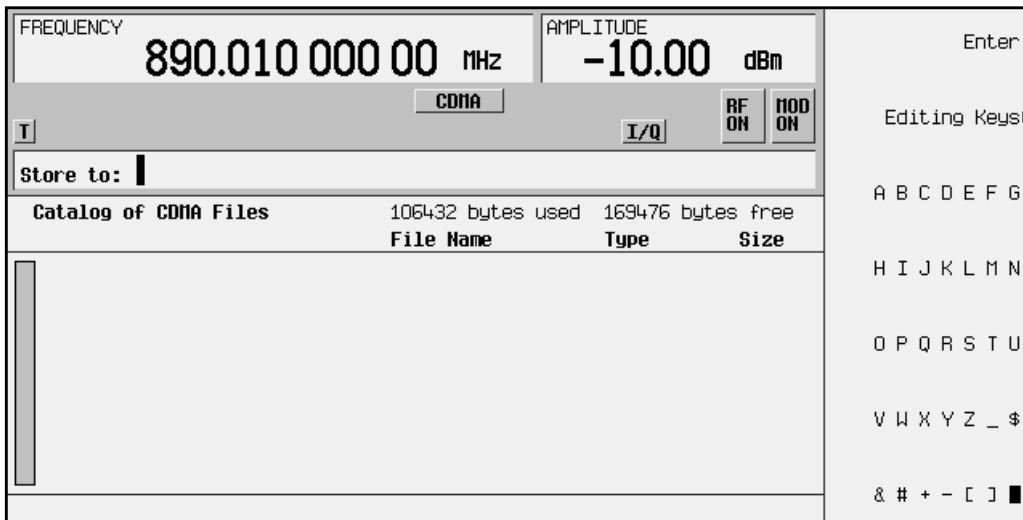

- Name this file 33CHFWD97 (33 channel forward at IS-97 levels). If there is already a file highlighted in the CDMA catalog, press **Edit Keys > Clear Text**. Press: **3 > 3 > ABCDEFG > C > HIJKLM > H > ABCDEF > F > VWXYZ_\$ > W > ABCDEFG > D > 9 > 7** and terminate the entry by pressing **Enter**. You now have a file called 33CHFWD97 stored in the signal generator's volatile ARB memory, as shown in the following figure.

FREQUENCY		890.010 000 00 MHz		AMPLITUDE		-10.00 dBm		Store To File	
		CDMA		RF ON		MOD ON			
I		I/Q							
Catalog of CDMA Files		106880 bytes used		169028 bytes free				Delete File	
		File Name		Type		Size			
1		33CHFWD97		CDMA		390		Goto Row▶	
								Page Up	
								Page Down	

Recalling Custom CDMA States

Using this procedure, you will recall a custom CDMA state from the signal generator's memory. For this example, use the custom, forward 33 channel CDMA state created in the procedure titled, "Creating Custom CDMA States" and stored using the procedure titled, "Storing Custom CDMA States." If you have not created and stored a custom CDMA state, refer to these previous sections. (Options UND and UN5 are both required.)

1. Preset the signal generator to normal preset conditions.
2. Press the front panel **Mode** key.
3. If you have multiple options and the **Arb Waveform Generator** softkey is visible, press it next.
4. Press **CDMA Formats > IS-95A > Setup Select**. The default CDMA template is set to **9 Ch Fwd**. Press **Custom CDMA State**. This opens a catalog of custom CDMA states, as shown in the following figure.

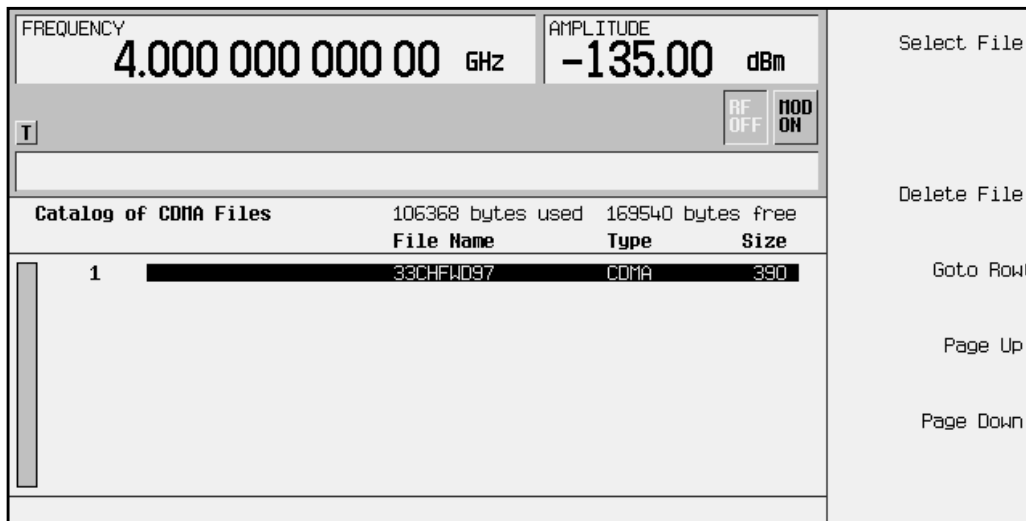

5. Use the front panel knob or the arrow keys to highlight the file **33CHFWD97**, then press **Select File**. The custom CDMA state **33CHFWD97** is selected.

- To activate the recalled custom CDMA state, press **CDMA Off On** to **On**. The firmware generates the custom CDMA waveform in ARB memory. After waveform generation, the custom CDMA state is available to be modulated on the RF output. See the following figure.

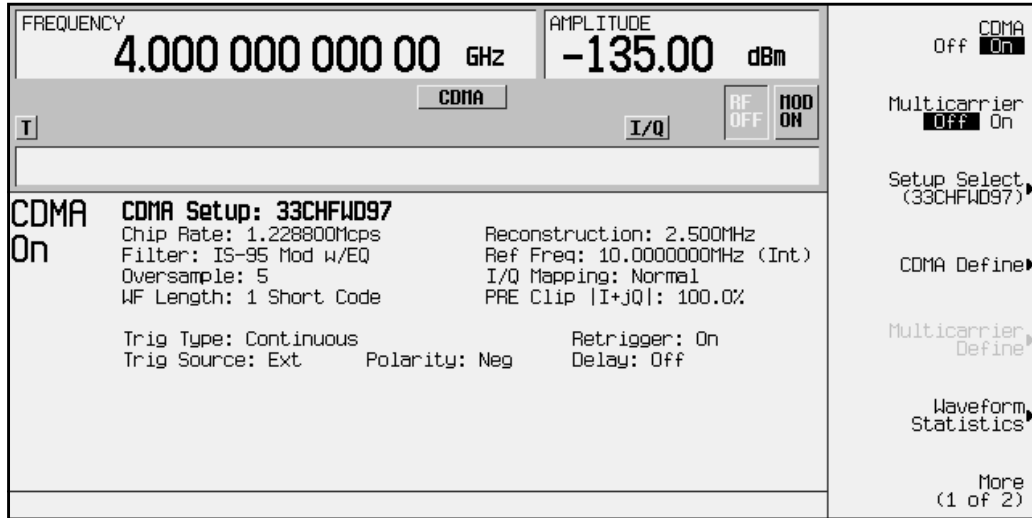

- At signal generator preset, **Mod On/Off** is set to **On**. If you did not start this procedure by presetting the signal generator, press **Mod On/Off** to **On**.

NOTE The RF output amplitude and frequency settings are not saved as part of a custom CDMA state file. At signal generator preset (or line power cycle), the RF output frequency is reset to the signal generator's highest specified value and the RF output amplitude is reset to -135 dBm. Before activating the RF output, make adjustments to the RF output frequency and amplitude as required.

- To activate the RF output, press **RF On/Off** to **On**.

Creating Custom Multicarrier CDMA Waveforms

Using this procedure, you will create a custom 5-carrier CDMA waveform.

The signal generator provides a quick and easy solution to creating custom multicarrier CDMA waveforms. Rather than building the entire 5-carrier setup from scratch, you will start with a 3-carrier CDMA template and modify the template by adding two additional carriers and changing some of the template's default values. (Options UND and UN5 are both required.)

Opening the Multicarrier CDMA Setup Table Editor

1. Preset the signal generator.

Press **Preset** to return the signal generator to normal preset conditions.

2. Activate the multicarrier CDMA mode.

Press the front panel **Mode** key. (If you have multiple options and the **Arb Waveform Generator** softkey is visible, press it next.) Press **CDMA Formats > IS-95A > Multicarrier Off On** until **On** is highlighted.

3. Open the Multicarrier CDMA Setup table editor.

Press **Multicarrier Define**. This opens the Multicarrier CDMA Setup table editor. The 3-carrier CDMA template is automatically placed in the table editor when the table editor is opened.

Understanding the Multicarrier CDMA Setup Table Editor

You can use the Multicarrier CDMA Setup table editor to create multicarrier CDMA waveforms containing up to 12 carriers. Along with the arrow keys and the front panel knob, the Multicarrier CDMA Setup softkeys are used to move throughout the table entries, edit the values, insert/delete table rows, and to apply and store the custom multicarrier CDMA setup.

The following values are definable for each individual carrier:

- Carrier Type - pilot, 9 channel forward, 32 channel forward, 64 channel forward, reverse, or custom CDMA carriers
- Frequency Offset - adjustable from -7.5 to 7.5 MHz
- Power Level - adjustable from -40.0 to 0.00 dB

Active Entry Area

Multicarrier CDMA Setup softkeys

Multicarrier CDMA Setup			
	Carrier	Freq Offset	Power
1	9 Ch Fwd	-1.250000 MHz	0.00 dB
2	9 Ch Fwd	0.000 kHz	0.00 dB
3	9 Ch Fwd	1.250000 MHz	0.00 dB
4			

Carrier Type **Frequency Offset Value** **Power Value**

RF OFF MOD ON

Edit Item
 Insert Row
 Delete Row
 Goto Row
 Store Custom Multicarrier
 Apply Multicarrier

Modifying a Multicarrier CDMA 3-Carrier Template

Use the following steps to modify the standard 3-carrier CDMA template that was loaded in the previous steps. You will be inserting one pilot carrier and another 32 channel forward carrier, and modifying the frequency offset and power values for both new carriers.

1. Add the first new carrier.

Using the front panel knob or the arrow keys, move the cursor until the second 9 channel forward carrier (in table row 2) is highlighted. Press: **Insert Row > Pilot**. This inserts a pilot carrier between the first two 9 channel forward carriers. Press **Return**. The new pilot carrier has a default frequency offset of 0.000 kHz and a default power level of 0.00 dB, as shown in the following figure.

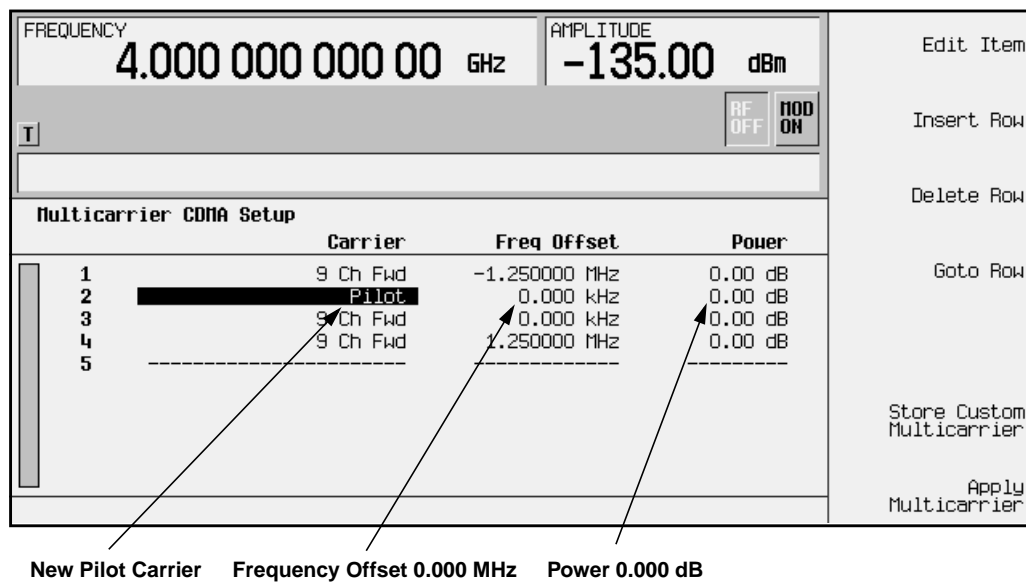

2. Modify the frequency offset value.

Highlight the new pilot carrier's frequency offset value and press **Edit Item**. Then, using the numeric keypad, enter -625 and press the **kHz** terminator. Note that after you enter the new frequency offset value, the cursor moves downward in the same column, ready to modify the next entry in the same category, as shown in the following figure.

Frequency Offset -625.000 kHz

FREQUENCY 4.000 000 000 00 GHz		AMPLITUDE -135.00 dBm		Edit Item
T		RF OFF MOD ON		Insert Row▶
Multicarrier CDMA Setup				
	Carrier	Freq Offset	Power	Delete Row
1	9 Ch Fwd	-1.250000 MHz	0.00 dB	Goto Row▶
2	Pilot	-625.000 kHz	0.00 dB	
3	9 Ch Fwd	0.000 kHz	0.00 dB	
4	9 Ch Fwd	1.250000 MHz	0.00 dB	
5	-----	-----	-----	
				Store Custom Multicarrier▶
				Apply Multicarrier

3. Modify the power level.

Highlight the pilot carrier's power value and press **Edit Item**. Then enter -10 and press the **dB** terminator. The following figure shows the modified power value.

Power -10.00 dB

FREQUENCY 4.000 000 000 00 GHz		AMPLITUDE -135.00 dBm		Edit Item
T		RF OFF MOD ON		Insert Row▶
Multicarrier CDMA Setup				
	Carrier	Freq Offset	Power	Delete Row
1	9 Ch Fwd	-1.250000 MHz	0.00 dB	Goto Row▶
2	Pilot	-625.000 kHz	-10.00 dB	
3	9 Ch Fwd	0.000 kHz	0.00 dB	
4	9 Ch Fwd	1.250000 MHz	0.00 dB	
5	-----	-----	-----	
				Store Custom Multicarrier▶
				Apply Multicarrier

4. Add the second new carrier.

Move the cursor until the third 9 channel forward carrier (table row 4) is highlighted. Press **Insert Row > 32 Ch Fwd**. This inserts a 32 channel forward carrier between the second and third 9 channel forward carriers. Press **Return**. The new 32 channel forward carrier has a default frequency offset of 1.250000 MHz and a default power level of 0.00 dB, as shown in the following figure.

The screenshot shows the 'Multicarrier CDMA Setup' screen. At the top, the frequency is 4.000 000 000 00 GHz and the amplitude is -135.00 dBm. The table below lists the carriers:

Carrier	Carrier	Freq Offset	Power
1	9 Ch Fwd	-1.250000 MHz	0.00 dB
2	Pilot	-625.000 kHz	-10.00 dB
3	9 Ch Fwd	0.000 kHz	0.00 dB
4	32 Ch Fwd	1.250000 MHz	0.00 dB
5	9 Ch Fwd	1.250000 MHz	0.00 dB
6	-----	-----	-----

Labels below the screenshot point to the '32 Ch Fwd' carrier type, the '1.250000 MHz' frequency offset, and the '0.00 dB' power level.

5. Modify the frequency offset.

Highlight the new 32 channel forward carrier's frequency offset value and press **Edit Item**. Then enter 625 and press the **kHz** terminator.

The screenshot shows the 'Multicarrier CDMA Setup' screen after modification. The frequency offset for carrier 4 is now 625.000 kHz. The table is as follows:

Carrier	Carrier	Freq Offset	Power
1	9 Ch Fwd	-1.250000 MHz	0.00 dB
2	Pilot	-625.000 kHz	-10.00 dB
3	9 Ch Fwd	0.000 kHz	0.00 dB
4	32 Ch Fwd	625.000 kHz	0.00 dB
5	9 Ch Fwd	1.250000 MHz	0.00 dB
6	-----	-----	-----

An arrow points from the label 'Frequency Offset 625.000 kHz' to the highlighted '625.000 kHz' value in the table.

6. Modify the power level.

Highlight the new 32 channel forward carrier's power value and press **Edit Item**. Then enter **-5** and press the **dB** terminator.

Power -5.00 dB

FREQUENCY		AMPLITUDE	
4.000 000 000 00 GHz		-135.00 dBm	
T		RF OFF / MOD ON	
Multicarrier CDMA Setup			
	Carrier	Freq Offset	Power
1	9 Ch Fwd	-1.250000 MHz	0.00 dB
2	Pilot	-625.000 kHz	-10.00 dB
3	9 Ch Fwd	0.000 kHz	0.00 dB
4	32 Ch Fwd	625.000 kHz	-5.00 dB
5	9 Ch Fwd	1.250000 MHz	0.00 dB
6	-----	-----	-----

Menu options on the right: Edit Item, Insert Row, Delete Row, Goto Row, Store Custom Multicarrier, Apply Multicarrier

Applying and Activating the Custom Multicarrier CDMA Setup

You now have a custom 5-carrier CDMA signal. Follow the instructions below to apply and activate the custom multicarrier CDMA setup.

1. Apply the new custom multicarrier CDMA setup.

Press **Apply Multicarrier**. (Note that it is not necessary to apply the new setup unless **CDMA Off On** is set to **On**. **Apply Multicarrier** is used to apply changes made to the multicarrier CDMA setup while CDMA is activated.) This updates the waveform to the custom multicarrier CDMA state you created and modified during the previous steps. Press **Return**. Notice that the display shows that the Multicarrier Setup has been changed from **Multicarrier Setup: 3 Carriers** to the amended **Multicarrier Setup: 3 Carriers (Modified)**.

2. Activate the new custom multicarrier CDMA setup.

Press **CDMA Off On** until **On** is highlighted. After waveform generation, the new multicarrier CDMA waveform is stored in volatile memory, and is ready for application to the RF output.

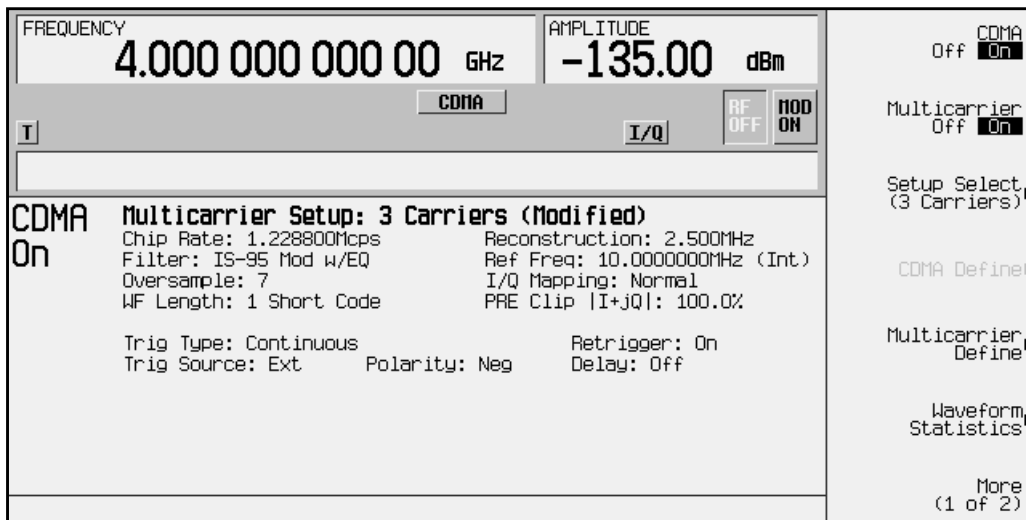

Applying the Custom Multicarrier CDMA Waveform to the RF Output

In the previous steps, you generated a custom 5-carrier CDMA waveform and stored it in volatile memory. Follow the instructions below to apply the modified multicarrier CDMA setup to the signal generator's RF output.

1. Set the signal generator's RF output frequency to 890.01 MHz.

Press **Frequency**, using the numeric keypad enter 890.01, and press the **MHz** terminator softkey.

2. Set the signal generator's RF output power to -10.0 dBm.

Press **Amplitude**, using the numeric keypad enter -10.0 , and press the **dBm** terminator softkey.

3. Activate the modulation (if necessary).

If **Mod On/Off** is set to **Off**, press **Mod On/Off** to **On**. The **MOD ON** annunciator appears on the signal generator's display. (At normal signal generator preset, the **Mod On/Off** is set to **On**.)

4. Activate the RF output.

Press **RF On/Off** to **On**. The **RF ON** annunciator appears on the signal generator's display, as shown in the following figure.

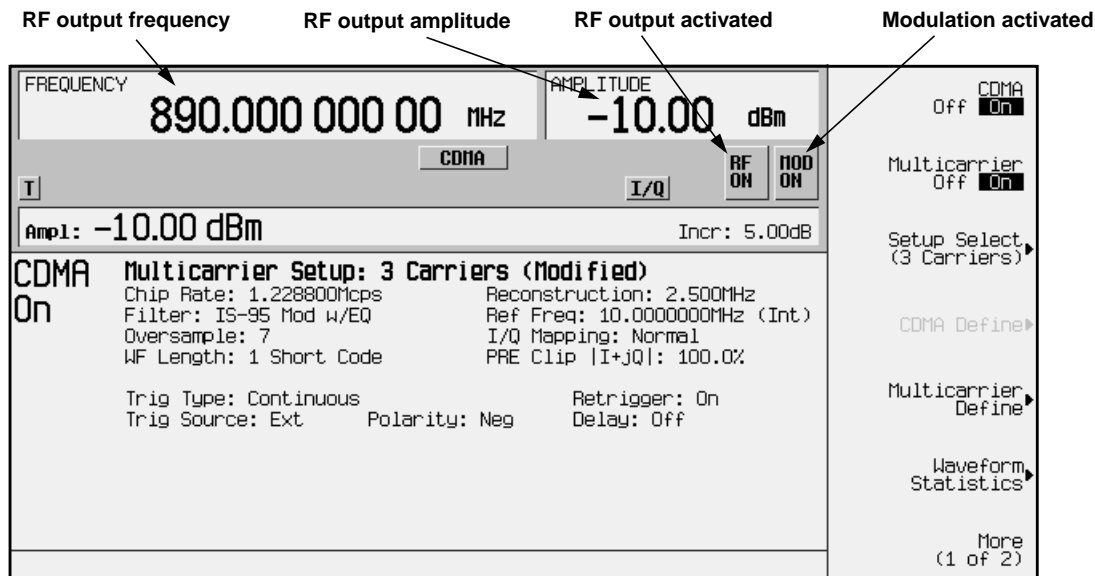

Storing a Custom Multicarrier CDMA Waveform

Using this procedure, you will learn how to store a custom multicarrier CDMA waveform to the signal generator's memory. For this example, use the custom 5-carrier CDMA waveform you created in the previous procedure. If you have not created this custom multicarrier CDMA waveform, refer to the previous section, "Creating Custom Multicarrier CDMA Waveforms" on page 2-15. (Options UND and UN5 are both required.)

1. Prepare to store the custom multicarrier CDMA waveform you created in the previous section.
In the top-level CDMA menu (CDMA Off On is the top key), press **Multicarrier Define**.
2. Open the MCDMA memory catalog.
Press **Store Custom Multicarrier**. This softkey displays the signal generator's catalog of MCDMA (multicarrier CDMA) files.
3. Open the file naming menu in the memory catalog.
Press **Store To File** to open a file naming softkey menu of letters and symbols that you can use to name the file.

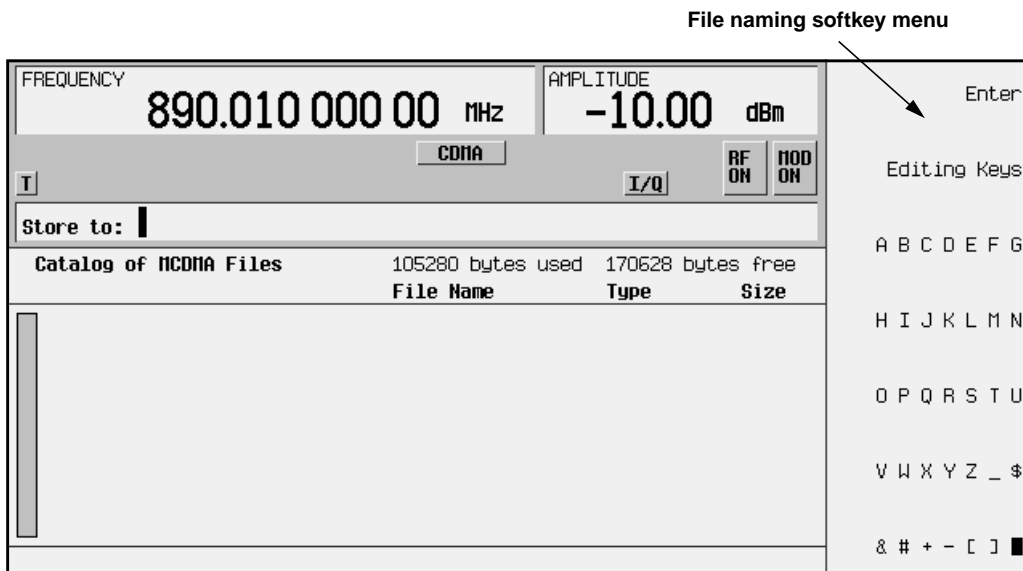

- If there is already a file highlighted in the MCDMA catalog, press **Edit Keys > Clear Text**. Using the numeric keypad and the file naming (letter and symbol) softkeys, name this file **5CARRIER** and terminate the entry by pressing **Enter**. You now have a file called **5CARRIER** stored in the signal generator's MCDMA memory, as shown in the following figure.

Custom Multicarrier CDMA file "5CARRIER" stored in MCDMA catalog

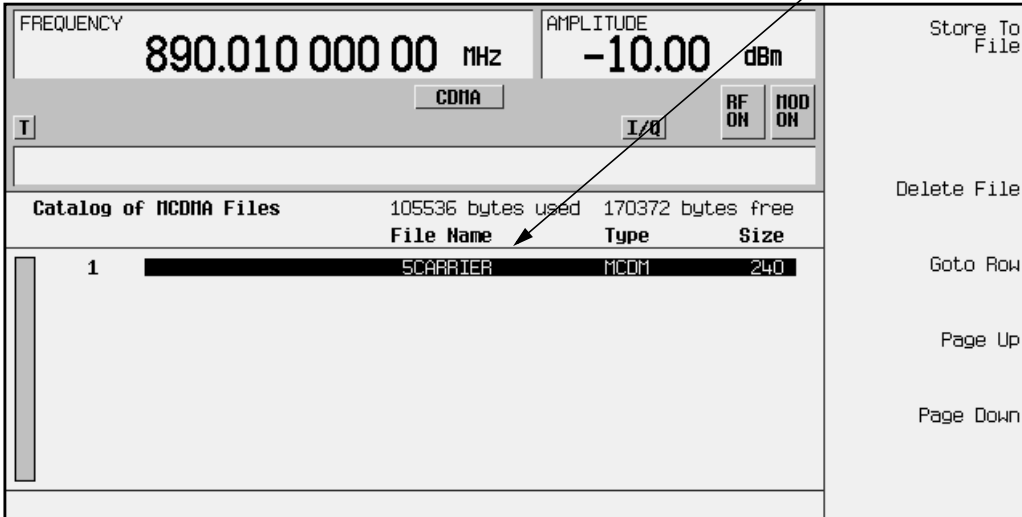

Recalling Custom Multicarrier CDMA Waveforms

Using this procedure, you will recall a custom multicarrier CDMA state from the signal generator's MCDMA memory catalog. For this example, recall 5CARRIER, the custom 5-carrier CDMA waveform created in the procedure titled, "Creating Custom Multicarrier CDMA Waveforms" on page 2-15 and stored using the procedure titled, "Storing a Custom Multicarrier CDMA Waveform" on page 2-23. If you have not created and stored a custom multicarrier CDMA waveform, refer to these previous sections. (Options UND and UN5 are both required.)

1. Preset the signal generator.

Press **Preset** to return the signal generator to normal preset conditions.

2. Activate the multicarrier CDMA mode.

Press the front panel **Mode** key. If you have multiple options and the **Arb Waveform Generator** softkey is visible, press it next. Press **CDMA Formats > IS-95A > Multicarrier Off On** until **On** is highlighted.

3. Open the multicarrier CDMA (MCDMA) memory catalog.

Press **Setup Select**. The default multicarrier CDMA template is set to **3 Carriers**. Press **Custom CDMA Multicarrier** to open the MCDMA memory catalog.

4. Choose a custom multicarrier CDMA waveform from the MCDMA memory catalog.

Use the front panel knob or the arrow keys to highlight the file 5CARRIER, then press **Select File**. The custom multicarrier CDMA waveform 5CARRIER is selected, as shown in the following figure.

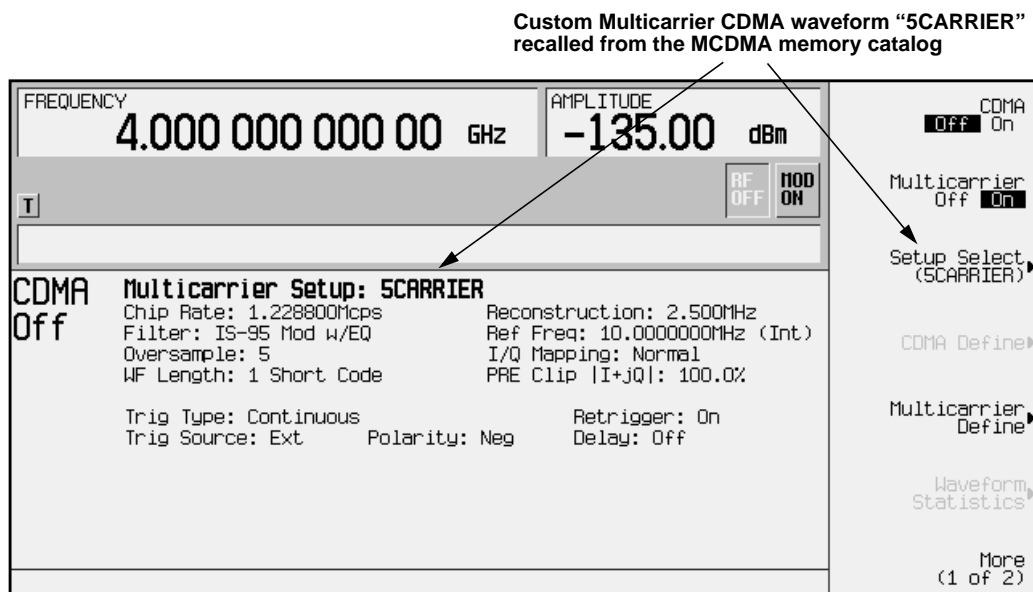

5. Activate the custom multicarrier CDMA waveform.

To activate the recalled custom multicarrier CDMA waveform, press **CDMA Off On** to **On**. The firmware generates the custom multicarrier CDMA waveform in ARB memory. After waveform generation, the custom multicarrier CDMA state is available to be modulated on the RF output.

6. Activate the modulation.

At signal generator preset, **Mod On/Off** is set to **On**. If you did not start this procedure by presetting the signal generator, press **Mod On/Off** to **On**.

NOTE The RF output amplitude and frequency settings are not saved as part of a custom multicarrier CDMA state file. At signal generator preset (or line power cycle), the RF output frequency is reset to the signal generator's highest specified value and the RF output amplitude is reset to -135 dBm. Before activating the RF output, make adjustments to the RF output frequency and amplitude as required.

7. Activate the RF output.

To activate the RF output, press **RF On/Off** to **On**.

Setting Up Predefined Single Carrier Digital Modulation

This procedure will show you how to quickly set up a predefined, single carrier, digital modulation format.

This example uses a GSM modulation format with frequency set to 1 GHz and amplitude set to -10 dBm. The predefined GSM modulation format uses the following default settings:

- Modulation type = MSK
- Filter = Gaussian
- Filter Bbt = 0.300
- Data = random
- Symbol rate = 270.833333 ksp/s

1. Preset the signal generator to normal preset conditions.
2. Change the frequency to 1 GHz and the amplitude to -10 dBm, then turn on RF.
 - To change the frequency, press **Frequency** > **1** > **GHz**.
 - To change the amplitude, press **Amplitude** > **-10** > **dBm**.
 - Toggle **RF On/Off** to on, and verify by viewing the **RF ON** annunciator on the front panel display.
3. Press the front panel **Mode** key.
4. If you have multiple options and the **Arb Waveform Generator** softkey is visible, press it next, then press **Other Formats** to access the Digital Modulation menu.
5. Make sure that **Multicarrier Off On** is toggled to **Off**.

- Press **Setup Select > GSM**. The screen returns to the Digital Modulation menu, which shows the parameters of the predefined setup in the text area of the display, as shown in the following figure.

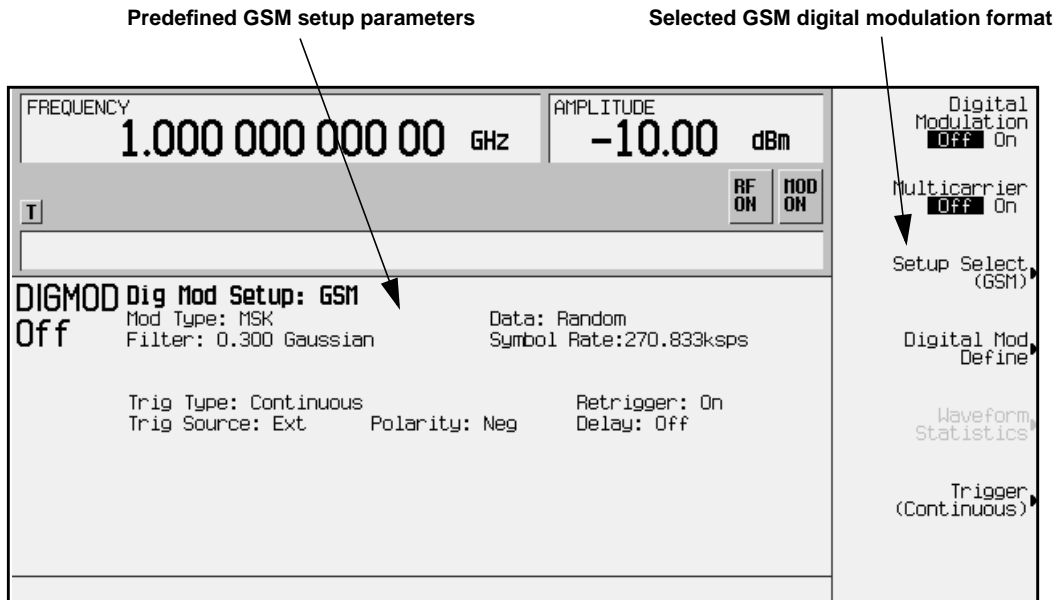

- Toggle **Digital Modulation Off On** to **On**. Notice that the **DIGMOD** and **I/Q** annunciators are enabled on the front panel display. The signal generator builds the waveform as soon as Digital Modulation is turned on, as shown in the following figure.

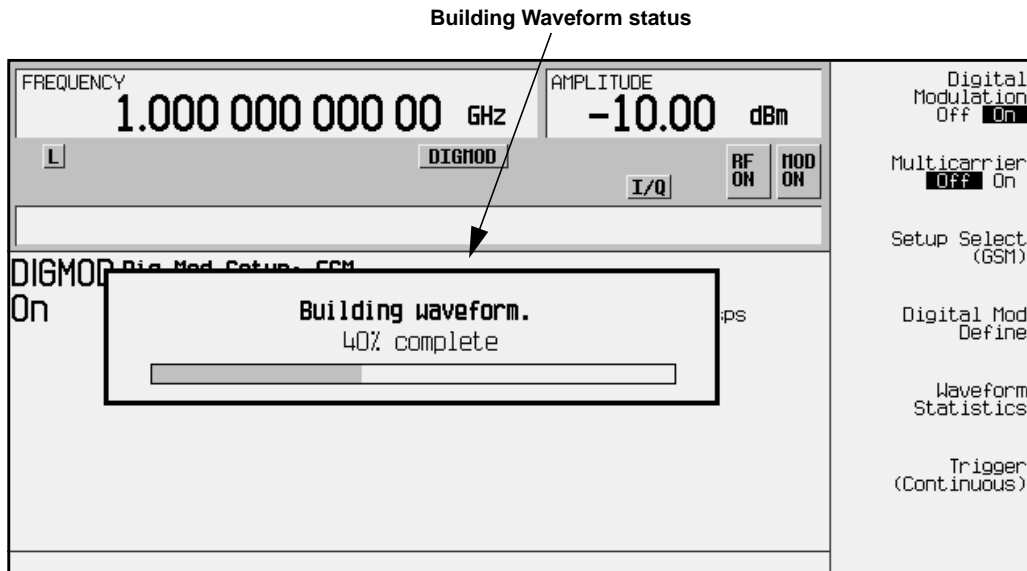

Setting Up Custom Single Carrier Digital Modulation

This procedure will show you how to quickly set up a custom, single carrier, digital modulation format.

This example uses a modified NADC modulation format with frequency set to 890 MHz and amplitude set to -10.00 dBm. This modulation format will use the following settings:

- Modulation type = QPSK
 - Filter = Nyquist
 - Filter Alpha = 0.350
 - Data = random
 - Symbol rate = 56 ksps
1. Preset the signal generator to normal preset conditions.
 2. Change the frequency to 890 MHz and the amplitude to -10 dBm, then turn on RF.
 - To change the frequency, press **Frequency > 890 > MHz**.
 - To change the amplitude, press **Amplitude > -10 > dBm**.
 - Toggle **RF On/Off** to on, and verify by viewing the **RF ON** annunciator on the front panel display.
 3. Press the front panel **Mode** key.
 4. If you have multiple options and the **Arb Waveform Generator** softkey is visible, press it next, then press **Other Formats** to access the Digital Modulation menu.
 5. Make sure that **Multicarrier Off On** is toggled to **Off**.
 6. To select NADC format, press **Setup Select > NADC**. The display returns to the Digital Modulation menu.

- To select QPSK digital modulation, press **Digital Mod Define > Modulation Type > PSK > QPSK and OQPSK > QPSK**. Notice that the status area of the display shows **Dig Mod Setup: NADC (Modified)**, and **QPSK** is displayed under the **Modulation Type** softkey, as shown in the following figure.

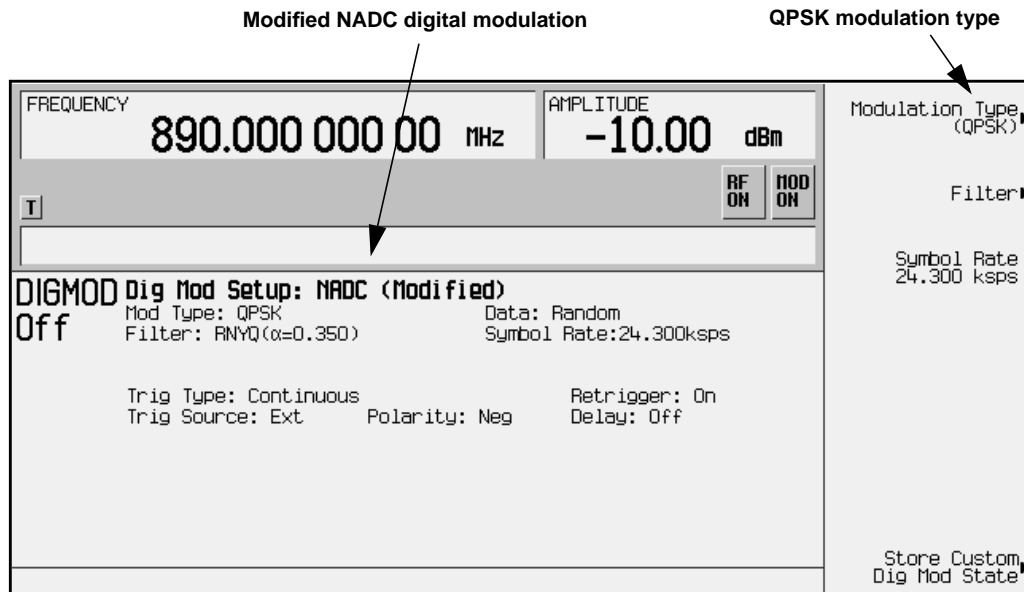

- To select a Nyquist filter, press **Filter > Select > Nyquist**. The display returns to the **Filter Select** menu.
- Press **Return** once to return to the **Digital Mod Define** menu.
- To change the symbol rate, press **Symbol Rate**, then enter **56** on the numeric keypad and press the **ksp/s** terminator. The display returns to the **Digital Mod Define** menu.

11. To store the custom configuration, press **Store Custom Dig Mod State > Store To File**. Notice the cursor is positioned after the **Store to:** field in the active entry area of the display, as shown in the following figure.

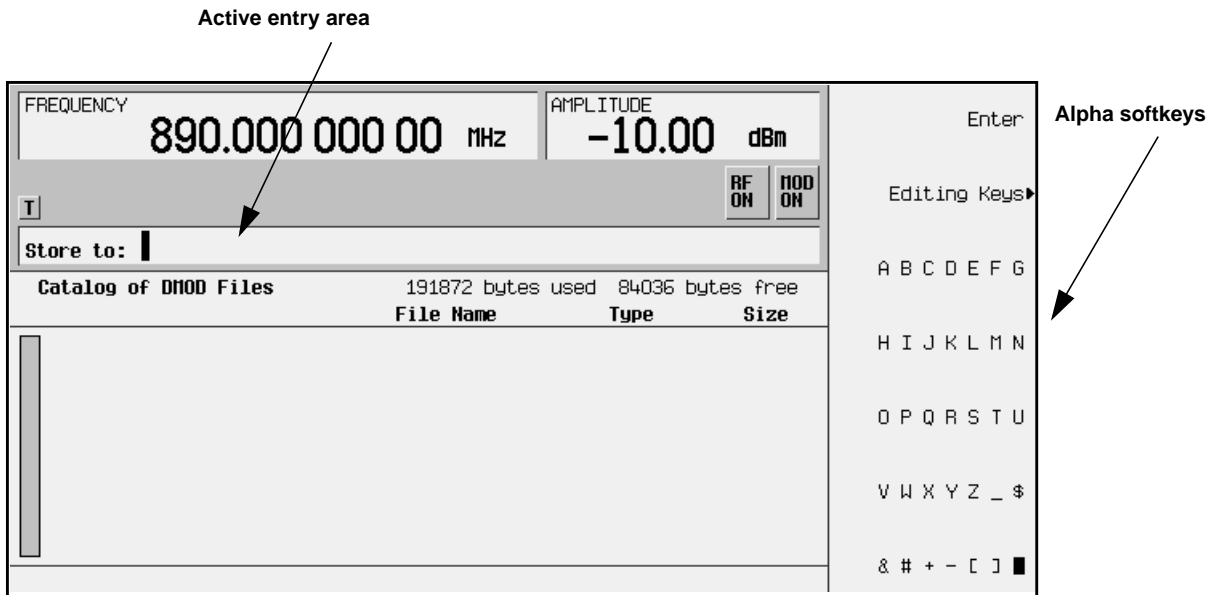

12. Use the alpha softkeys and the numeric keypad to name the file. Enter **NADC1**, then press **Enter**. Notice that the file named **NADC1** is listed in the catalog of DMOD files, as shown in the following figure.

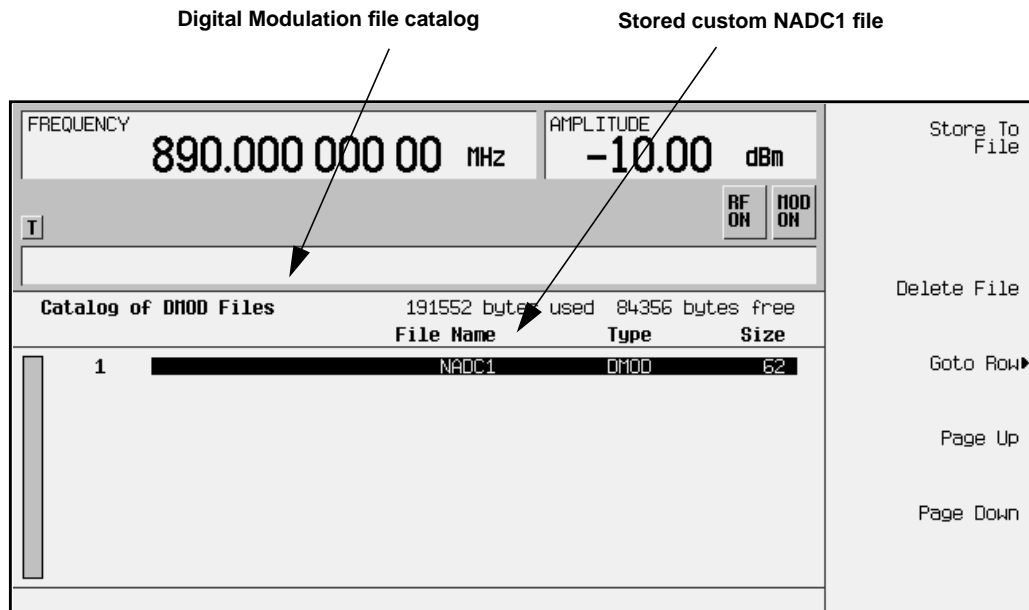

13. Press the **Return** key twice to return to the Digital Modulation menu. Notice that **NADC1** is displayed under the **Setup Select** softkey and in the **Dig Mod Setup** field in the status area of the display, as shown in the following figure.

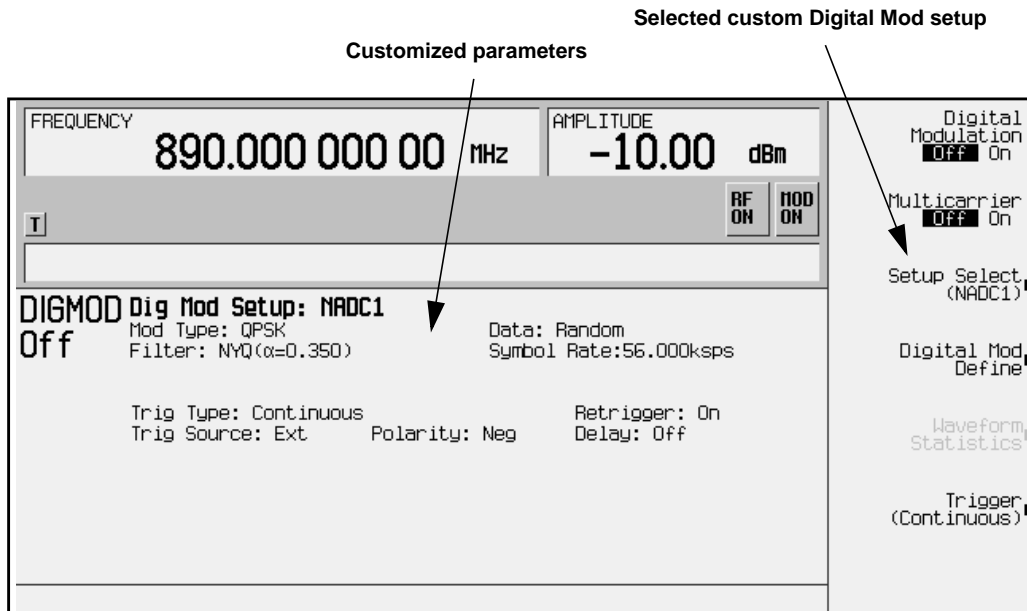

14. To turn on the custom digital modulation format and generate the waveform, toggle **Digital Modulation Off On** to **On**. Notice that the **DIGMOD** and **I/Q** annunciators are enabled on the front panel display. The signal generator builds the waveform as soon as Digital Modulation is turned on.

Setting Up a Multicarrier Digital Modulation

This procedure will show you how to quickly set up a predefined, multicarrier digital modulation format.

This example uses an NADC modulation format with eleven carriers, spaced by 100 kHz, with frequency set to 1 GHz and amplitude set to -10 dBm.

1. Preset the signal generator to normal preset conditions.
2. Change the frequency to 1 GHz and the amplitude to -10 dBm, then turn on RF.
 - To change the frequency, press **Frequency > 1 > GHz**.
 - To change the amplitude, press **Amplitude > -10 > dBm**.
 - Toggle **RF On/Off** to **On**, and verify by viewing the **RF ON** annunciator on the front panel display.
3. Press the front panel **Mode** key.
4. If you have multiple options and the **Arb Waveform Generator** softkey is visible, press it next, then press **Other Formats** to access the Digital Modulation menu.
5. Make sure that **Multicarrier Off On** is toggled to **On**.
6. Press **Multicarrier Define > Initialize Table > Carrier Setup > NADC**. The display returns to the Initialize Table menu, as shown in the following figure.

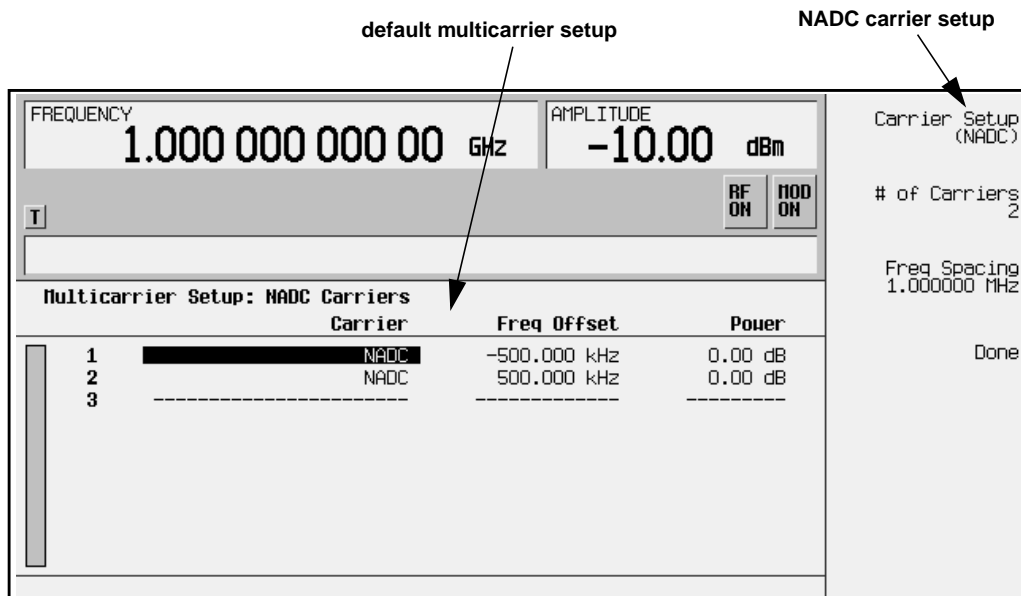

7. To set up 11 NADC carriers, press **# of Carriers > 11 > Enter**.
8. To set the frequency spacing between the carriers to 100 kHz, press **Freq Spacing > 100 > kHz**.

- Press **Done**. Notice that the first ten NADC carriers are displayed with the applied 100 kHz frequency offsets and 0 dB power, as shown in the following figure. To view the eleventh carrier, use the down arrow key to scroll down the list past carrier number ten. The next page displays carrier 11.

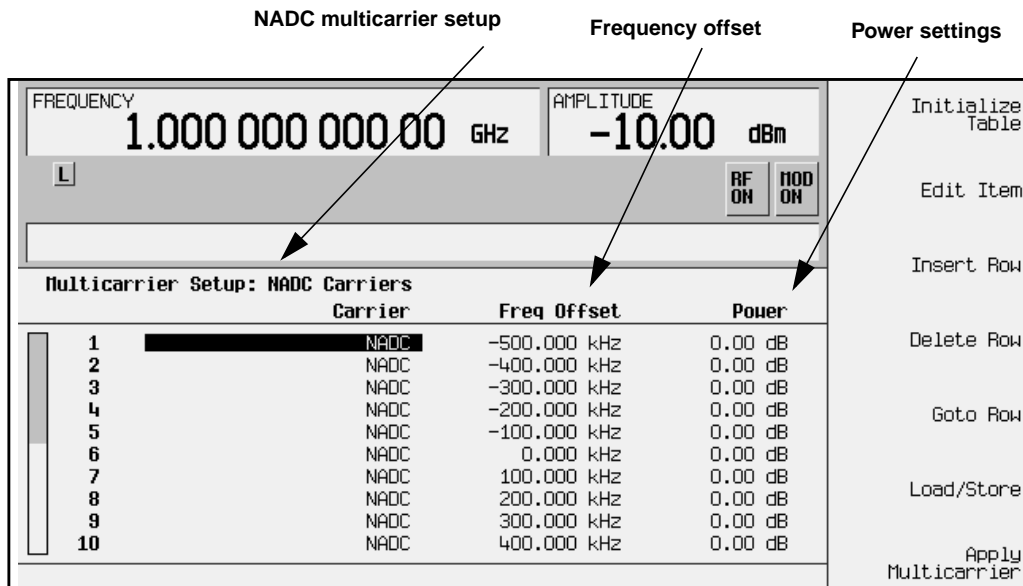

- To change the power or frequency offset for individual carriers, use the arrow keys to highlight the desired power notation or frequency offset; then use the numeric keypad to enter an amount, followed by the appropriate terminator softkey.

- Press **Return** once to return to the Digital Modulation menu.

- Toggle **Digital Modulation Off On** to **On**. Notice that the **DIGMOD** and **I/Q** annunciators are enabled on the front panel display. The signal generator builds all eleven waveforms as soon as Digital Modulation is turned on. The “Building waveform” status box appears for each waveform being built, as shown in the following figure.

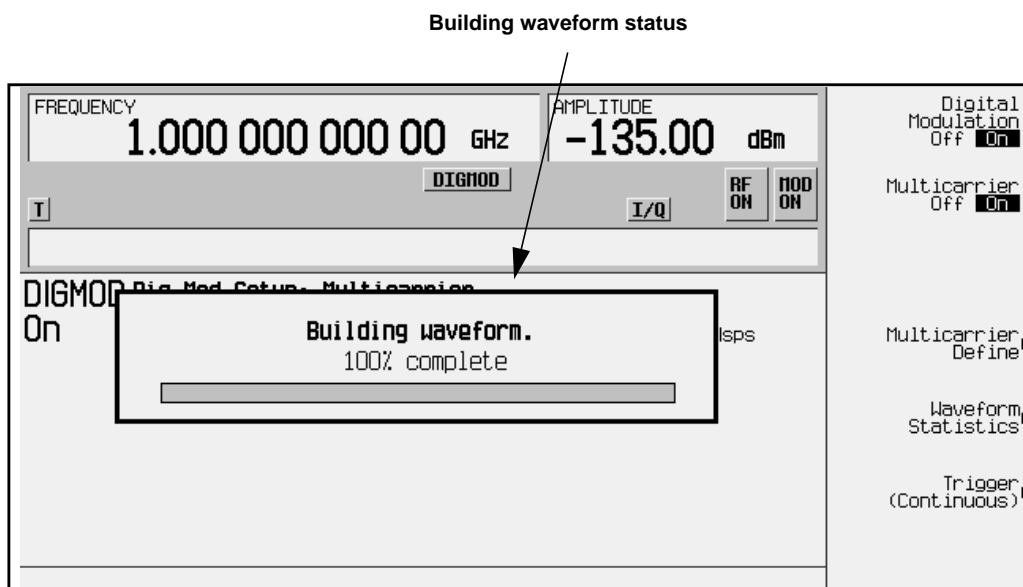

Creating a User-Defined FIR Filter Using the FIR Table Editor

Using this procedure you will create and store an 8-symbol, windowed sinc function filter with an oversample ratio of 4. (Option UN5 is required.)

Accessing the Table Editor

1. Preset the signal generator to normal preset conditions.
2. Press the front panel **Mode** key.
3. If you have multiple options and the **Arb Waveform Generator** softkey is visible, press it next.
4. Press **CDMA Formats > IS-95A > CDMA Define > Filter > Define User FIR**. The FIR table editor should now be displayed. The following figure shows the FIR table editor.



Entering the Coefficient Values

The FIR table editor creates a filter from values that you provide. In this example, the values you'll enter are listed after step 2.

1. Notice that the Value field for coefficient 0 is already highlighted. Use the numeric keypad to type the first value from the list. As you press the numeric keys, the numbers are displayed in the active entry area. (If you make a mistake, you can correct it using the backspace key.)

Terminate your entry by pressing the **Enter** softkey. Notice that the value for coefficient 0 is now displayed in the Value field and a second row is automatically displayed with the Value field highlighted. (The following figure shows the FIR table editor at this point in the process.)

FREQUENCY 4.000 000 000 00 GHz		AMPLITUDE -135.00 dBm		Edit Item Insert Row Delete Row Goto Row Mirror Table Oversample Ratio 4 More (1 of 2)
RF OFF		MOD ON		
FIR Values (UNSTORED)		Oversample Ratio: 4		
Coeff.	Value			
0	-0.000076			
1				

2. Continue entering the coefficient values until all 16 are complete.

Coefficient	Value
0	-0.000076
1	-0.001747
2	-0.005144
3	-0.004424
4	0.007745
5	0.029610
6	0.043940
7	0.025852

Coefficient	Value
8	-0.035667
9	-0.116753
10	-0.157348
11	-0.088484
12	0.123414
13	0.442748
14	0.767329
15	0.972149

Duplicating the First 16 Coefficients Using Mirror Table

In a windowed sinc function filter, the second half of the coefficients are identical to the first half in reverse order. The signal generator provides a mirror table function that automatically duplicates the existing coefficient values in the reverse order.

1. Press the **Mirror Table** softkey. The last 16 coefficients are automatically generated and the first of these coefficients (number 16) is highlighted. The following figure shows the display at this point in the process.

FREQUENCY		4.000 000 000 00 GHz		AMPLITUDE		-135.00 dBm		Edit Item	
T				RF OFF		MOD ON		Insert Row	
FIR Values (UNSTORED)				Oversample Ratio: 4				Delete Row	
Coeff.		Value						Goto Row▶	
10		-0.157348						Mirror Table	
11		-0.088484						Oversample Ratio 4	
12		0.123414						More (1 of 2)	
13		0.442748							
14		0.767329							
15		0.972149							
16		0.972149							
17		0.767329							
18		0.442748							
19		0.123414							

Setting the Oversample Ratio

The oversample ratio (OSR) is the number of filter taps per symbol. Acceptable values range from 1 through 32, where the maximum combination of symbols and oversampling ratio is 1024. An FIR filter selected for use in CDMA, however, cannot have more than 512 coefficients so the number of symbols and the oversample ratio should be selected accordingly.

For this example, the desired OSR is 4, which is the default, so no action is necessary.

Displaying a Graphical Representation of the Filter

The signal generator has the capability of graphically displaying the filter in both time and frequency dimensions.

1. To view the filter frequency response (calculated using a fast Fourier transform), press **More (1 of 2) > Display FFT**. The following graph will be displayed:

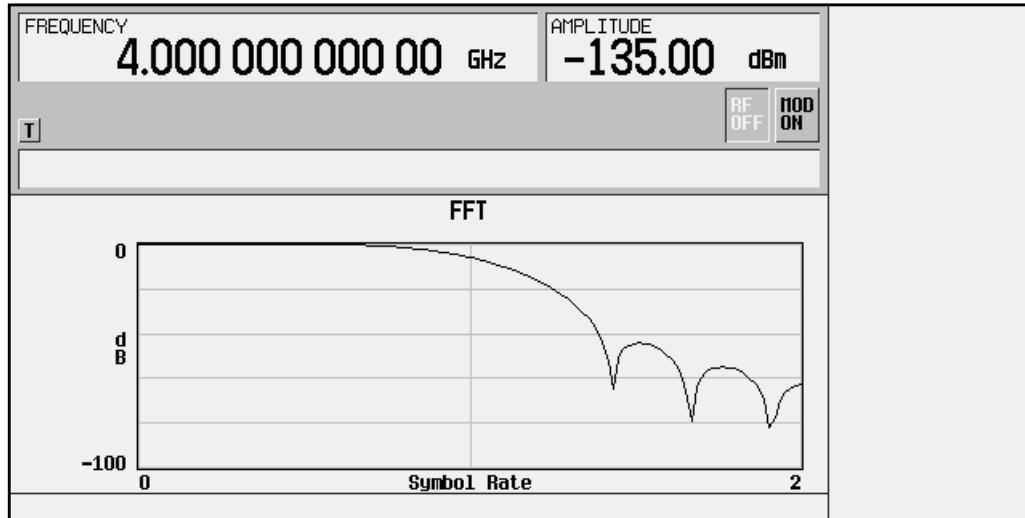

2. To return to the menu keys, press **Return**.
3. Display the filter impulse response in time by pressing **Display Impulse Response**. The following graph will be displayed:

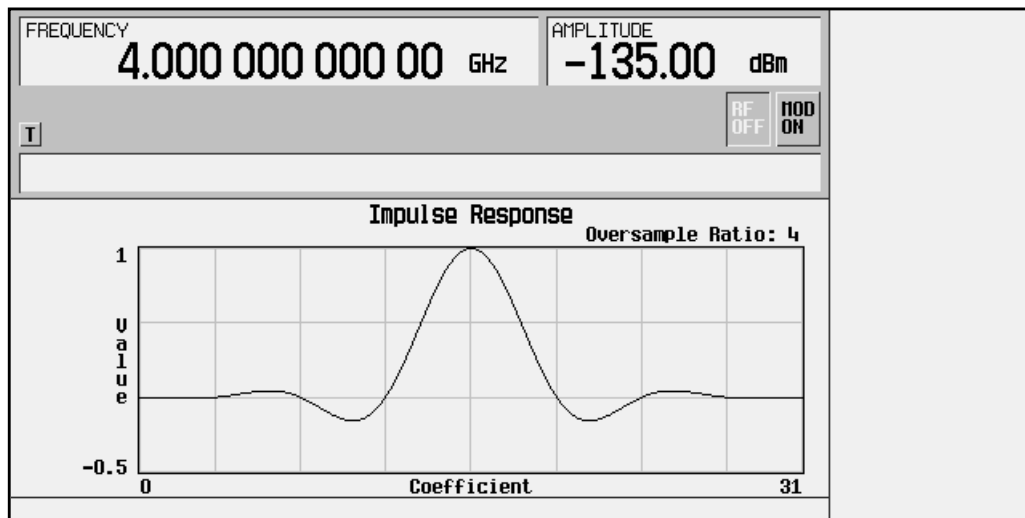

4. To return to the menu keys, press **Return**.

Storing the Filter to Memory

The filter is now complete and can be stored to non-volatile memory for future use. At any time you can check the information at the top of the FIR table editor to determine whether the current table has been stored. Your current table should display the following text: FIR Values (UNSTORED). If you attempt to exit the table editor mode without first storing to a file, the signal generator will first prompt you to confirm that you want to exit without storing to a file. If you do *not* want to exit after all, press Return. To store the file, perform the following steps.

1. Press Load/Store > Store To File. The catalog of FIR files is displayed along with the amount of memory available.
2. For this example, you'll title the file NEWFIR1. The file name is created by pressing the softkey containing the desired character, then selecting the softkey with that character from the subsequent menu. For example, press the HIJKLMN softkey. Then press the bottom softkey, N. N is displayed in the active entry area following the Store to: text.
3. Continue entering the characters for the file name until NEWFIR1 is displayed in the active entry area. (Use the numeric keypad to enter the number 1.)
4. Press Enter when the file name is complete. The contents of the current FIR table editor are stored to a file in non-volatile memory. Observe the display:

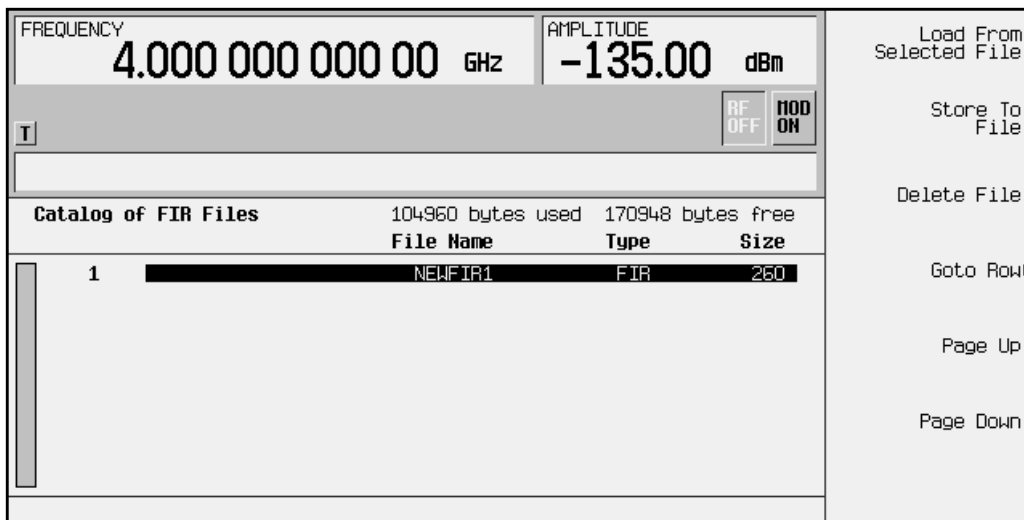

The NEWFIR1 file is the first file name listed. (If you have previously stored other FIR files, additional file names will be listed below NEWFIR1.) The file type is FIR and the size of the file is 260 bytes. The amount of memory used is also displayed. The number of files that can be saved depends on the size of the files and the amount of memory used. Memory is also shared by signal generator state files and list sweep files.

This filter can now be used to customize a modulation or it can be used as a basis for a new filter design. (Refer to the additional filter examples in this chapter.)

Modifying a FIR Filter Using the FIR Table Editor

FIR filters stored in signal generator memory can easily be modified using the FIR table editor. You can load the FIR table editor with coefficient values from user-defined FIR files stored in the signal generator's memory, or from one of the default FIR filters. Then you can modify the values, and store the new files. In this example, you'll load the FIR table editor with the values for a default Gaussian filter and then modify it. (Options UND and UN5 are both required.)

Loading a Default Gaussian FIR File

1. Preset the signal generator to normal preset conditions.
2. Press the front panel **Mode** key.
3. If you have multiple options and the **Arb Waveform Generator** softkey is visible, press it next.
4. Set the oversample ratio for the filter. (In this case, set it to 4). Press **CDMA Formats > IS-95A > CDMA Define > Filter > Define User FIR > Oversample Ratio**. If the oversample ratio is not already set to 4, press 4 and terminate the value with the **Enter** key.
5. To select a Gaussian filter, press **CDMA Formats > IS-95A > CDMA Define > Filter > Define User FIR > More (1 of 2) > Load Default FIR > Gaussian**.
6. Set the filter Bandwidth-multiplied-by-Time (BbT) value to 0.300 (if **Filter BbT** is not already set to this value). Press **Filter BbT** and rotate the front panel knob until 0.300 is displayed.
7. Set the number of filter symbols to 8 (if **Filter Symbols** is not already set to this value). Press **Filter Symbols** and rotate the front panel knob until 8 is displayed.
8. Press **Generate**. The FIR table editor should now contain the coefficient values for the specified Gaussian filter.

9. Press **Display Impulse Response** for a graphic representation of the filter impulse response as shown here:

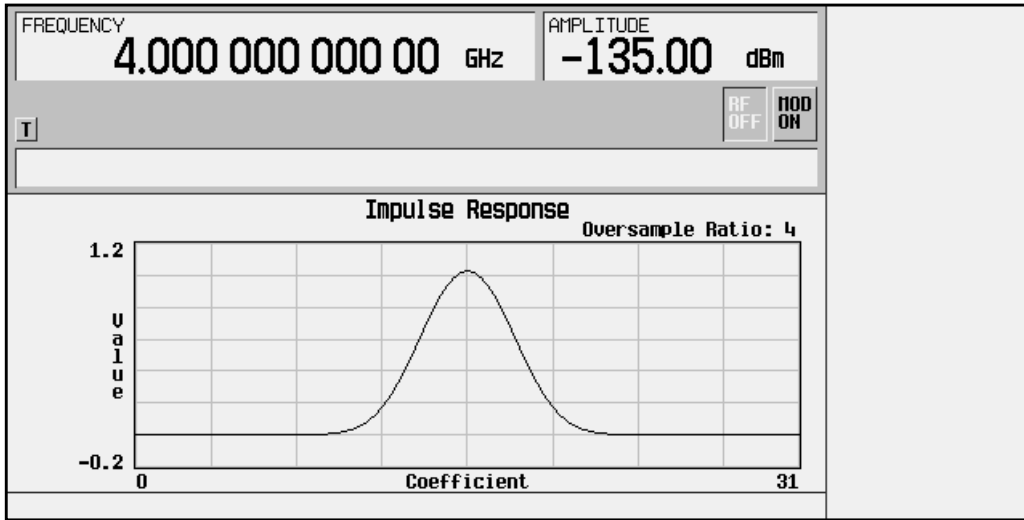

10. To return to the menu keys, press **Return**.

Modifying the Coefficients

1. The value for coefficient 0 should be highlighted. Use the front panel knob to scroll down until coefficient 15 is highlighted.
2. Press **0 > Enter** to change the value of the coefficient to 0.
3. Press **Display Impulse Response** to see the effects of the change.

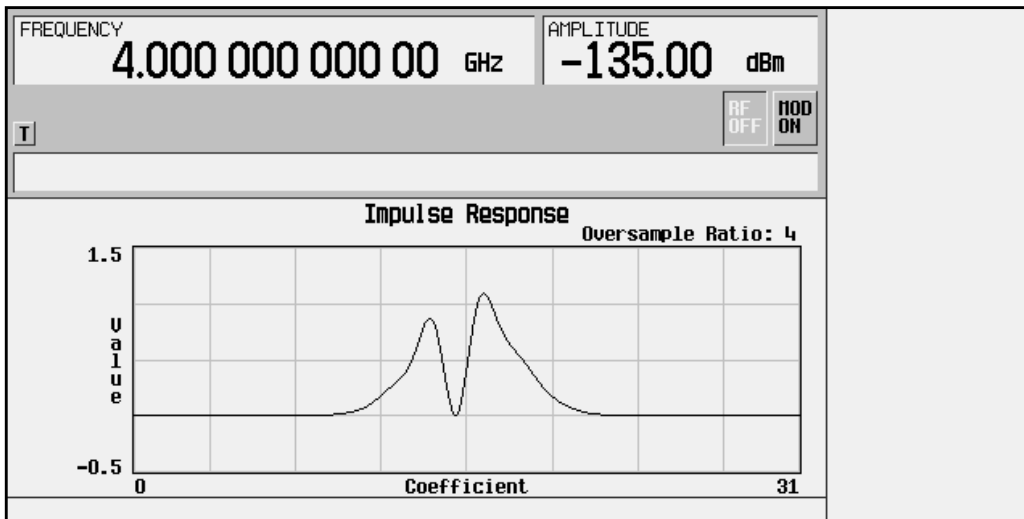

Notice that the graphic display can provide a useful troubleshooting tool (in this case indicating a missing coefficient value for a proper Gaussian response).

4. To return to the menu keys, press **Return**.

5. In addition to changing existing values, you can also insert and delete rows of coefficients and change the oversample ratio. Press **More (2 of 2)** to access these softkeys.
6. Change coefficient 15 back to its original value.
 - a. Use the front panel knob to highlight row 15.
 - b. Press **1 > Enter**.

Storing the Filter to Memory

1. Press **More 1 of 2 > Load/Store > Store To File**. The catalog of FIR files is displayed along with the amount of memory available.
2. Name the file NEWFIR2.
3. Press **Enter** when the file name is complete. The contents of the current FIR table editor are stored to a file in non-volatile memory, and the catalog of FIR files is updated to show the new file.

Applying a User-Defined FIR Filter to a CDMA State

Custom FIR filters can be created using the FIR table editor feature or they can be created externally and downloaded into signal generator memory. Once the filter is stored in memory, it can be selected for use with CDMA modulation. This example requires that at least one FIR file be already stored in memory. For an example of creating and storing an FIR filter, see “Creating a User-Defined FIR Filter Using the FIR Table Editor” on page 2-35. (Options UND and UN5 are both required.)

1. Preset the signal generator to normal preset conditions.
2. Press the front panel **Mode** key.
3. If you have multiple options and the **Arb Waveform Generator** softkey is visible, press it next.
4. Press **CDMA Formats > IS-95A > CDMA Define > Filter > Select > User FIR**. The catalog of FIR files should now be displayed. The following figure shows an example of the catalog.

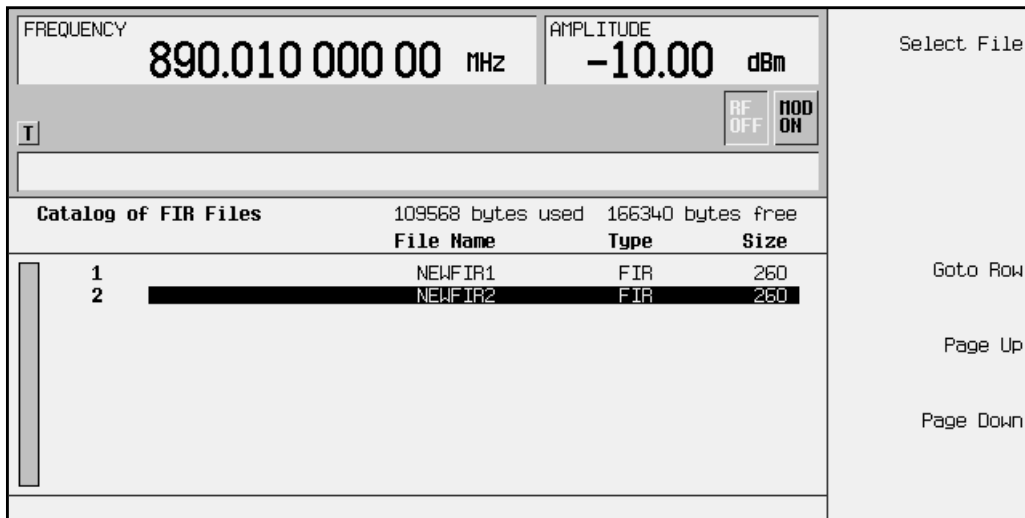

In this example, there are two FIR files listed: NEWFIR1 and NEWFIR2. (These files were created in the previous examples.)

5. Scroll down in the list until the desired filter is highlighted. In this example, NEWFIR2 is the desired filter. You can use the front panel knob or the arrow keys as well as the Goto Row function.

6. Press **Select File**. The highlighted filter is now selected for use in CDMA modulation. The following figure shows our example displayed.

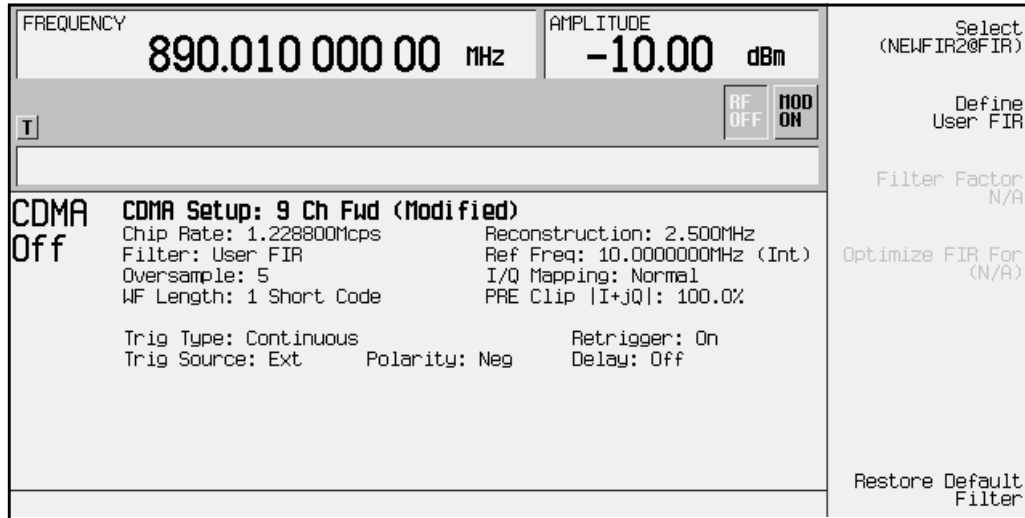

The filter you selected is NEWFIR2. You can see the name displayed in the Filter field near the left of the display. The **Select** softkey (at the top and right) displays **User FIR** to indicate that a user-defined FIR filter has been selected.

Once you have set the other CDMA parameters to your satisfaction, turn on both CDMA and the RF output and your user-defined filter is in use.

7. Notice that the oversample ratio has remained at the default value of 5. If you have designed your filter with a different oversample ratio, it will resample the filter to the specified oversample ratio unless you change the oversample ratio in the CDMA Define menu. In this example, the filter oversample ratio is 4, so make the following changes:

Press **Return** > **More (1 of 2)** > **Oversample Ratio**. Rotate the front panel knob until the number 4 is displayed in the active entry area.

Notice that although you can design a filter with an oversample ratio of up to 32 taps per symbol, the oversample ratio range possible with CDMA modulation is 2 through 8.

Using External Reconstruction Filters

You can use external reconstruction filters with the arbitrary waveform generator and the CDMA waveform generator by following the instructions listed in this section. Refer to the figure below.

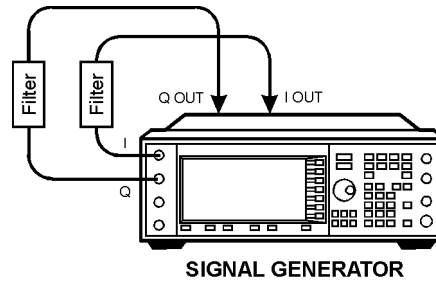

1. Using four 50-ohm BNC cables of identical length and filters with matching filter delay values, connect the filters between the rear panel I-OUT and Q-OUT connectors and the front panel I and Q input connectors.
2. Press **I/Q > I/Q Source > Ext I/Q**. This connects the input of the I/Q modulator to the front panel I and Q input connectors.
3. For CDMA signals, press **Mode > ARB Waveform Generator (if it appears) > CDMA Formats > IS-95A > CDMA Define > Reconstruction Filter > Through**. This disables the internal reconstruction filters.

For arbitrary waveform generator signals, press **Mode > ARB Waveform Generator (if it appears) > Dual ARB > ARB Setup > Reconstruction Filter > Through**.

NOTE This step is not necessary as long as you are using a reconstruction filter that has a smaller bandwidth than the active internal reconstruction filter. For example, if the internal reconstruction filter is set to 2.5 MHz and you would like to use a 1 MHz external filter, it is not necessary to set the internal reconstruction filter to **Through**.

Using the Multitone Waveform Generator

The examples in this section provide information on how to create a multitone waveform (on page 2-47), and how to use a stored multitone waveform (on page 2-52).

Table Editor Basics

While the following examples provide information specific to the multitone table editor (shown in the following figure), they do not go into detail on every possible way to edit information. The section “Table Editor Basics” on page 2-2 covers in detail many of the features common to most table editors.

Annotations in the figure:

- Active Entry Area
- Offset from center frequency, as defined in Initialize Table menu.
- Power
- Multitone softkey menu
- Tone number
- Relative Phase
- State column indicates whether a tone is turned on or off.

Multitone Setup: default				
Tone	Freq Offset	Power	Phase	State
1	-35.000 kHz	0.00 dB	0	On
2	-25.000 kHz	0.00 dB	0	On
3	-15.000 kHz	0.00 dB	0	On
4	-5.000 kHz	0.00 dB	0	On
5	5.000 kHz	0.00 dB	0	On
6	15.000 kHz	0.00 dB	0	On
7	25.000 kHz	0.00 dB	0	On
8	35.000 kHz	0.00 dB	0	On

pk731b

NOTE The signal generator firmware has been updated to include a feature that allows you to set the relative power levels for each multitone waveform generator tone. These instructions reflect this firmware change. If your signal generator is not equipped with this latest firmware, your multitone waveform generator will not have the ability to set the relative power levels of the tones. The steps that you use to create a multitone waveform will not include setting the relative power levels.

To upgrade your signal generator firmware to the most current version available, contact your nearest Agilent Technologies Sales and Service office.

Creating a Multitone Waveform

The following example walks you through creating and storing a simple 5-tone waveform. You can use this example to familiarize yourself with the various parameters that are available to customize this type of waveform.

Initialize the Multitone Table Editor

The first step in creating a multitone waveform is to set the number of tones and the frequency spacing between those tones. This is termed initializing the table editor, because this is the only way to set the frequencies and number of tones, and when you change either the number of tones or the frequency spacing, the relative power level of *all* tones is set to 0.00 dB, the phase of *all* tones is set to zero, and *all* tones are turned on.

1. Preset the signal generator, then press **Mode > ARB Waveform Generator** (if it appears) > **Multitone**. The signal generator displays the multitone table editor, which will look similar to the following figure.

FREQUENCY		AMPLITUDE		
4.000 000 000 00 GHz		-135.00 dBm		
Multitone Setup: default				
Tone	Freq Offset	Power	Phase	State
1	-35.000 kHz	0.00 dB	0	On
2	-25.000 kHz	0.00 dB	0	On
3	-15.000 kHz	0.00 dB	0	On
4	-5.000 kHz	0.00 dB	0	On
5	5.000 kHz	0.00 dB	0	On
6	15.000 kHz	0.00 dB	0	On
7	25.000 kHz	0.00 dB	0	On
8	35.000 kHz	0.00 dB	0	On

2. Press **Initialize Table > Number of Tones**.
3. Using the front panel knob, change the number of tones to 5.

Note that the **Number of Tones** softkey now displays the number of tones that was entered (5 in this example), but the number of tones in the table editor has not changed.

4. Press **Freq Spacing**.

Tones are evenly spaced about zero. When there are an even number of tones defined (as shown in the previous figure), the center two tones are placed on either side of zero. For an odd number of tones (as you specified in step 3), the center tone is placed *at* zero.

Also, if you set the frequency spacing less than approximately 5 kHz, the ALC can interact with the tones, causing some distortions as evidenced by intermodulation products outside the desired tones. To eliminate this effect, turn off the ALC.

5. Using the front panel number keys, enter **20**, then press the **kHz** softkey to terminate the entry.

Note in the figure below that the **Freq Spacing** softkey now displays the new spacing value, but that the values in the table editor have not changed.

The screenshot shows the Multitone Setup interface. At the top, the frequency is set to 4.000 000 000 00 GHz and the amplitude to -135.00 dBm. The frequency spacing is 20.000 kHz. Below this is a table with 8 tones. The first tone has a frequency offset of -35.000 kHz. The interface also includes softkeys for 'Initialize Phase' (Fixed/Random) and 'Random Seed' (Fixed/Random), and a 'Done' button.

Multitone Setup: default				
Tone	Freq Offset	Pouer	Phase	State
1	-35.000 kHz	0.00 dB	0	On
2	-25.000 kHz	0.00 dB	0	On
3	-15.000 kHz	0.00 dB	0	On
4	-5.000 kHz	0.00 dB	0	On
5	5.000 kHz	0.00 dB	0	On
6	15.000 kHz	0.00 dB	0	On
7	25.000 kHz	0.00 dB	0	On
8	35.000 kHz	0.00 dB	0	On

NOTE The **Initialize Phase Fixed Random** and the **Random Seed Fixed Random** softkeys are displayed in the figure above. These softkeys are not used in this procedure as described but they could be used if you wanted to set the tones to random phases.

- The **Initialize Phase Fixed Random** softkey is used to select either fixed or random phase settings for the tones. Selecting the **Fixed** softkey will set the phase of all of the tones to 0 degrees. Selecting the **Random** softkey will set the phase of the tones to randomly generated phase values based on selected setting of the **Random Seed Fixed Random** softkey.
- The **Random Seed Fixed Random** softkey is used to select either a fixed seed or a random seed for the randomly generated phases. Selecting the **Fixed** softkey will generate the same random phases after each initialization. Selecting the **Random** softkey will generate new phases after each initialization.

6. To enter the new values into the table editor, press the softkey **Done**.

Note that there are now five tones listed in the table editor, and that the values listed in the Freq Offset column are 20 kHz apart, with the center tone at 0.000 kHz.

FREQUENCY: 4.000 000 000 00 GHz AMPLITUDE: -135.00 dBm

Multitone Setup: default (UNSTORED)

Tone	Freq Offset	Power	Phase	State
1	-40.000 kHz	0.00 dB	0	On
2	-20.000 kHz	0.00 dB	0	On
3	0.000 kHz	0.00 dB	0	On
4	20.000 kHz	0.00 dB	0	On
5	40.000 kHz	0.00 dB	0	On

Softkeys: Multitone Off On, Initialize Table, Edit Item, Toggle State, Apply Multitone, Goto Row, More (1 of 2)

Set the Power

When the table is first initialized, all power values are set to 0.00 dB. The power levels set in the table editor are relative to an arbitrary 0 dB reference. The cumulative power of all of the tones is equal to the amplitude shown in the amplitude area of the display. You can use the table editor to change the relative power level of any tone.

1. Using the front panel arrow keys, highlight the Power entry for the second tone.
2. Select the softkey **Edit Item**.
3. Using the front panel number keys, press +/- > 4.5, then press the **dB** softkey to terminate the entry.

The second tone is updated with a relative power level of -4.50 dB, and phase value of the second tone is highlighted.

FREQUENCY: 4.000 000 000 00 GHz AMPLITUDE: -135.00 dBm

Multitone Setup: default (UNSTORED)

Tone	Freq Offset	Power	Phase	State
1	-40.000 kHz	0.00 dB	0	On
2	-20.000 kHz	-4.50 dB	0	On
3	0.000 kHz	0.00 dB	0	On
4	20.000 kHz	0.00 dB	0	On
5	40.000 kHz	0.00 dB	0	On

Softkeys: Multitone Off On, Initialize Table, Edit Item, Toggle State, Apply Multitone, Goto Row, More (1 of 2)

Set the Phase

When the table is first initialized, all phases are 0; this is a phase aligned condition, and the peaks of each tone will all add up to a high peak at points in the waveform. By changing the phases in the table editor, you can make different levels of peaks. You can view this peak information using the View Statistics → CCDF function (**Mode** > **ARB Waveform Generator** (if it appears) > **Multitone** > **(More 1 of 2)** > **Waveform Statistics** > **Plot CCDF**).

1. Using the front panel arrow keys, highlight the Phase entry for the third tone.
2. Select the softkey **Edit Item**.
3. Using the front panel number keys, enter 123, then press the **deg** softkey to terminate the entry.

The third tone is updated with a phase of 123 degrees, and state of tone 4 is highlighted.

The screenshot shows the Multitone Setup screen. At the top, the main display shows FREQUENCY: 4.000 000 000 00 GHz and AMPLITUDE: -135.00 dBm. Below this is a table titled "Multitone Setup: default (UNSTORED)". The table has columns for Tone, Freq Offset, Pouer, Phase, and State. The third row (Tone 3) has a phase of 123 and its State is highlighted. The fourth row (Tone 4) has its State highlighted. To the right of the table is a vertical list of softkeys: Multitone (Off/On), Initialize Table, Edit Item, Toggle State, Apply Multitone, Goto Row, and More (1 of 2).

Tone	Freq Offset	Pouer	Phase	State
1	-40.000 kHz	0.00 dB	0	On
2	-20.000 kHz	-4.50 dB	0	On
3	0.000 kHz	0.00 dB	123	On
4	20.000 kHz	0.00 dB	0	On
5	40.000 kHz	0.00 dB	0	On

Remove any Unwanted Tones

You can remove a tone to view, for example, the intermodulation caused by the remaining tones.

1. Using the front panel arrow keys, highlight the State entry for the fourth tone.
2. Select the softkey **Toggle State**.

Note that in the State column, the fourth tone now displays Off.

The screenshot shows the Multitone Setup interface. At the top, the frequency is 4.000 000 000 00 GHz and the amplitude is -135.00 dBm. Below this is a table with the following data:

Tone	Freq Offset	Power	Phase	State
1	-40.000 kHz	0.00 dB	0	On
2	-20.000 kHz	-4.50 dB	0	On
3	0.000 kHz	0.00 dB	123	On
4	20.000 kHz	0.00 dB	0	Off
5	40.000 kHz	0.00 dB	0	On

On the right side of the screen, there are several softkey options: Multitone (Off/On), Initialize Table, Edit Item, Toggle State, Apply Multitone, and Goto Row. At the bottom right, it says 'More (1 of 2)'.

Save the Multitone Setup.

Now that you have created a custom multitone waveform, you can save it for future use. When changes made to the default table have not been stored, (UNSTORED) appears as shown in the following figure. Also, when you load and edit a Multitone setup table from a stored file (see “Using a Stored Multitone Waveform” on page 2-52 for instructions on how to do this), (Modified) is displayed after the file name until you store the waveform.

Indicates that the data in the table editor has not been stored.

This screenshot is identical to the one above, but with a jagged red line drawn under the table header 'Multitone Setup: default (UNSTORED)'. An arrow points from the explanatory text above to this red line.

1. In the softkey menu, press **More 1 of 2 > Load/Store > Store To File**. The catalog of files appears, with the name of stored files, and amount of memory used and available (in bytes).
2. Name this file **5_TONE**. If there is already a file highlighted in the CDMA catalog, press **Edit Keys > Clear Text > 5 > VWXYZ_\$ > _ > OPQRSTU > T > OPQRSTU > O > HIJKLMN > N > ABCDEF > E** and terminate the entry by pressing **Enter**. You now have a file called **5_TONE** stored in the signal generator’s volatile ARB memory.

For complete instructions on naming a file, refer to “Storing a Custom CDMA State to Memory” on page 2-11.

Using a Stored Multitone Waveform

Once you have created and stored a multitone waveform, you can use that information as described in the following steps.

Selecting a Multitone Waveform

1. Press the front panel **Mode** key, then press **Arb Waveform Generator** [if it appears] > **Multitone**.
2. To display the catalog of stored multitone files, press **(More 1 of 2) > Load/Store**.
3. Highlight the file you want to use, then press **Load From Selected File > Confirm Load From File**. The information from the file is loaded and displayed in the table editor, as shown in the figure below.

FREQUENCY		4.000 000 000 00 GHz		AMPLITUDE		-135.00 dBm		Load/Store▶
T				RF OFF		MOD ON		Waveform, Statistics▶
Multitone Setup: 5_TONE								
	Tone	Freq Offset	Power	Phase	State			
	1	-40.000 kHz	0.00 dB	0	On			
	2	-20.000 kHz	-4.50 dB	0	On			
	3	0.000 kHz	0.00 dB	123	On			
	4	20.000 kHz	0.00 dB	0	Off			
	5	40.000 kHz	0.00 dB	0	On			
						More (2 of 2)		

Turning On a Multitone Modulation

Once you have selected a multitone waveform, use the following steps to turn it on.

1. Press **Return** to open the Multitone menu.
2. In the Multitone menu, press the softkey **Multitone Off On** to highlight **On**.
Note that the front panel annunciators **M-Tone** and **I/Q** turn on.
3. Press the front panel **Frequency** hardkey and then set the desired frequency.
4. Press the front panel **Amplitude** hardkey and then set the desired amplitude.
5. If necessary, press the front panel **Mod On/Off** hardkey until the **MOD ON** annunciator appears. This applies the custom modulation to the carrier.
6. If the RF is not on (the **RF OFF** annunciator is displayed), press the front panel **RF On/Off** hardkey. The display annunciator changes to **RF ON**, and the custom modulated signal is available at the RF OUTPUT connector.

NOTE	If you edit parameters in a multitone modulation <i>after</i> you turn multitone on, select the softkey Apply Multitone to regenerate the updated multitone waveform.
-------------	--

Building a Waveform Sequence

Follow the guidelines in this section to learn how to build waveform sequences from waveform segments using the dual arbitrary waveform generator. (Options UND and UN5 are both required.)

In this example, you will generate two different types of CDMA waveform segments, a 64 channel forward and a 9 channel forward signal. After you have the two waveform segments stored in NVARB memory, you will build a sequence using each one of these waveform segments.

NOTE There are two kinds of arbitrary waveform generator memory: ARB memory and NVARB memory.

ARB memory is volatile. Data held in ARB memory is destroyed if the signal generator's line power is cycled.

NVARB memory is non-volatile. Data held in NVARB memory is *not* destroyed if the signal generator's line power is cycled.

For more information on ARB and NVARB memory, see [“Managing Volatile and Non-Volatile ARB Memory”](#) on page 4-4.

Generating the First Waveform

There are two ways to provide waveforms for use by the sequencing and playback sections of the signal generator. You can either download a waveform via GPIB or generate a waveform in a CDMA format. For information on downloading waveforms via GPIB, see [“Downloading Waveform Files Into Memory”](#) on page 2-72. The following procedure shows how you can generate a waveform using the IS-95A CDMA (Option UN5) format. For information on generating waveforms using other CDMA formats, refer to the user's and programming guide for the specific CDMA format option.

To generate the first waveform using the CDMA format:

1. Press the front panel **Preset** key.
2. Press **Mode** > **Arb Waveform Generator** (if it appears) > **CDMA Formats** > **IS-95A**.
3. Press the **Setup Select** softkey, then press **64 Ch Fwd** to select a 64-channel forward CDMA template.

- Press **CDMA Off On** until **On** is highlighted. The signal generator generates the 64 channel forward CDMA waveform and stores it in ARB (volatile) memory with the name AUTOGEN_WAVEFORM (the default name given to any waveform generated in the CDMA format).

NOTE There can only be one AUTOGEN_WAVEFORM waveform in ARB memory at any given time.

Therefore, you must rename this file, clearing the way for a second CDMA waveform.

- Press **Return** twice, then press **Dual ARB**. This returns you to the main arbitrary waveform generator menu.

Renaming the First Waveform as a Waveform Segment

- Press **Waveform Segments**. This opens a menu that enables you to rename the waveform as a waveform *segment*. Later in the process, the two waveform segments, 64 channel forward and 9 channel forward, will be combined to form a waveform sequence.

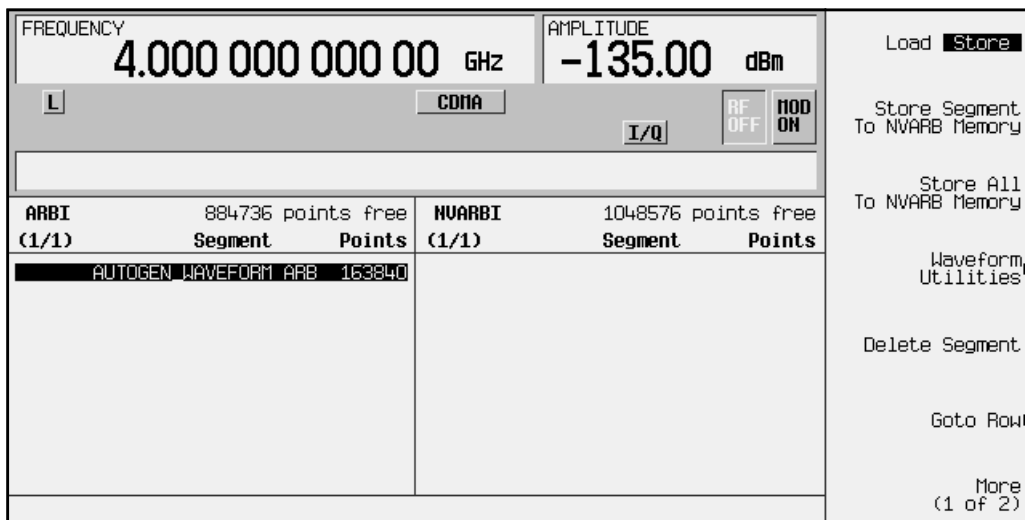

- Press **More (1 of 2) > Rename Segment > Editing Keys > Clear Text**. You are now ready to enter a new file name for the 64 channel forward CDMA waveform segment.

- Press **64** > **ABCDEFGF** > **C** > **HIJKLMN** > **H** > **ABCDEFGF** > **F** > **Enter**. The waveform segment file name has now been changed to **64CHF**.

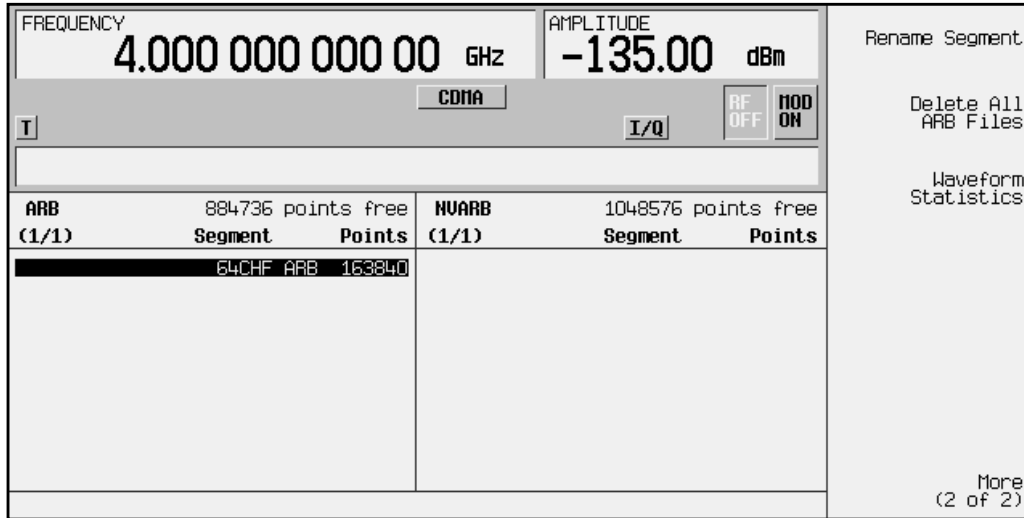

Generating the Second Waveform

- Press **Mode** > **Arb Waveform Generator** (if it appears) > **CDMA Formats** > **IS-95A**.
- Press **Setup Select** > **9 Ch Fwd** to select a 9-channel forward CDMA template.
- The signal generator generates the 9 channel forward CDMA waveform and stores it in ARB (volatile) memory with the name **AUTOGEN_WAVEFORM**, the default name given to any waveform generated in the CDMA format. (This is why you renamed the 64 channel forward CDMA waveform, so as not to overwrite it with this 9 channel forward CDMA waveform.)
- Press **Return** twice, then press **Dual ARB**. This will return you to the main arbitrary waveform generator menu.

Renaming the Second Waveform as a Waveform Segment

- Press **Waveform Segments**. This opens a menu that enables you to rename the waveform as a waveform segment. Use the front panel knob to highlight **AUTOGEN_WAVEFORM**.
- Press **More (1 of 2)** > **Rename Segment** > **Editing Keys** > **Clear Text**. You are now ready to enter a new name for the 9 channel forward CDMA waveform segment.
- Press **9** > **ABCDEFGF** > **C** > **HIJKLMN** > **H** > **ABCDEFGF** > **F** > **Enter**. The name has now been changed to **9CHF**.
- Press **Return**. This will take you to the main arbitrary waveform generator menu.

Building a Waveform Sequence from Two Waveform Segments

1. Press **Waveform Sequences > Build New Waveform Sequence**. This opens a menu for building new waveform sequences. The left side of the display is a catalog listing of the waveform segments and sequences in ARB memory. The right side of the display is a sequential listing of waveform segments that define the waveform sequence.

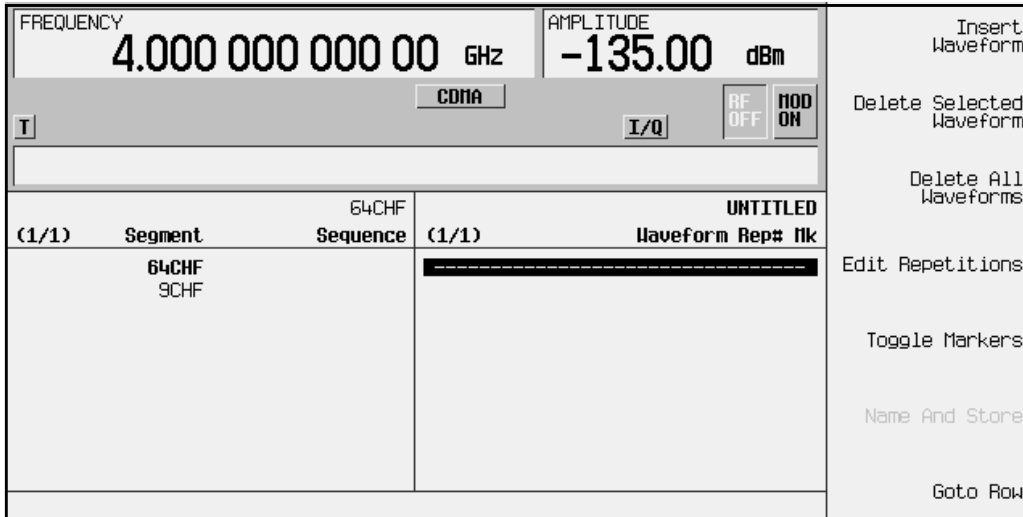

2. Press **Insert Waveform**. This moves the highlight bar over to the catalog listing of waveform segments. Use the arrow keys or the front panel knob to highlight **64CHF**.
3. Press **Insert Selected Waveform**. This inserts one repetition of the 64 channel forward CDMA waveform segment into the sequence playback listing on the right side of the display. Under the table heading **Waveform** you will see **ARB: 64CHF**, and under the table heading **Rep#** you will see **1**. The sequencer has now been programmed to play back one repetition of the 64 channel forward CDMA waveform segment.

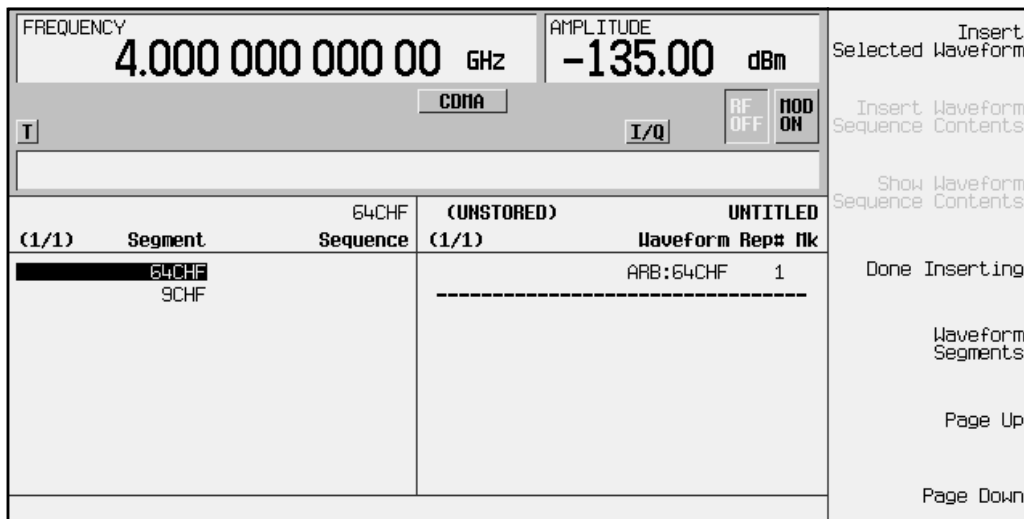

- Use the arrow keys or the front panel knob to highlight the 9CHF waveform segment. Press **Insert Selected Waveform**. This inserts one repetition of the 9 channel forward CDMA waveform segment into the sequence playback listing below the 64 channel forward waveform segment. Under the table heading *Waveform* you will see the addition of ARB:9CHF, and under the table heading *Rep#* you will see an additional 1.

FREQUENCY 4.000 000 000 00 GHz		AMPLITUDE -135.00 dBm		Insert Selected Waveform Insert Waveform Sequence Contents Show Waveform Sequence Contents Done Inserting Waveform Segments Page Up Page Down
CDMA		I/Q		
I		RF OFF		
		MOD ON		
(1/1)	Segment	9CHF Sequence	(UNSTORED) (1/1)	UNTITLED
	64CHF			ARB:64CHF 1
	9CHF			ARB:9CHF 1

- Press **Done Inserting**. The sequence has now been defined as one repetition of the 64 channel forward CDMA waveform segment followed by one repetition of the 9 channel forward CDMA waveform segment.

Editing the First and Second Waveform Segment Repetitions

- Use the front panel knob or the arrow keys to highlight the ARB:64CHF sequence entry. Press **Edit Repetitions**. Repetitions: 1 is displayed in the active entry area of the display. Press **5 > Enter**. The number of repetitions for the sequence entry ARB:64CHF has been changed to 5 and the highlight has moved over the sequence ARB:9CHF entry.

- Press **Edit Repetitions**. Repetitions: 1 is displayed in the active entry area of the display. Press: **8 > Enter**. The number of repetitions for the sequence entry ARB:9CHF has been changed to 8.

FREQUENCY 4.000 000 000 00 GHz		AMPLITUDE -135.00 dBm		Insert Waveform Delete Selected Waveform Delete All Waveforms Edit Repetitions Toggle Markers Name And Store Goto Row
CDMA		I/Q	RF OFF MOD ON	
(1/1)	Segment	9CHF Sequence	(UNSTORED) (1/1) Waveform Rep# Nk	
	64CHF 9CHF		ARB:64CHF 5 ARB:9CHF 8	

Naming and Storing the Waveform Sequence

- Press **Name and Store**. Store: is displayed in the active entry area of the display.
- Using the alphabetical softkeys and the numeric keypad, name the sequence 64CHFX5+9CHFX8. After inputting the sequence name and pressing **Enter**, the sequence is automatically stored in the sequence (Seq) section of the signal generator's memory catalog.

FREQUENCY 4.000 000 000 00 GHz		AMPLITUDE -135.00 dBm		Insert Waveform Delete Selected Waveform Delete All Waveforms Edit Repetitions Toggle Markers Name And Store Goto Row
CDMA		I/Q	RF OFF MOD ON	
(1/1)	Segment	9CHF Sequence	64CHFX5+9CHFX8 (1/1) Waveform Rep# Nk	
	64CHF 9CHF	64CHFX5+9CHFX8	ARB:64CHF 5 ARB:9CHF 8	

Playing the Waveform Sequence

1. Press **Return** twice to return to the top level menu (**ARB Off On** is the first softkey).
2. Press **Select Waveform**. This opens a menu from which you can select waveform segments or waveform sequences to be played.
3. Use the arrow keys or the front panel knob to highlight the waveform sequence 64CHFX5+9CHFX8. Press **Select Waveform**. This selects the waveform sequence to be played through the signal generator's I/Q section.

Select Waveform		64CHFX5+9CHFX8	
(1/1)	Segment	Points	Sequence Segs
	64CHF ARB	163840	64CHFX5+9CHFX8 SEQ 2
	9CHF ARB	163840	

4. Press **ARB Off On** until **On** highlights. The **I/Q** and **ARB** annunciators appear. This activates the waveform and plays it out of the dual arbitrary waveform generator.

To see this signal at the RF output, enter the appropriate frequency and amplitude settings (for example, press **Frequency** > **890.01** > **MHz** and **Amplitude** > **-10.0** > **dBm**, for a carrier at 890.01 MHz at a power level of -10 dBm), activate the modulation (**Mod Off On** set to **On**), and activate the RF output (**RF Off On** set to **On**).

Using Markers

The signal generator has two markers that you can place on a waveform segment; markers provide auxiliary output signals that are synchronized with a waveform segment. You can construct these output signals as a trigger signal to synchronize another instrument to a given portion of a waveform.

In some situations, it can be useful to use the markers to generate a clock signal. Using a CDMA waveform as a waveform segment (an `AUTOGEN_WAVEFORM ARB`), for example, the ARB sample clock frequency is a multiple of the chip rate. Using markers and the *# Skipped Points* feature, you can construct a clock at the chip rate easily.

Placing Markers on a Waveform Segment

Marker 1 → Event 1

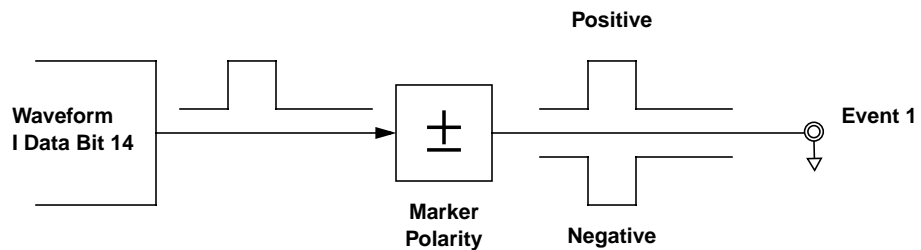
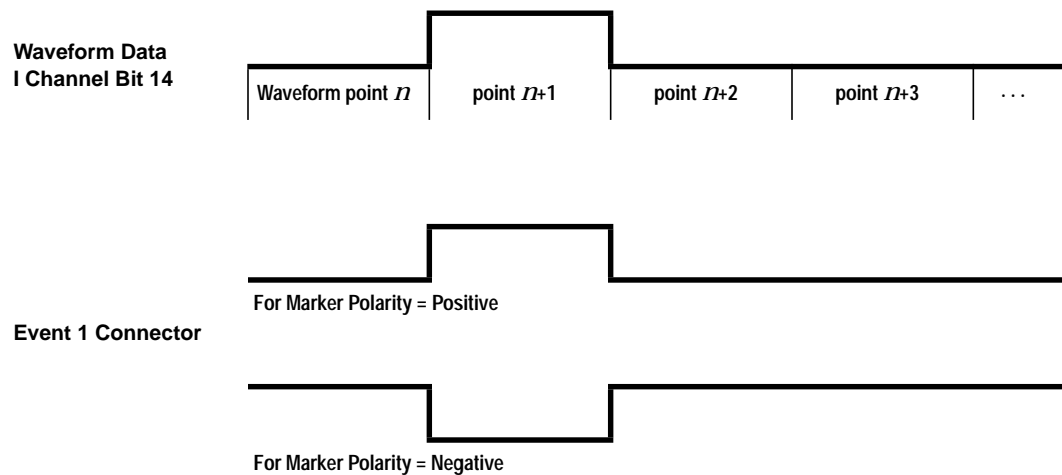

Marker 2 → Event 2

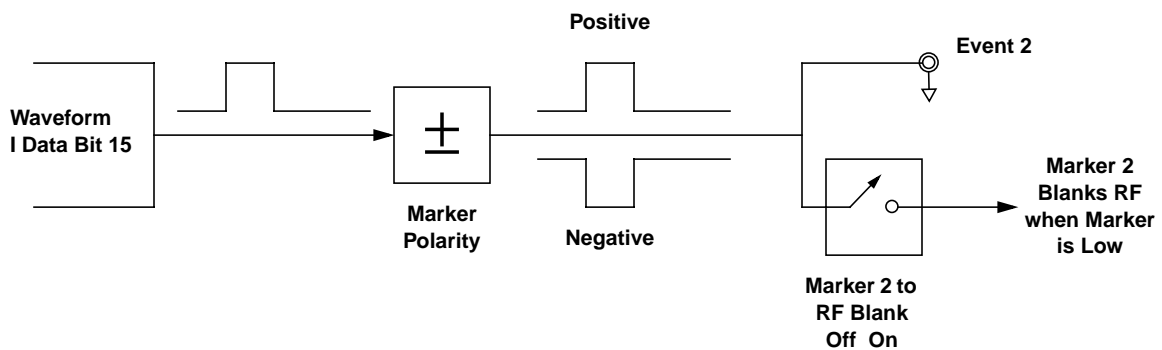
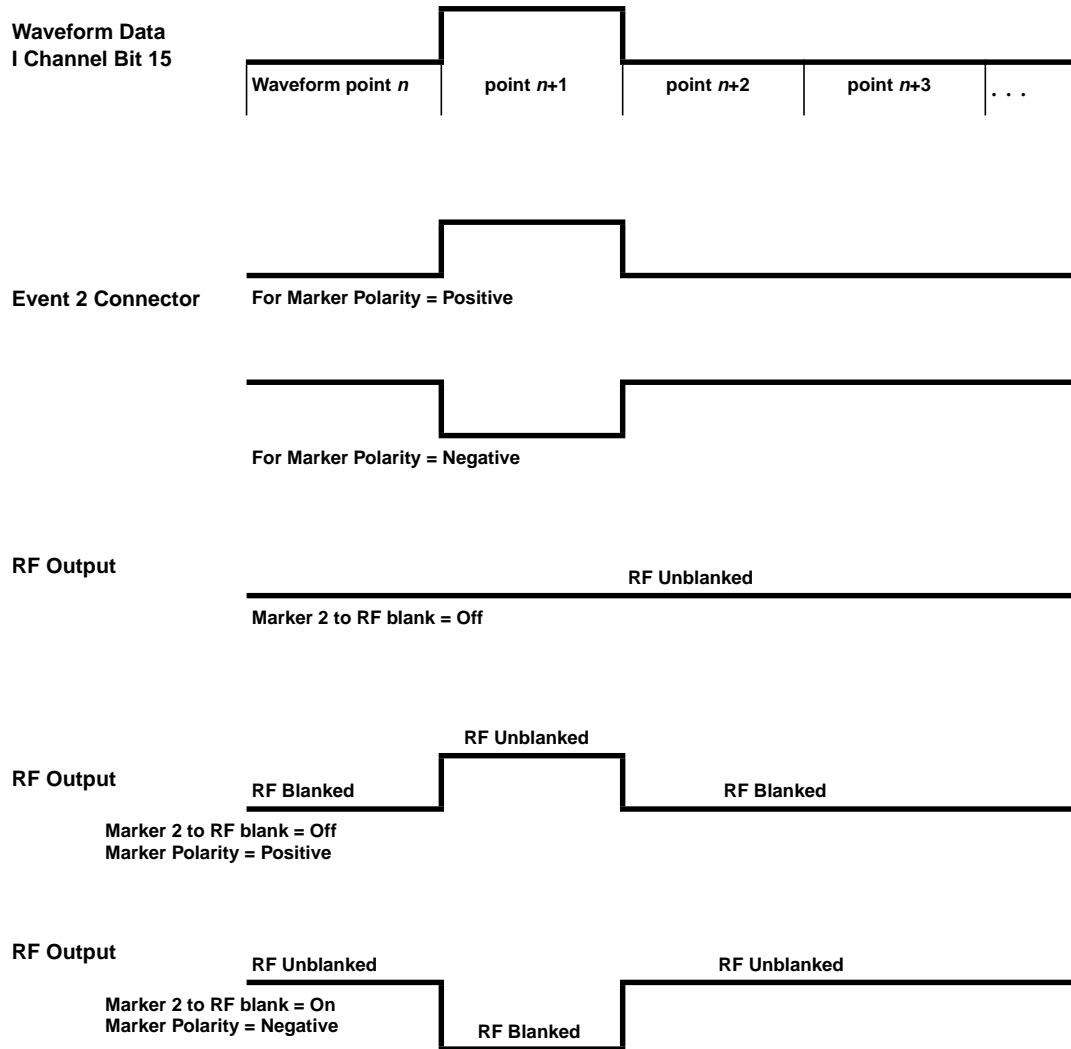

Placing a Marker at the Beginning of the Waveform Segment

You can put a marker at the beginning of a segment to create a trigger output that is synchronous with the start of that waveform segment.

1. Create/select a waveform segment (for details, refer to [“Generating the First Waveform”](#) on page 2-54).
2. Press: **Mode** > **ARB Waveform Generator** (if it appears) > **Dual ARB** > **Waveform Segments** > **Waveform Utilities** > **Set Markers** > **Set Marker On First Point**

This sets Marker 1 (selected by default) on the first point in the waveform segment.

Checking a Marker

Once you set a marker on a waveform segment, you can see the results at the Event 1/2 output (Event 1 for this example).

1. With the desired segment selected, press **Return** three times to display the Dual ARB softkey menu.
2. Press **ARB Off On** to select **On**. The **ARB** and the **I/Q** annunciators turn on.
3. Connect an oscilloscope to the Event 1 output, and trigger on the Event 1 signal. When a marker is present, a trigger occurs.

Placing a Marker Across a Range of Points

You can place a marker across a range of points, as well as at a single point.

1. Create/select a waveform segment (for details, refer to [“Generating the First Waveform”](#) on page 2-54).
2. Press **Mode** > **ARB Waveform Generator** (if it appears) > **Dual ARB** > **Waveform Segments** > **Waveform Utilities** > **Set Markers** > **Marker 1 2** (to select marker 2) > **Set Marker On Range of Points**.
3. Set the first and last points for the marker, then press **Apply To Waveform**.

If you enter a value for either the first marker point or the last marker point that would make the first marker point occur *after* the last, the last marker point is automatically adjusted to match the first marker point.

You can check this marker as described previously (at the Event 2 output for this example).

Using Markers in a Waveform Sequence

A waveform sequence comprises waveform segments. When you combine segments to form a sequence, you can enable or disable marker 1 and/or marker 2 on a segment-by-segment basis.

When you select a sequence to output, the markers embedded in any one segment of that sequence are output only if the sequence marker for that segment is enabled (toggled on). This makes it possible to output markers for some segments in a sequence, but not for others.

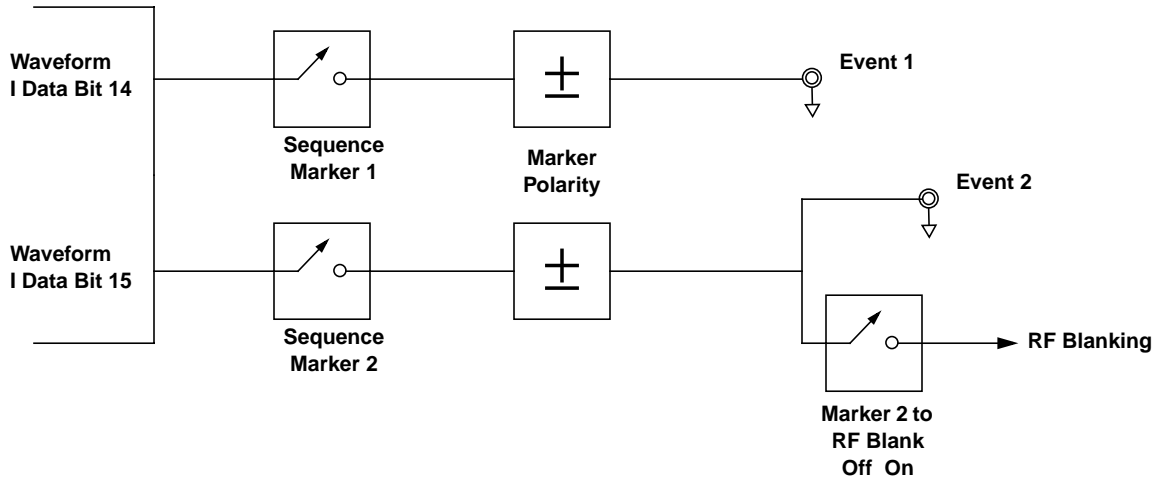

Toggling Markers in an Existing Waveform Sequence

In a waveform sequence, you can toggle the markers of each segment independently. When you build a waveform sequence, the markers on each segment are in the last marker toggle state that was used.

1. Press **Mode** > **ARB Waveform Generator** (if it appears) > **Dual ARB** > **Waveform Sequences**.
2. Select the desired waveform sequence.
3. Press **Edit Selected Waveform Sequence**. Note that the entries in the **Mk** column for each segment indicates whether a marker is on. No entry in that column means that both markers are off.

(1/1)	Segment	AUTOGEN_WAVEFORM Sequence	(1/1)	Waveform	Rep#	Mk
	AUTOGEN_WAVEFORM	SEQ3		ARB:AUTOGEN_WAVEFORM	1	1 2

Insert Waveform
 Delete Selected Waveform
 Delete All Waveforms
 Edit Repetitions
 Toggle Markers
 Name And Store
 Goto Row

Marker Column
This entry shows both markers on.

4. Using the front panel knob, move the highlight to select the desired segment.
5. Press **Toggle Markers**, then select the marker that you wish to toggle (**Toggle Marker 1** or **Toggle Marker 2**). You can toggle either one of the markers, or both.
6. Use the front panel arrow keys to move the highlight to the next desired segment, and toggle the markers for that segment. Continue with the remaining segments.
7. When you have all markers set as you wish, press **Return**, where you can name and store the edited waveform sequence.

Toggling Markers As You Create a Waveform Sequence

You can combine waveform segments to create a waveform sequence, and toggle the markers of each segment independently.

1. Press **Mode** > **ARB Waveform Generator** (if it appears) > **Dual ARB** > **Waveform Sequences** > **Build New Waveform Sequence**.
2. Refer to [“Building a Waveform Sequence”](#) on page 2-54 for details on how to build a waveform sequence.
3. To toggle markers:
 - a. Press **Mode** > **ARB Waveform Generator** (if it appears) > **Dual ARB** > **Waveform Sequences**.
 - b. Select the desired waveform sequence.
 - c. Press **Edit Selected Waveform Sequence**. Note that the **Mk** entry for each segment indicates whether a marker is on. No entry in that column means that both markers are off.
 - d. Using the front panel knob, move the highlight to select the desired segment.
 - e. Press **Toggle Markers**, then select the marker that you wish to toggle (**Toggle Marker 1** or **Toggle Marker 2**). You can toggle either one of the markers, or both.
 - f. Use the front panel arrow keys to move the highlight to the next desired segment, and toggle the markers for that segment. Continue with the remaining segments.
 - g. When you have all markers set as you wish, press **Return**, where you can name and store the edited waveform sequence.

Scaling Waveform Segments

The scaling feature can be used to scale waveform segments. It scales the waveform segments by changing the peak-to-peak output value of the selected waveform segment to a desired percentage of its full-scale value. Scaling has two purposes. First, scaling can be used to reduce the distortion that may be present with the waveform set at its full scale. Scaling can also be used to scale I and Q rear panel output levels of IS-95A signals generated by Option UN5. By setting scaling for the AUTOGEN_WAVEFORM waveform, you can change the I and Q signals from the default value. A waveform segment must be selected in the volatile ARB waveform memory before it can be scaled. The scaling can be set from 1 to 100% in 0.01% increments.

NOTE The output of the Dual ARB waveform is determined by the least significant 14 bits of a 2-byte integer (see “Waveform Composition” on page 4-6). As the waveform is scaled down, it can lose bits of resolution. Once a bit of resolution is lost, it can not be regained by increasing the scaling value of the waveform.

To scale a waveform segment:

1. If the signal generator is in remote mode, first press the **Local** key to return the signal generator to local control. Press the **Mode** key.
2. Press **Arb Waveform Generator** (if it appears). Then press **Dual ARB > Waveform Segments**.
3. If you want to scale a waveform segment that is not in the volatile ARB waveform memory, press **Load Store** so that **Load** is selected. If more than one waveform segment is present in the non-volatile ARB waveform memory (NVARBI), use the directional arrows to highlight the waveform segment that you want to scale. Then press **Load Segment From NVARB Memory** to load the segment to the volatile ARB waveform memory (ARBI). The following figure shows the display after loading the segment, 5-TONE-A, into volatile ARB memory.

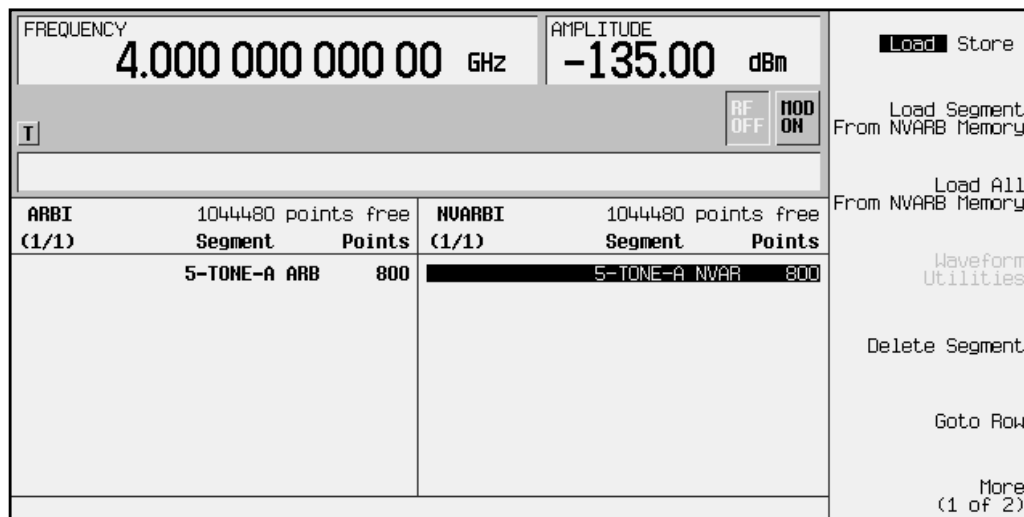

- Press **Load Store** so that Store is selected. If more than one waveform segment is present in the volatile ARB waveform memory (ARB), use the directional arrows to highlight the waveform segment that you want to scale. Press **Waveform Utilities > Set Scaling**.
- Press the **Scaling 100.00%** softkey. Use the numeric keypad to enter **5, 0**. Then press the **% terminator** softkey. The scaling softkey now reads **Scaling 50.00%**, as shown in the following figure.

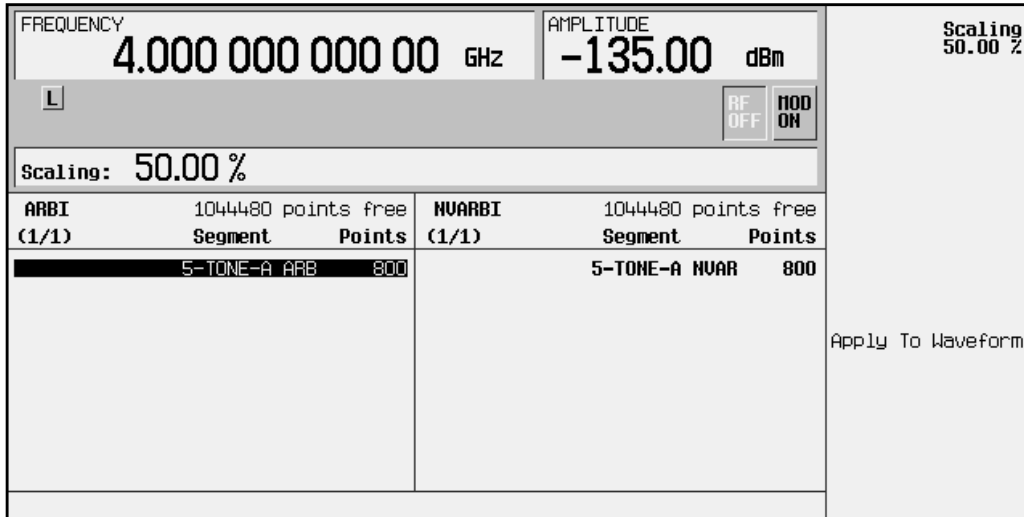

- Press the **Apply To Waveform** softkey to scale the waveform segment to 50% and return to the previous menu, as shown in the following figure.

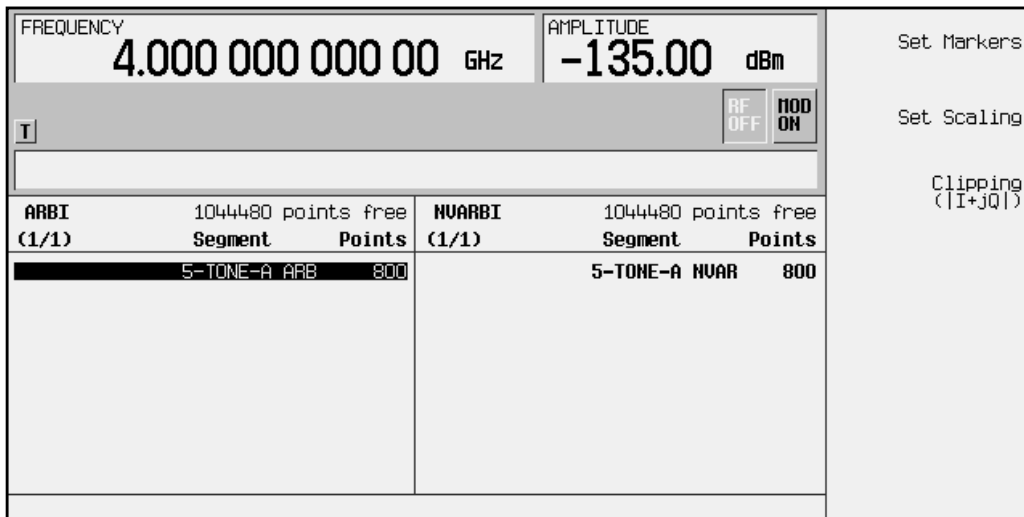

Clipping Waveform Segments

Clipping limits power peaks in waveform segments by clipping the composite I/Q waveform (or I and Q separately) to a selected percentage of its highest peak. Clipping can be set from 10 to 100% in 0.01% increments. You must select a waveform segment in the volatile ARB waveform memory before it can be clipped. For more information, refer to “Understanding Baseband Clipping” on page 4-10.

Perform the following procedure to configure and apply clipping to a waveform segment.

1. Press the **Mode** key.
2. Press **Arb Waveform Generator** (if it appears). Then press **Dual ARB > Waveform Segments**.
3. If you want to clip a waveform segment that is not in the volatile ARB waveform memory, press **Load Store** so that **Load** is selected. If more than one waveform segment is present in the non-volatile ARB waveform memory (NVARBI), use the directional arrows to highlight the waveform segment that you want to scale. Then press **Load Segment From NVARB Memory** to load the segment to the volatile ARB waveform memory (ARBI). The following figure shows the display after loading the segment, 5-TONE-A, into volatile ARB memory.

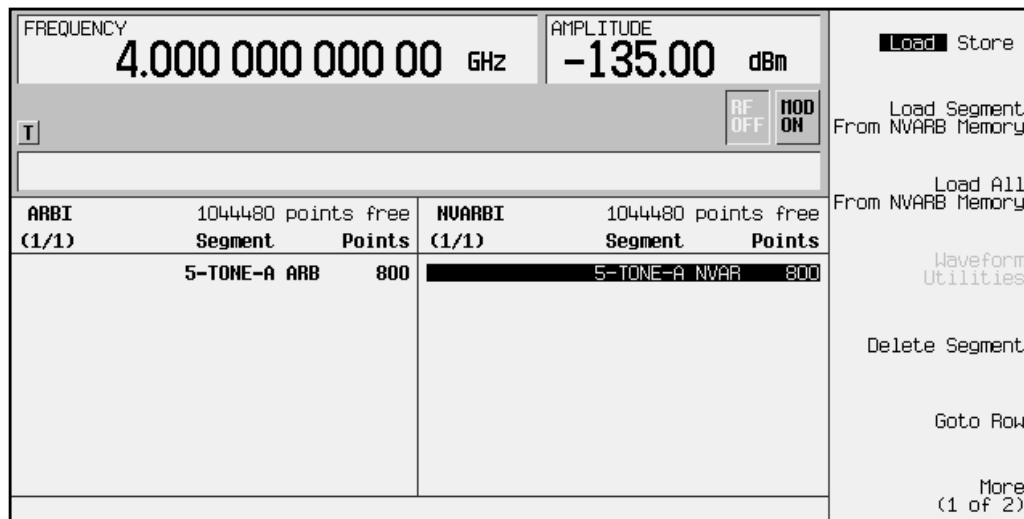

4. Press **Load Store** so that **Store** is selected. If more than one waveform segment is present in the volatile ARB waveform memory (ARBI), use the directional arrows to highlight the waveform segment that you want to clip. Press **Waveform Utilities > Clipping** to access the clipping setup menu.
5. Notice that the **Clipping Type** $|I+jQ|$ $||,|Q|$ softkey default is $|I+jQ|$ (*circular clipping*). This selection clips the combined I and Q waveform. Alternatively, $||,|Q|$ (*rectangular clipping*) clips the I and Q waveforms separately. Use the default selection for this example.

6. Press **Clip |I+jQ| To** and enter 80 percent. Notice that 80.0% is shown below the **Clip |I+jQ| To** softkey, as shown in the following figure.

FREQUENCY 4.000 000 000 00 GHz		AMPLITUDE -135.00 dBm		Clipping Type I+jQ
T		RF OFF MOD ON		
Clip I+jQ To 80.0 %		Clip I To (N/A)		Clip Q To (N/A)
Apply To Waveform				
ARBI (1/1)	1044480 points free Segment Points	NVARBI (1/1)	1044480 points free Segment Points	
	5-TONE-A ARB 800		5-TONE-A NVAR 800	

7. Press the **Apply To Waveform** softkey to clip the waveform segment to 80% and return to the previous menu, as shown in the following figure.

FREQUENCY 4.000 000 000 00 GHz		AMPLITUDE -135.00 dBm		Set Markers▶
T		RF OFF MOD ON		
Set Scaling▶		Clipping (I+jQ)▶		
ARBI (1/1)	1044480 points free Segment Points	NVARBI (1/1)	1044480 points free Segment Points	
	5-TONE-A ARB 800		5-TONE-A NVAR 800	

Downloading Waveform Files Into Memory

Follow the guidelines in this section to learn how to download waveform files into the signal generator's ARB memory. (Option UND is required.) For information on system interface, including GPIB and RS-232, refer to the programming guide.

Downloading Waveform Files Into ARB Memory

Downloading waveforms into volatile (ARB) memory is much quicker than downloading waveforms into non-volatile (NVARB) memory. If you want to store waveforms in NVARB memory, first follow the instructions to download into volatile ARB memory and then copy or move the waveforms internally into NVARB memory. See the following section titled, "[Transferring Waveforms Between ARB and NVARB Memory.](#)"

Use the following SCPI command lines to download a waveform to ARB memory:

```
MMEM:DATA "ARBI:<waveform_name>",<I_waveform_data>
```

This command downloads the I values for your waveform. The variable <waveform_name> denotes the name that will be associated with the downloaded waveform data within the signal generator and therefore must be the same for both I and Q downloads.

```
MMEM:DATA "ARBQ:<waveform_name>",<Q_waveform_data>
```

This command downloads the Q values for your waveform.

The signal generator will associate the I waveform values and the Q waveform values, and drive the I and Q modulators with the stored waveform in the baseband generator. If only one of the two required commands is executed (I values only or Q values only), the missing data will be set to values corresponding to a 0 V output.

Sample Command Line

A sample command line:

```
MMEM:DATA "ARBI:<waveform_name>",#ABC
```

"<waveform_name>" the name of the waveform file within the signal generator

- A the number of decimal digits to follow in B.
- B a decimal number specifying the number of data bytes in C.
- C the binary waveform data in 2-byte integers.

Example 1

```
MMEM:DATA "ARBI:WAVEFORM1" > #232<32 bytes of data>
```

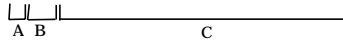

WAVEFORM1 the waveform name

2 defines the number of decimal digits to follow in B. This variable is represented by A in the sample command line.

32 denotes how many bytes of data are to follow. This variable is represented by B in the sample command line.

<32 bytes
of data> the binary waveform data in 2-byte integers. Data order is defined as Most Significant Bit (first) through Least Significant Bit (last). This variable is represented by C in the sample command line.

Querying the Waveform Data

Use the following SCPI command line to upload waveform data from the ARB memory to the personal computer:

```
MMEM:DATA? "ARBI:<waveform_name>"
MMEM:DATA? "ARBQ:<waveform_name>"
```

Waveform Downloading Using BASIC for Windows™

The following program shows you how to use download waveforms using BASIC for Windows™.

First, the I waveform data is put into an array of integers called `Iwfm_data` and the Q waveform data is put into an array of integers called `Qwfm_data`. The variable `Nbytes` is set to equal the number of bytes in the I waveform data. This should be twice the number of integers in `Iwfm_data`, since an integer is 2 bytes. Input integers must be between 0 and 16383.

In the Output commands, the USING "#,K" formats the data. The pound symbol (#) suppresses the automatic EOL (End of Line) output. This allows multiple output commands to be concatenated as if they were a single output. The "K" instructs BASIC to output the following numbers or strings in the default format.

```
5 Npoints=20
10 ALLOCATE INTEGER Iwfm_data(1:Npoints),Qwfm_data(1:Npoints)
15 DEG
20 FOR I=1 TO Npoints
25 Iwfm_data(I)=INT(8191*(COS(I*360/Npoints))+8192)
30 Qwfm_data(I)=INT(8191*(COS(I*360/Npoints))+8192)
35 NEXT I
40 Nbytes=2*Npoints
45 Assign @ESG to 719
50 Assign @ESGb to 719; FORMAT MSB FIRST
60 Nbytes$=VAL$(Nbytes)
70 Ndigits$=VAL$(LEN$(Nbytes$))
80 OUTPUT @ESG USING "#,K";"MMEM:DATA "ARBI:testfile", #
90 OUTPUT @ESG USING "#,K";Ndigits$
```



```

100 OUTPUT @ESG USING "#,K";Nbytes
110 OUTPUT @ESGb;Iwfm_data(*)
120 OUTPUT @ESG;
130 OUTPUT @ESG USING "#,K";"MMEM:DATA "ARBQ:testfile", #"
140 OUTPUT @ESG USING "#,K";Ndigits$
150 OUTPUT @ESG USING "#,K";Nbytes$
160 OUTPUT @ESGb;Qwfm_data(*)
170 OUTPUT @ESG;
180 Assign @ESG TO *
190 Assign @ESGb to *
200 END
    
```

Table 2-1

5:	Sets the number of points in the waveform.
10:	Defines arrays for I and Q waveform points. Sets them to be integer arrays.
15:	Sets BASIC to use degrees for cosine and sine functions.
20:	Sets up loop to calculate waveform points.
25:	Calculates I waveform points.
30:	Calculates Q waveform points.
35:	End of loop.
40:	Calculates number of bytes in I or Q waveform.
45:	Opens an I/O path to the signal generator using GPIB. 7 is the address of the GPIB card in the computer > and 19 is the address of the signal generator. This I/O path is used to send ASCII data to the signal generator.
50:	Opens an I/O path for sending binary data to the signal generator. <code>FORMAT MSB FIRST</code> is needed to send the 2 bytes of each integer to the signal generator in the correct order.
60:	Creates an ASCII string representation of the number of bytes in the waveform.
70:	Finds the number of digits in Nbytes.
80:	Sends the I waveform SCPI download-to-ARBI command and the beginning of the ASCII header for the data. <code>testfile</code> is the waveform name that will be used in the signal generator.
90 to 100:	Sends the rest of the ASCII header.
110:	Sends the binary data. Note that <code>ESGb</code> is the binary I/O path.
120:	Sends an End-of-Line to terminate the transmission.
130 to 170:	Executes same commands for the Q waveform.
180 to 190:	Closes the connections to the signal generator.
200:	End the program.

Waveform Downloading HP BASIC for UNIX

The following program shows you how to download waveforms using HP BASIC UNIX.

First, the I waveform data is put into an array of integers called `Iwfm_data` and the Q waveform data is put into an array of integers called `Qwfm_data`. The variable `Nbytes` is set to equal the number of bytes in the I waveform data. This should be twice the number of integers in `Iwfm_data`, since an integer is 2 bytes. Input integers must be between 0 and 16383.

In the Output commands, USING "#,K" formats the data. The pound symbol (#) suppresses the automatic EOL (End of Line) output. This allows multiple output commands to be concatenated as if they were a single output. The "K" instructs BASIC to output the following numbers or strings in the default format.

```
5 Npoints=20
10 ALLOCATE INTEGER Iwfm_data(1:Npoint),Qwfm_data(1:Npoints)
15 DEG
20 FOR I=1 TO Npoints
25   Iwfm_data(I)=INT(8191*(COS(I*360/Npoints))+8192)
30   Qwfm_data(I)=INT(8191*(COS(I*360/Npoints))+8192)
35 NEXT I
40 Nbytes=2*Npoints
45 Assign @ESG to 719;FORMAT ON
50 Assign @ESGb to 719; FORMAT OFF
55 Nbytes$=VAL$(Nbytes)
60 Ndigits$=(LEN$(Nbytes$))
65 OUTPUT @ESG USING "#,K";"MMEM:DATA " "ARBI:<name>"",#"
70 OUTPUT @ESG USING "#,K";Ndigits$
75 OUTPUT @ESG USING "#,K";Nbytes
80 OUTPUT @ESGb;Iwfm_data(*)
85 OUTPUT @ESG;
90 OUTPUT @ESG USING "#,K";"MMEM:DATA " "ARBQ:<name>"",#"
95 OUTPUT @ESG USING "#,K";Ndigits$
100 OUTPUT @ESG USING "#,K";Nbytes
105 OUTPUT @ESGb;Qwfm_data(*)
110 OUTPUT @ESG;" ";
115 Assign @ESGb to *
120 Assign @ESG to *
125 END
```

Table 2-2

5:	Sets the number of points in the waveform.
10:	Defines arrays for I and Q waveform points. Sets them to be integer arrays.
15:	Sets BASIC to use degrees for cosine and sine functions.
20:	Sets up loop to calculate waveform points.
25:	Calculates I waveform points.
30:	Calculates Q waveform points.
35:	End of loop.
40:	Calculates number of bytes in I or Q waveform.
45:	Opens an I/O path to the signal generator using GPIB. 7 is the address of the GPIB card in the computer, and 19 is the address of the signal generator. This I/O path is used to send ASCII data to the signal generator.
50:	Opens an I/O path for sending binary data to the signal generator.
55:	Creates an ASCII string representation of the number of bytes in the waveform.
60:	Finds the number of digits in Nbytes.
65:	Sends the I waveform SCPI download-to-ARBI command and the beginning of the ASCII header for the data. The variable <name> is the waveform name that will be used in the signal generator.
70 to 75:	Sends the rest of the ASCII header.
80:	Sends the binary data. Note that ESGb is the binary I/O path.
85:	Sends an End-of-Line to terminate the transmission.
90 to 110:	Executes same commands for the Q waveform. The variable <name> that appears in program line 100 must be identical to that in program line 50.
115 to 120:	Closes the connections to the signal generator.
125:	End the program.

Transferring Waveforms Between ARB and NVARB Memory

Use one of the following procedures to transfer waveforms between ARB and NVARB memory. You can use either remote commands via GPIB, or the front panel keys. As mentioned earlier, it is much faster to first download waveforms to ARB memory and then transfer them to NVARB memory.

Copying Waveforms From ARB to NVARB Memory

To copy waveforms from ARB to NVARB memory, execute the following command lines:

```
MMEM: COPY "ARBI:<waveform_name>" , "NVARBI:<waveform_name>"  
MMEM: COPY "ARBQ:<waveform_name>" , "NVARBQ:<waveform_name>"
```

Or **Mode > ARB Waveform Generator** (if it appears) > **Dual ARB > Waveform Segments >** (highlight the waveform in ARB memory that you want to copy) **Store Segment To NVARB Memory**.

Copying Waveforms From NVARB to ARB Memory

To copy waveforms from NVARB to ARB memory, execute the following command lines:

```
MMEM: COPY "NVARBI:<waveform_name>" , "ARBI:<waveform_name>"  
MMEM: COPY "NVARBQ:<waveform_name>" , "ARBQ:<waveform_name>"
```

Or **Mode > ARB Waveform Generator** (if it appears) > **Dual ARB > Waveform Segments > Load >** (highlight the waveform in NVARB memory that you want to copy) **Load Segment From NVARB Memory**.

Selecting a Waveform and Activating the Modulation via GPIB

The following remote commands are used to select a waveform and activate the modulation.

```
:RADio:ARB:WAVeform "ARBI:"<waveform_name>" "
```

This command selects the waveform called <waveform_name> in ARB memory as the modulation for the signal generator's RF output.

```
:RADio:ARB:WAVeform "SEQ:"<sequence_name>" "
```

This command selects the user-defined sequence from the signal generator's catalog memory as the modulation at the signal generator's RF output.

```
:RADio:ARB ON
```

This command drives the I and Q modulators with the chosen waveform/sequence in the baseband generator.

NOTE If you attempt to stop sending information to the signal generator during the execution of a remote command that is sending waveform data, the signal generator will wait indefinitely for further input.

If this happens, you should execute the appropriate device clear command for your programming language over GPIB.

As an example, in BASIC this command is `CLEAR 719` (assuming the signal generator's GPIB address has been set to 19).

This infinite loop may also happen if an interrupt occurs while trying to read (upload) data from the signal generator. During an interrupted upload, the device clear command can take up to three minutes to execute after the command is initially sent.

Viewing Files Stored in the Memory Catalog

The memory catalog can be used to view the existing waveform files, sequence files, CDMA files, and FIR files that have been transferred to the source's mass memory. To review the memory catalog by file type:

1. If the signal generator is in remote mode, first press the **Local** key to return the signal generator to local control. Press **Utility** (located in the **MENUS** section of the signal generator's front panel).
2. Press **Memory Catalog**.
3. Press **Catalog Type**. If you do not wish to review the FIR catalog, continue with step 5.

To view the files in the FIR catalog, press **FIR**. You can use the appropriate softkeys in this menu to copy, rename, and delete specific files, or to delete all the files within the FIR directory. When you are finished, press **Catalog Type**.

4. To view arbitrary waveform generator-related files, press **ARB Catalog Types**.
 - Press **Seq** to review all of the files in the sequence catalog. Sequence files hold information such as waveform file names, number of repetitions, and playing order.
 - Press **ARB** to review all of the existing arbitrary waveform generator waveform files in volatile ARB memory.
 - Press **NVARB** to review all of the existing arbitrary waveform generator waveform files in NVARB memory.
 - Press **CDMA** to review all of the files in the CDMA catalog.
 - Press **MCDMA** to review all of the files in the multicarrier CDMA catalog.
 - Press **MTONE** to review all of the files in the multitone catalog.

For all arbitrary waveform generator catalog types, you can use the appropriate softkeys to rename or delete specific files, or delete all of the files present in a specific catalog directory. In addition, the Sequence and CDMA directories contain a **Copy File** softkey that allows you to copy and rename a specific file.

You can also view the waveform files in ARB and NVARB memory by pressing **Mode > ARB Waveform Generator** (if it appears) **> Dual ARB > Waveform Segments**.

Creating Additive White Gaussian Noise (AWGN) Waveforms

Using this procedure, you will create an additive white gaussian noise waveform with a bandwidth of 1.25 MHz, a waveform length of 131072 points, and a random noise seed.

The signal generator provides a quick and easy solution to creating additive white gaussian noise waveforms. Waveform bandwidth, length, and noise seed can be adjusted to fit your particular requirements. (Options UND and UN5 are both required.)

1. Press **Preset** to return the signal generator to normal preset conditions.
2. Press the front panel **Mode** key. (If you have multiple options and the **Arb Waveform Generator** softkey is visible, press it next.) Press **AWGN**.
3. Press **Bandwidth**. Using the numeric keypad, enter 1.25 and press the **MHz** terminator. The noise bandwidth is now set to 1.25 MHz.
4. Press **Waveform Length > 131072**. The waveform's length is now set to 131072 points.
5. Press **Noise Seed Fixed Random** until **Random** highlights. The data generating the noise seed is now set to random.
6. Press **AWGN Off On** until **On** highlights. The front panel **AWGN** and **I/Q** annunciators appears, and the waveform builds.

Using Arbitrary Waveform Generator Triggers

The arbitrary waveform generator includes several different triggering options. For information on the triggering capabilities of the signal generator, see [“Understanding Arbitrary Waveform Generator Triggers”](#) on page 4-8.

NOTE Dual ARB triggers and their associated softkeys and SCPI functionality became available in signal generators with serial number prefix US3844 or GB3845. Dual ARB triggers are *not* available in signal generators with an earlier serial number prefix, unless upgraded.

To upgrade your signal generator to include Dual ARB triggering, contact your nearest Agilent Technologies Sales and Service office.

In the following procedures, you will learn how to create a time-delayed, externally triggered custom multicarrier CDMA waveform ([“Creating an Externally Triggered Custom Multicarrier CDMA Waveform”](#) on page 2-81) and how to use segment advance triggering with waveform sequences ([“Controlling Waveform Sequence Playback Using Segment Advance Triggering”](#) on page 2-86).

Creating an Externally Triggered Custom Multicarrier CDMA Waveform

Using this procedure, you will recall a custom multicarrier CDMA state from the signal generator’s MCDMA memory catalog and single-trigger the waveform externally with a 100 msec delay.

For this example, recall `5CARRIER`, the custom 5-carrier CDMA waveform created in the procedure titled, [“Creating Custom Multicarrier CDMA Waveforms”](#) on page 2-15 and stored using the procedure titled, [“Storing a Custom Multicarrier CDMA Waveform”](#) on page 2-23. If you have not created and stored a custom multicarrier CDMA waveform, refer to these previous sections. (Options UND and UN5 are both required.)

Required Equipment

HP/Agilent 33120A Function Generator

1. Connect the signal generator to the function generator as shown in the following figure.

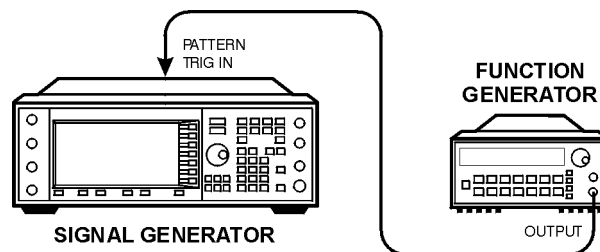

pk719b

2. Press **Preset** to return the signal generator to normal preset conditions.
3. Press the front panel **Mode** key. If you have multiple options and the **Arb Waveform Generator** softkey is visible, press it next. Press **CDMA Formats > IS-95A**. Then press **Multicarrier Off On** until **On** is highlighted, as shown in the following figure.

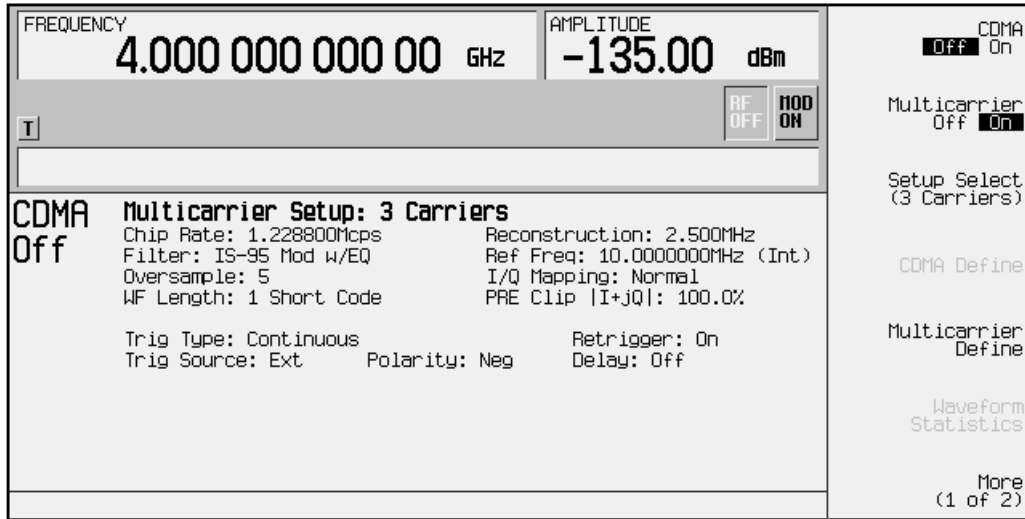

4. Press **Setup Select**. The default multicarrier CDMA template is set to **3 Carriers**. Press **Custom CDMA Multicarrier** to open the MCDMA memory catalog, as shown in the following figure.

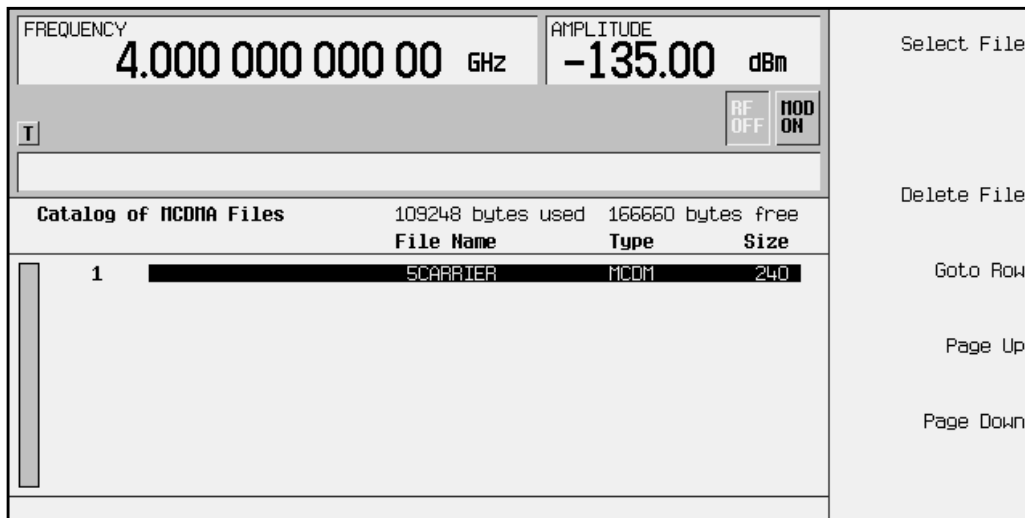

- Use the front panel knob or the arrow keys to highlight the file 5CARRIER, then press **Select File**. The custom multicarrier CDMA waveform 5CARRIER is selected, as shown in the following figure.

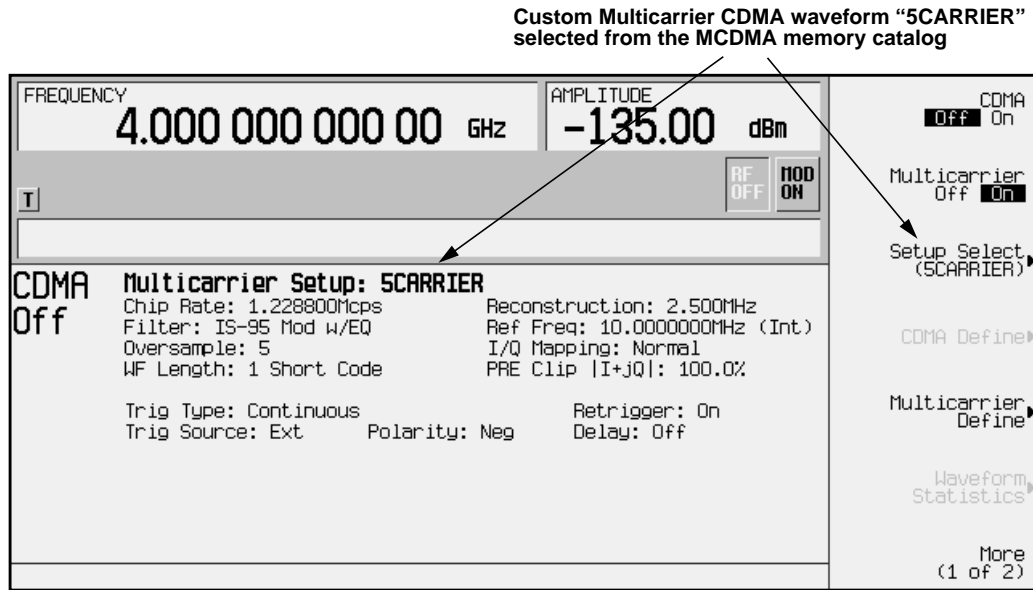

- To set the trigger type to Single, press **More (1 of 2) > Trigger > Single** as shown in the following figure. The waveform will now trigger once when it receives the appropriate signal from the trigger source.

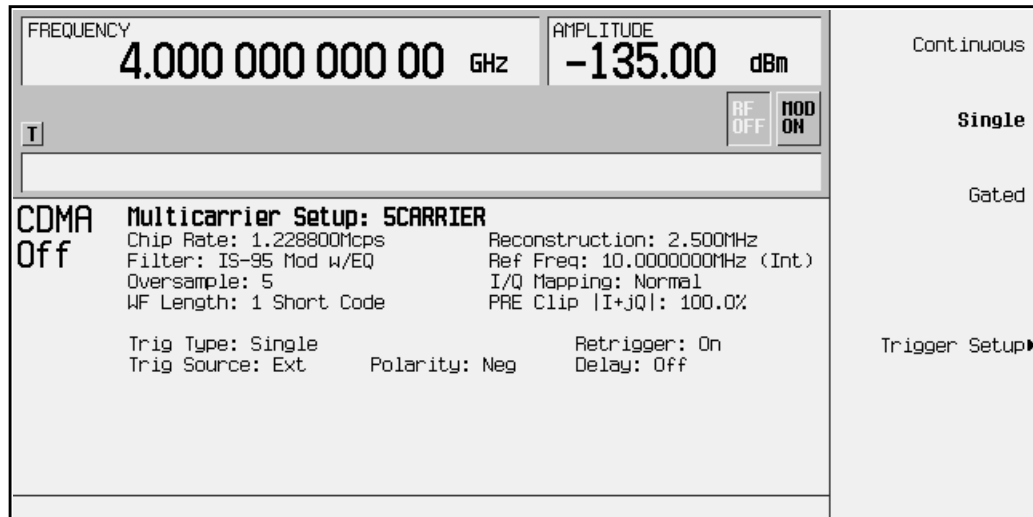

- To set the trigger source to External, press **Trigger Setup > Trigger Source > Ext** as shown in the following figure. The waveform will now trigger when it detects a change in TTL state at the PATTERN TRIG IN rear panel connector.

FREQUENCY 4.000 000 000 00 GHz		AMPLITUDE -135.00 dBm		Trigger Key
<input type="checkbox"/> T		<input type="checkbox"/> RF OFF <input checked="" type="checkbox"/> MOD ON		Bus
CDMA Off				Ext
Multicarrier Setup: SCARRIER Chip Rate: 1.228800Mcps Reconstruction: 2.500MHz Filter: IS-95 Mod w/EQ Ref Freq: 10.000000MHz (Int) Oversample: 5 I/Q Mapping: Normal WF Length: 1 Short Code PRE Clip I+jQ : 100.0%				Ext Polarity <input checked="" type="checkbox"/> Neg <input type="checkbox"/> Pos
Trig Type: Single Retrigger: On Trig Source: Ext Delay: Off Polarity: Neg				Ext Delay <input checked="" type="checkbox"/> Off <input type="checkbox"/> On
				Ext Delay Time 2.000 msec

- To set the external polarity to Positive, press **Ext Polarity Neg Pos** until **Pos** is highlighted, as shown in the following figure. The waveform will now trigger when it detects a change in TTL state from low to high at the PATTERN TRIG IN rear panel connector.

FREQUENCY 4.000 000 000 00 GHz		AMPLITUDE -135.00 dBm		Trigger Key
<input type="checkbox"/> T		<input type="checkbox"/> RF OFF <input checked="" type="checkbox"/> MOD ON		Bus
CDMA Off				Ext
Multicarrier Setup: SCARRIER Chip Rate: 1.228800Mcps Reconstruction: 2.500MHz Filter: IS-95 Mod w/EQ Ref Freq: 10.000000MHz (Int) Oversample: 5 I/Q Mapping: Normal WF Length: 1 Short Code PRE Clip I+jQ : 100.0%				Ext Polarity <input type="checkbox"/> Neg <input checked="" type="checkbox"/> Pos
Trig Type: Single Retrigger: On Trig Source: Ext Delay: Off Polarity: Pos				Ext Delay <input checked="" type="checkbox"/> Off <input type="checkbox"/> On
				Ext Delay Time 2.000 msec

9. To activate the external delay, press **Ext Delay Off On** until **On** is highlighted, as shown in the following figure. The waveform will now trigger after the defined delay time.

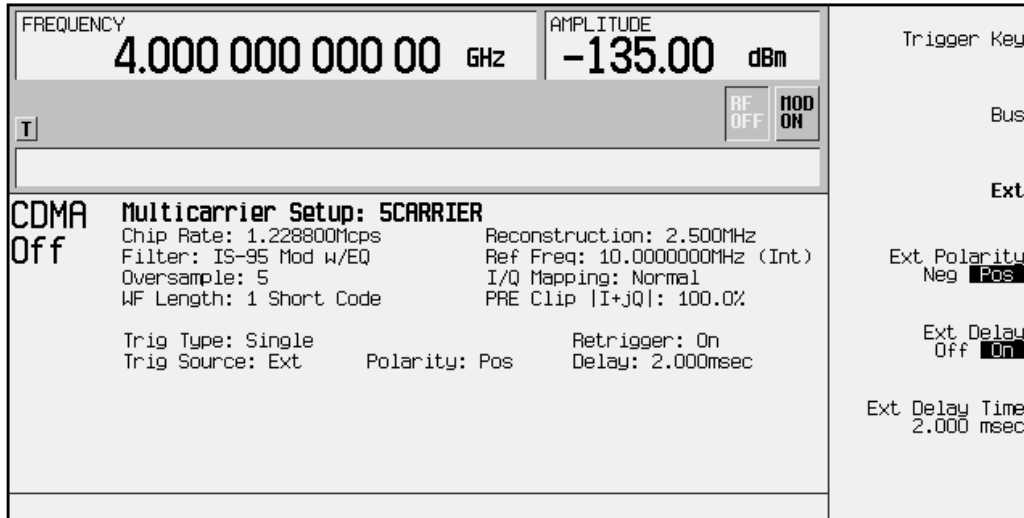

10. To set the external delay time, press **Ext Delay Time**. Using the numeric keypad, enter 100 and terminate your entry with the **msec** softkey, as shown in the following figure. The waveform will now trigger after a 100 msec delay time.



11. Set the function generator to output a 0.1 Hz square wave at an output level of 0 to 5V.

12. To activate the recalled custom multicarrier CDMA waveform, press **Mode**, (if you have multiple options, press **Arb Waveform Generator**) > **CDMA Formats** > **IS-95A** > **CDMA Off On** to **On**. The firmware generates the custom multicarrier CDMA waveform in ARB memory. After waveform generation, the custom multicarrier CDMA state is available to be modulated on the RF output.

13. At signal generator preset, **Mod On/Off** is set to **On**. If you did not start this procedure by presetting the signal generator, press **Mod On/Off** to **On**.

NOTE The RF output amplitude and frequency settings are not saved as part of a custom multicarrier CDMA state file. At signal generator preset (or line power cycle), the RF output frequency is reset to the signal generator's highest specified value and the RF output amplitude is reset to -135 dBm. Before activating the RF output, make adjustments to the RF output frequency and amplitude as required.

14. To activate the RF output, press RF On/Off to On.

Controlling Waveform Sequence Playback Using Segment Advance Triggering

Using this procedure, you will create and store a 5-tone multitone waveform segment, create and store another 5-tone multitone waveform with modifications, create a sequence containing both waveform segments, and control the sequence playback using segment advance triggering.

1. Press **Preset** to return the signal generator to normal preset conditions.
2. Press the front panel **Mode** key. If you have multiple options and the **Arb Waveform Generator** softkey is visible, press it next. Press **Multitone > Initialize Table > Number of Tones**. Using the numeric keypad, press 5 and terminate your entry with the **Enter** softkey. Modify the frequency spacing to 100 kHz by pressing **Freq Spacing** and using the numeric keypad to enter 100. Terminate your entry with the **kHz** softkey and press **Done**. To generate the multitone waveform in ARB memory, press **Multitone Off On** until **On** is highlighted. You now have a 5-tone multitone waveform, as shown in the following figure.

Tone	Freq Offset	Power	Phase	State
1	-200.000 kHz	0.00 dB	0	On
2	-100.000 kHz	0.00 dB	0	On
3	0.000 kHz	0.00 dB	0	On
4	100.000 kHz	0.00 dB	0	On
5	200.000 kHz	0.00 dB	0	On

NOTE At this point, the multitone waveform has the default name assigned to all ARB-generated waveforms: `AUTOGEN_WAVEFORM`. Follow the instructions in the next step to rename the waveform.

- Press the front panel **Mode** key. If you have multiple options and the **Arb Waveform Generator** softkey is visible, press it next. Press **Dual ARB > Waveform Segments >** (highlight the **AUTOGEN_WAVEFORM** segment) **More (1 of 2) > Rename Segment > Editing Keys > Clear Text**. Using the file naming softkeys, name the file **5-TONE-A** and terminate your entry with the **Enter** softkey. You now have the multitone waveform **5-TONE-A** in ARB memory, as shown in the following figure.

FREQUENCY 4.000 000 000 00 GHz		AMPLITUDE -135.00 dBm	
T		I/Q	
RF OFF		MOD ON	
ARBI (1/1)	1044480 points free	NVARBI (1/1)	1048576 points free
Segment	Points	Segment	Points
5-TONE-A ARB	800		

NOTE The following step, 4. *Store the 5-TONE-A waveform to NVARB memory*, is not necessary, though it is good practice to store waveforms to non-volatile ARB (NVARB) memory to ensure that they are not erased if the signal generator’s line power is cycled.

- To store the **5-TONE-A** waveform to NVARB memory, press **More (2 of 2) > Store Segment To NVARB Memory**. The **5-TONE-A** waveform has now been copied to NVARB memory, as shown in the following figure.

FREQUENCY 4.000 000 000 00 GHz		AMPLITUDE -135.00 dBm	
T		I/Q	
RF OFF		MOD ON	
ARBI (1/1)	1044480 points free	NVARBI (1/1)	1044480 points free
Segment	Points	Segment	Points
5-TONE-A ARB	800	5-TONE-A NVAR	800

- Press the front panel **Mode** key. If you have multiple options and the **Arb Waveform Generator** softkey is visible, press it next. Press **Multitone**. Using the arrow keys or the front panel knob, highlight the **State** entry of the number 2 tone and press **Toggle State**. This turns off the number 2 tone. Using the arrow keys or the front panel knob, highlight the **State** entry of the number 4 tone and press **Toggle State**. This turns off the number 4 tone. Press **Apply Multitone**. (Because **Multitone Off On** is still set to **On**, this regenerates the multitone waveform using the changes made to the existing multitone waveform and stores it in ARB memory under the file name `AUTOGEN_WAVEFORM`.) You now have a 5-tone multitone waveform with tone 2 and tone 4 set to **Off**, as shown in the following figure.

The screenshot shows the Multitone Setup screen. At the top, the frequency is 4.000 000 000 00 GHz and the amplitude is -135.00 dBm. Below this, there are buttons for 'n-TONE', 'I/Q', 'RF OFF', and 'MOD ON'. The main part of the screen is a table titled 'Multitone Setup: default (UNSTORED)'. The table has columns for Tone, Freq Offset, Power, Phase, and State. The State column shows 'On' for tones 1, 3, and 5, and 'Off' for tones 2 and 4. To the right of the table, there are several softkeys: 'Multitone Off On', 'Initialize Table', 'Edit Item', 'Toggle State', 'Apply Multitone', and 'Goto Row'. At the bottom right, it says 'More (1 of 2)'.

Tone	Freq Offset	Power	Phase	State
1	-200.000 kHz	0.00 dB	0	On
2	-100.000 kHz	0.00 dB	0	Off
3	0.000 kHz	0.00 dB	0	On
4	100.000 kHz	0.00 dB	0	Off
5	200.000 kHz	0.00 dB	0	On

- Press the front panel **Mode** key. If you have multiple options and the **Arb Waveform Generator** softkey is visible, press it next. Press **Dual ARB > Waveform Segments**. Using the front panel knob or the arrow keys, highlight `AUTOGEN_WAVEFORM`, and press **More (1 of 2) > Rename Segment > Editing Keys > Clear Text**. Using the file naming

softkeys, name the file 5-TONE-B and terminate your entry with the Enter softkey. You now have the modified 5-tone waveform 5-TONE-B in ARB memory, as shown in the following figure.

FREQUENCY 4.000 000 000 00 GHz		AMPLITUDE -135.00 dBm		Rename Segment	
T		I/Q		Delete All ARB Files	
RF OFF		MOD ON		Waveform Statistics	
ARBBI (1/1) 1040384 points free		NVARBI (1/1) 1044480 points free			
Segment Points		Segment Points			
5-TONE-A ARB 800		5-TONE-A NVAR 800			
5-TONE-B ARB 800		5-TONE-B NVAR 800			
				More (2 of 2)	

NOTE The following step, 7. Store the 5-TONE-B waveform to NVARB memory, is not necessary, though it is good practice to store waveforms to non-volatile ARB (NVARB) memory to ensure that they are not erased if the signal generator's line power is cycled.

- To store the 5-TONE-B waveform to NVARB memory, press **More (2 of 2) >** **Store Segment To NVARB Memory**. The 5-TONE-B waveform has now been copied to NVARB memory, as shown in the following figure.

FREQUENCY 4.000 000 000 00 GHz		AMPLITUDE -135.00 dBm		Load Store	
L		I/Q		Store Segment To NVARB Memory	
RF OFF		MOD ON		Store All To NVARB Memory	
ARBBI (1/1) 1040384 points free		NVARBI (1/1) 1040384 points free		Waveform Utilities	
Segment Points		Segment Points		Delete Segment	
5-TONE-A ARB 800		5-TONE-A NVAR 800		Goto Row	
5-TONE-B ARB 800		5-TONE-B NVAR 800		More (1 of 2)	

- Press the front panel **Mode** key. If you have multiple options and the **Arb Waveform Generator** softkey is visible, press it next. Press **Dual ARB > Waveform Sequences > Build New Waveform Sequence > Insert Waveform**. Use the arrow keys or the front panel knob to highlight the **5-TONE-A** waveform segment. Press **Insert Selected Waveform**. This loads one repetition of the **5-TONE-A** waveform segment into the sequencer. Use the arrow keys or the front panel knob to highlight the **5-TONE-B** waveform segment. Press **Insert Selected Waveform**. This loads one repetition of the **5-TONE-B** waveform segment into the sequencer. Press **Done Inserting**. One repetition of the **5-TONE-B** waveform segment is now programmed to follow the **5-TONE-A** waveform segment in the sequence. Highlight the **5-TONE-A** waveform segment. Press **Edit Repetitions**. Using the numeric keypad, enter 1000 and press **Enter**. This programs the sequencer to play the **5-TONE-A** waveform segment 1000 times before playing the **5-TONE-B** waveform segment. Highlight the **5-TONE-B** waveform segment. Press **Edit Repetitions**. Using the numeric keypad, enter 1000 and press **Enter**.

This programs the sequencer to play the **5-TONE-B** waveform segment 1000 times before playing the **5-TONE-A** waveform segment again. You now have a sequence designed to play each waveform segment 1000 times, as shown in the following figure.

FREQUENCY 4.000 000 000 00 GHz		AMPLITUDE -135.00 dBm		Insert Waveform	
I/T		I/Q			Delete Selected Waveform
5-TONE		RF OFF		Delete All Waveforms	
		MOD ON		Edit Repetitions	
(1/1)	Segment	5-TONE-B Sequence	(UNSTORED) (1/1)	UNTITLED	Toggle Markers
	5-TONE-A		ARB:5-TONE-A 1000		Name And Store
	5-TONE-B		ARB:5-TONE-B 1000		Goto Row

- Press **Name and Store**. Use the file naming softkeys and the numeric keypad to name the sequence **5-TONE-AX1K+5-TONE-BX1K**. Terminate your entry by pressing **Enter**.

10. Press the front panel **Mode** key. If you have multiple options and the **Arb Waveform Generator** softkey is visible, press it next. Press **Dual ARB > Select Waveform**. Using the front panel knob or the arrow keys, highlight the sequence **5-TONE-AX1K+5-TONE-BX1K** and press **Select Waveform**. The sequence is now ready for playback, as shown in the following figure.

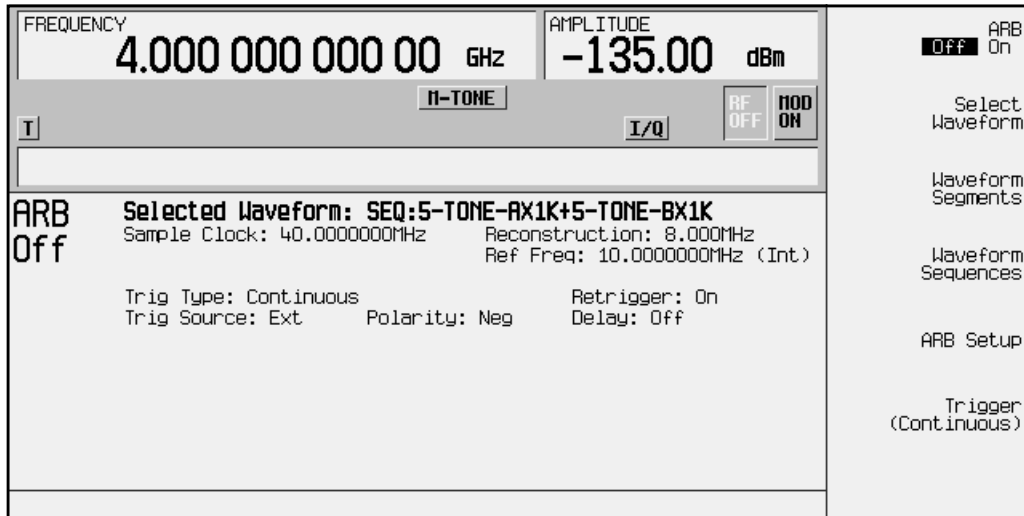

11. Press **Trigger > Segment Advance**. This will program the sequencer to stop the playback of the current waveform segment and start the playback of the next waveform segment in the sequence when a trigger is received from the trigger source, as shown in the following figure.

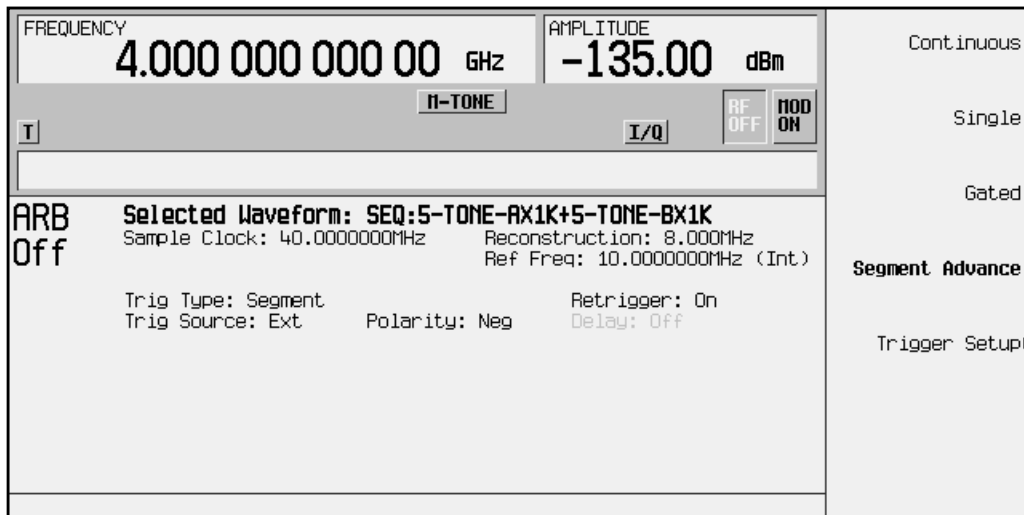

12. Press **Trigger Setup > Trigger Source > Trigger Key**. This will program the sequencer to stop the playback of the current waveform segment and start the playback of the next waveform segment in the sequence when the front panel **Trigger** hardkey is pressed, as shown in the following figure.

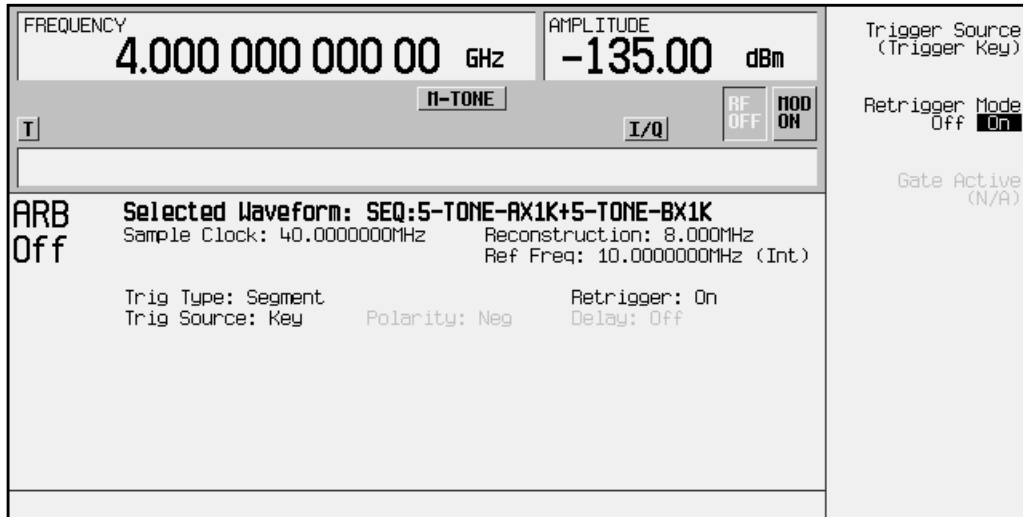

13. Press **Frequency** and enter the desired RF output frequency.
14. Press **Amplitude** and enter the desired RF output amplitude.
15. At signal generator preset, **Mod On/Off** is set to **On**. If you did not start this procedure by presetting the signal generator, press **Mod On/Off** to **On**.
16. Connect the signal analyzer's input to the output of the signal generator and adjust the display until you can comfortably observe the complete output of the signal generator's first waveform segment.
17. To activate the RF output, press **RF On/Off** to **On**.
18. Press the front panel **Mode** key. If you have multiple options and the **Arb Waveform Generator** softkey is visible, press it next. Press **Dual ARB**, then **ARB Off On** until **On** is highlighted. Observe the first waveform (5-TONE-A) in the sequence is now playing.
19. Press the front panel **Trigger** hardkey. Observe the second waveform segment in the sequence (5-TONE-B) is now playing. Continually pressing the front panel **Trigger** hardkey will cycle through the two waveform segments.

Setting Up a Bluetooth Signal

This procedure will show you how to quickly set up a sample Bluetooth packet and impairments that include additive white gaussian noise (AWGN).

Accessing the Bluetooth Setup Menu

1. Press **Preset**, then press **Mode > Arb Waveform Generator (if it appears) > Bluetooth**.

NOTE For this section, the frequency and amplitude are set to typical Bluetooth values.

2. Press **Frequency > 2.4 > GHz**, then press **Amplitude > 10 > dBm**.

The following figure shows a display of the Bluetooth menu.

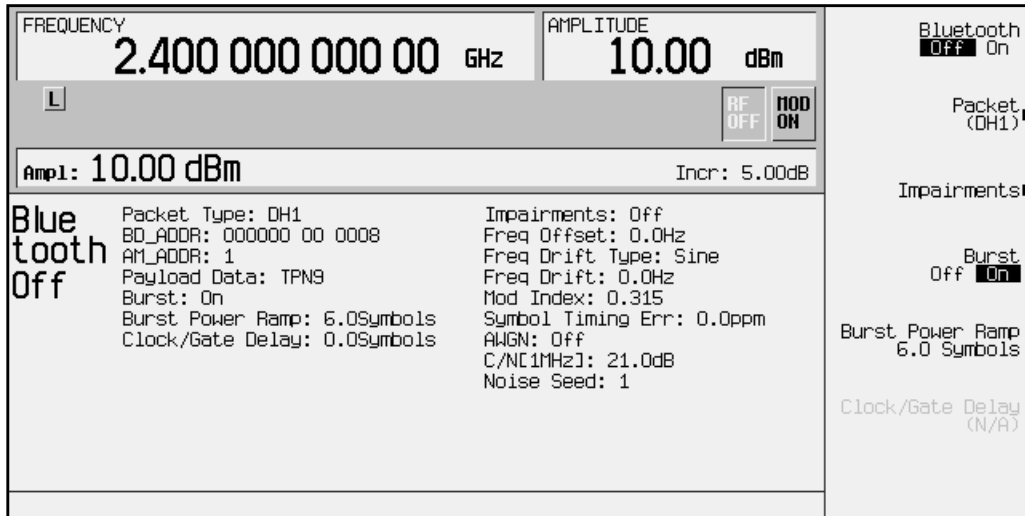

Setting Up Packet Parameters

The signal generator uses a DH1 (Data-High rate) packet for the Bluetooth format. The DH1 packet is a single bundle of information transmitted within a piconet and covers a single timeslot. This packet consists of 3 entities: the access code, the header, and the payload.

In the following example you will set the parameters of the DH1 packet.

1. Press **Packet (DH1)**.

This accesses a menu that enables you to set the packet parameters.

The following figure displays the packet menu.

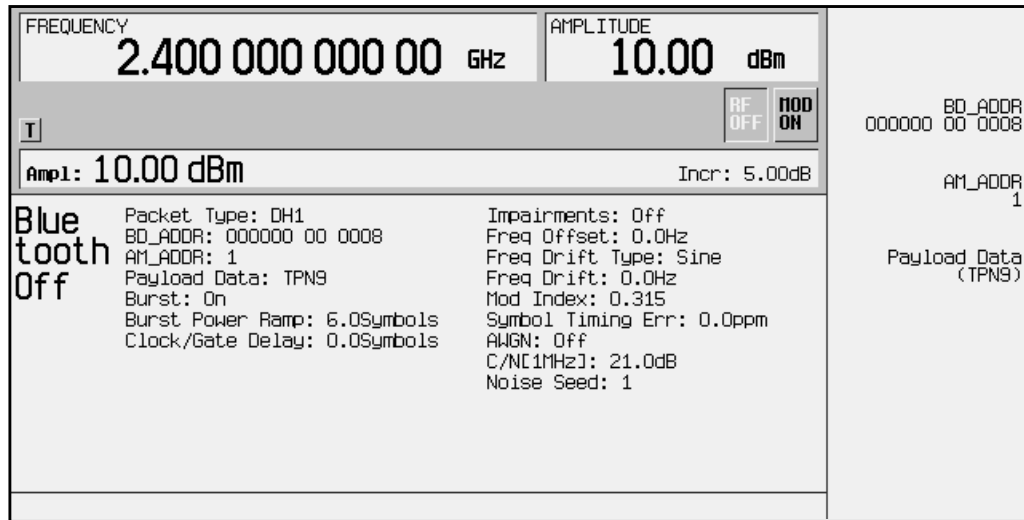

2. Press **BD_ADDR > 000000 00 1000 > Enter.**

This modifies the hexadecimal Bluetooth device address. Each Bluetooth transceiver is allocated a unique 48-bit Bluetooth device address. This address is derived from the IEEE802 standard.

For addresses with alpha characters, use the softkeys along with the keypad for data entry.

3. Press **AM_ADDR > 4 > Enter.**

This sets the active member address and is used to distinguish between the active members participating on the piconet.

NOTE The all-zero AM_ADDR is reserved for broadcast messages.

4. Press **Payload Data > 8 Bit Pattern > 10101010 > Enter.**

This selects a repeating 8-bit pattern as the payload data.

The following figure now displays the new packet parameters.

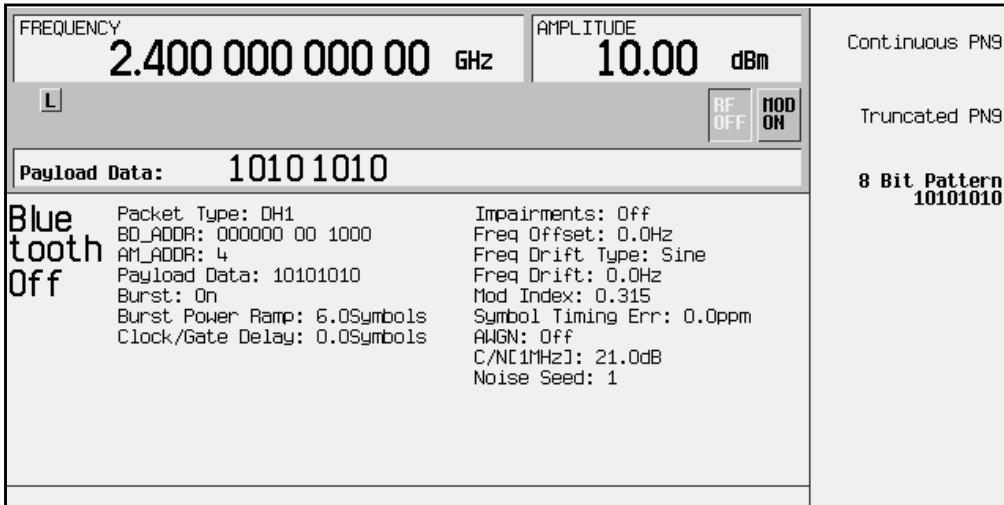

Setting up Impairments

In the following example you will set the parameters for the impairment function.

1. Press **Return** > **Return** > **Impairments**.

This accesses a menu which enables you to set up impairments.

2. Press **Freq Offset** > **25** > **kHz**.

3. Press **Freq Drift Type** **Linear Sine**.

This sets the frequency drift type to linear. Linear frequency drift will occur across a period of time equal to the duration of one fully loaded DH1 packet, regardless of the packet length. The default is the sine drift deviation which is plus or minus from the carrier center frequency.

4. Press **Drift Deviation** > **25** > **kHz**.

This sets the maximum deviation of the frequency drift of the carrier frequency.

5. Press **Mod Index** > **.325** > **Enter**.

Modulation index (similar to FM index) is defined as the frequency deviation divided by the modulation rate.

6. Press **Symbol Timing Err** > **1** > **ppm**.

This sets the symbol timing error in parts per million. The sample rate of the arbitrary waveform generator shifts to generate the symbol timing error.

7. Press **AWGN**.

This accesses a menu from which you can select the parameters of the AWGN to be applied as an impairment to the Bluetooth signal. The following parameters may be changed while AWGN is off, but will not be applied unless **AWGN** and **Impairments** are both turned On.

- a. Press **C/N [1MHz] > 20 > dB**.

This sets the carrier-to-noise ratio for a 1 MHz bandwidth.

- b. Press **Noise Seed > 2 > Enter**.

This sets the noise seed value used to assign a specific sequence of noise to be added to the basic Bluetooth signal. Different noise seeds generate different combinations of noise.

- c. Press **AWGN Off On**.

This turns the AWGN, as a Bluetooth impairment, on.

8. Press **Return > Impairments Off On**.

This returns you to the Impairments menu and turns the impairments function on.

The following figure displays the Impairments parameters.

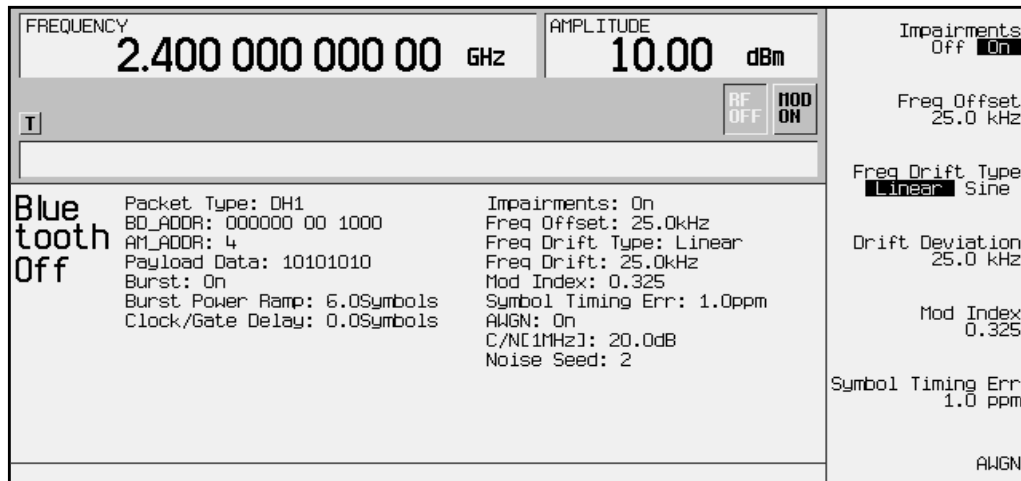

9. Press **Return**.

This returns you to the Bluetooth menu.

Using Burst

Burst in the **On** position will ramp up the power at the beginning and end of the transmitted packet. Burst off will transmit packets linked in a series with no power ramping. The default burst setting is **On**, but for troubleshooting you may want to turn bursting **Off**.

For this example Burst is left in the on position.

Setting the Burst Power Ramp

Press **Burst Power Ramp > 4 > Enter**.

This sets the duration of the power ramp to 4 symbols at beginning and end of the packet transmission.

Using Clock/Gate Delay

NOTE This function is available only when the payload data is continuous PN9 and is intended to be used during bit error rate (BER) testing.

1. Press **Packet (DH1) > Payload Data > Continuous PN9 > Return**.

This will enable you to specify the number of symbols to shift the clock and gate signals relative to the Bluetooth signal. For more information refer to [“Clock/Gate Delay”](#) on page 3-20.

2. Press **Clock/Gate Delay > 4 > Symbols**.

The Clock and Gate will be delayed 4 symbols to synchronize with the signal from the device under test (DUT).

Turning On a Bluetooth Signal

Press **Bluetooth** until **On** highlights.

This turns the operating state of the Bluetooth waveform generator **On**.

The front panel **I/Q** and **BLUETH** annunciators appear, and the waveform builds.

The following figure displays the Bluetooth waveform parameters.

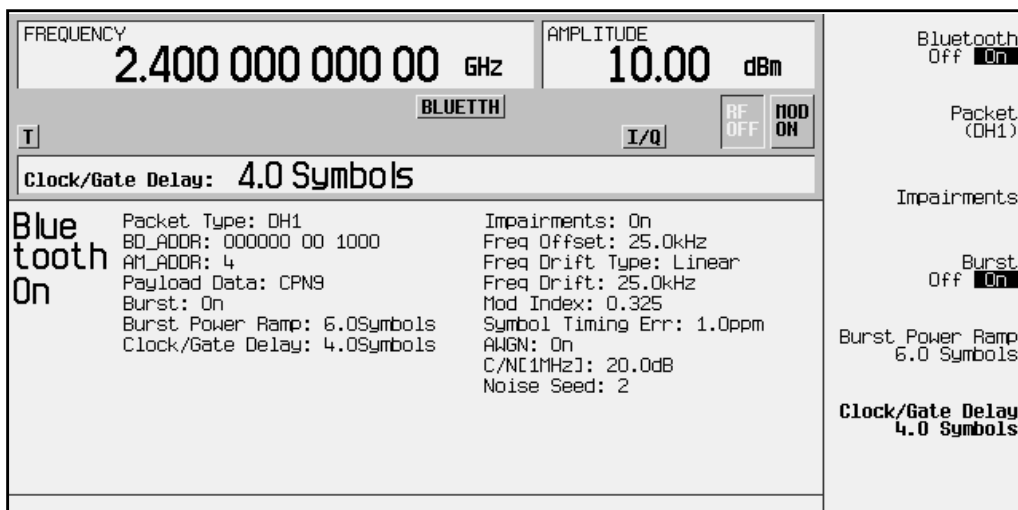

3 Softkey Reference

This chapter describes the **Mode** hardkey and the associated softkeys that are used to activate functions specific to the dual arbitrary waveform generator (Option UND) and the IS-95 CDMA personality (Option UN5).

For information on how to operate these functions remotely, see [Chapter 5, “Remote Programming.”](#)

Mode Key

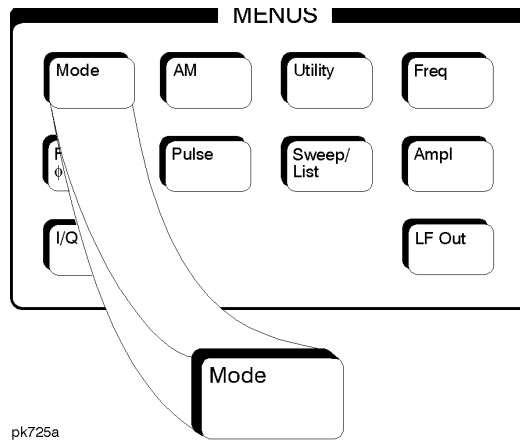

When you press the front-panel **Mode** key, the softkeys that appear depend on how many options are included in the signal generator. When a signal generator has multiple options, choose the **Arb Waveform Generator** softkey for access to all Dual Arbitrary Waveform Generator menus (including the optional personalities).

NOTE

The key paths provided in this chapter do not include the **Arb Waveform Generator** softkey; it is implied.

If you do not see a softkey in the indicated menu, it may be on the next page of that menu; to display the next page, press the **More** softkey.

Table 3-1 Dual Arbitrary Waveform Generator Softkeys

Softkey	Accesses	Option(s) Required
Dual ARB	Dual Arbitrary Waveform Generator	UND
CDMA Formats	All CDMA Waveform Generators listed below.	UND
IS-95A	Multichannel, Multicarrier IS-95A CDMA Waveform Generator	UND+UN5
CDMA2000 (Rev 8)	cdma2000 (Revision 8) Waveform Generator	UND+101 ¹
W-CDMA (3GPP 3.2 03-00)	3GPP W-CDMA (Revision 3.2 March 2000) Waveform Generator	UND+100 ¹
W-CDMA (Rev 1.0-1.2)	W-CDMA (Revision 1.0-1.2) Waveform Generator	UND+100 ¹
W-CDMA (Trial 1998)	Wideband CDMA Waveform Generator (1998 Trial Version)	UND+H97 ¹
Other Formats	Digital Modulation Waveform Generator (single carrier or multicarrier)	UND
Bluetooth	Bluetooth Waveform Generator	UND
Multitone	Multitone Waveform Generator	UND
AWGN	Additive White Gaussian Noise Waveform Generator	UND

¹ Option is explained in separate manual.

$\pi/4$ DQPSK2

This key selects a $\pi/4$ Differential Quadrature Phase Shift Keying modulation. $\pi/4$ DQPSK modulation transmits data at the rate of 2 bits per symbol. Notice that the modulation selection is shown in the text area of the display in the `Mod Type` field and under the **Modulation Type** softkey. This softkey is only available when **Multicarrier Off On** is toggled to **Off**.

Softkey Location: **Mode > Other Formats > Digital Mod Define > Modulation Type > PSK > $\pi/4$ DQPSK**

of Carriers

This key enables you to set the number of carriers in the Other Formats Multicarrier Define table editor. You can use either the front-panel knob or the numeric keys to set the value. This menu is only available when **Multicarrier Off On** is toggled to **On**.

Range: 2 through 64

Default: 2

Softkey Location: **Mode > Other Formats > Multicarrier Off On > Multicarrier Define > Initialize Table > # of Carriers**

Skipped Points

This key enables you to set the number of points to skip in the range that you are defining. The first point in a range always has a marker set; the skipped points are after that marker. This enables you to set repetitively spaced markers. For example, a skip of 2 produces two points between each marker across the defined range. You can use either the front-panel knob or the numeric keys to set the value.

Default: 0

Softkey Location: **Mode > Dual ARB > Waveform Segments > Waveform Utilities > Set Markers > Set Marker On Range of Points > # Skipped Points**

Or: **Mode > Dual ARB > Select Waveform > Waveform Segments > Waveform Utilities > Set Markers > Set Marker On Range of Points > # Skipped Points**

Or: **Mode > Dual ARB > Waveform Sequence > Build New Waveform Sequence > Insert Waveform > Waveform Segments > Waveform Utilities > Set Markers > Set Marker On Range of Points > # Skipped Points**

Or: **Mode > Dual ARB > Waveform Sequence > Edit Selected Waveform Sequence > Insert Waveform > Waveform Segments > Waveform Utilities > Set Markers > Set Marker On Range of Points > # Skipped Points**

2-Lvl FSK

This key selects a 2-level frequency shift keying modulation. Two-level FSK modulation transmits data at the rate of 1 bit per symbol. The selected modulation appears in the `Mod_Type` field in the text area of the display, and under the **Modulation Type** softkey. This softkey is only available when **Multicarrier Off On** is toggled to **Off**.

Softkey Location: **Mode > Other Formats > Digital Mod Define > Modulation Type > FSK > 2-Lvl FSK**

2.500 MHz

This key selects a reconstruction filter with a cutoff frequency of 2.500 MHz.

Softkey Location: **Mode > CDMA Formats > IS-95A > CDMA Define > Reconstruction Filter >**

Or: **Mode > Dual ARB > ARB Setup > Reconstruction Filter > 2.500 MHz**

4-Lvl FSK

This key selects a 4-level frequency shift keying modulation. Four-level FSK modulation transmits data at the rate of 2 bits per symbol. The selected modulation appears in the `Mod_Type` field in the text area of the display, and under the **Modulation Type** softkey. This softkey is only available when **Multicarrier Off On** is toggled to **Off**.

Softkey Location: **Mode > Other Formats > Digital Mod Define > Modulation Type > FSK > 4-Lvl FSK**

4QAM

This key selects a 4-state quadrature amplitude modulation. 4QAM modulation transmits data at the rate of 2 bits per symbol. The selected modulation appears in the `Mod_Type` field in the text area of the display, and under the **Modulation Type** softkey. This softkey is only available when **Multicarrier Off On** is toggled to **Off**.

Softkey Location: **Mode > Other Formats > Digital Mod Define > Modulation Type > QAM > 4QAM**

8.000 MHz

This key selects a reconstruction filter with a 8.000 MHz cutoff frequency.

Softkey Location: **Mode > CDMA Formats > IS-95A > CDMA Define > Reconstruction Filter > 8.000 MHz**

Or: **Mode > Dual ARB > ARB Setup > Reconstruction Filter > 8.000 MHz**

8 Bit Pattern

This key enables you to enter an eight bit pattern for a Bluetooth setup. The 8 bit pattern is repeated 27 times within the payload of each packet. A change in the payload data type resets the eight bit pattern to the default value.

Default: 0000 0000

Softkey Location: **Mode > Bluetooth > Packet > Payload Data > 8 Bit Pattern**

8-Lvl FSK

This key selects an 8-level frequency shift keying modulation. Eight-level FSK modulation transmits data at the rate of 3 bits per symbol. The selected modulation appears in the `Mod Type` field in the text area of the display, and under the **Modulation Type** softkey. This softkey is only available when **Multicarrier Off On** is toggled to **Off**.

Softkey Location: **Mode > Other Formats > Digital Mod Define > Modulation Type > FSK > 8-Lvl FSK**

8PSK

This key selects an 8-state phase shift keying modulation. 8PSK modulation transmits data at the rate of 3 bits per symbol. The selected modulation appears in the `Mod Type` field in the text area of the display, and under the **Modulation Type** softkey. This softkey is only available when **Multicarrier Off On** is toggled to **Off**.

Softkey Location: **Mode > Other Formats > Digital Mod Define > Modulation Type > PSK > 8PSK**

9 Ch Fwd

This key selects a standard, forward 9 channel CDMA setup.

Using this setup, the signal generator transmits a 9 channel CDMA signal for forward transmission (base-to-mobile communication direction). Channel 1 is a pilot channel, channel 2 is a paging channel, channels 3 through 8 are traffic channels, and channel 9 is a sync channel. (These channel numbers are *not* equivalent to the Walsh code number.)

Softkey Location: **Mode > CDMA Formats > IS-95A > Setup Select > 9 Ch Fwd**

16-Lvl FSK

This key selects a 16-level frequency shift keying modulation. 16-level FSK modulation transmits data at the rate of 4 bits per symbol. The selected modulation appears in the `Mod Type` field in the text area of the display, and under the **Modulation Type** softkey. This softkey is only available when **Multicarrier Off On** is toggled to **Off**.

Softkey Location: **Mode > Other Formats > Digital Mod Define > Modulation Type > FSK > 16-Lvl FSK**

16PSK

This key selects a 16-state phase shift keying modulation. 16PSK modulation transmits data at the rate of 4 bits per symbol. The selected modulation appears in the `Mod Type` field in the text area of the display, and under the **Modulation Type** softkey. This softkey is only available when **Multicarrier Off On** is toggled to **Off**.

Softkey Location: **Mode > Other Formats > Digital Mod Define > Modulation Type > PSK > 16PSK**

16QAM

This key select a 16-state quadrature amplitude modulation. 16QAM modulation transmits data at the rate of 4 bits per symbol. The selected modulation appears in the `Mod Type` field in the text area of the display, and under the **Modulation Type** softkey. This softkey is only available when **Multicarrier Off On** is toggled to **Off**.

Softkey Location: **Mode > Other Formats > Digital Mod Define > Modulation Type > QAM > 16QAM**

32 Ch Fwd

This key selects a standard, forward 32 channel CDMA setup.

Using this setup, the signal generator will transmit a 32 channel CDMA signal for forward transmission (base-to-mobile communication direction). Channel 1 is a pilot channel, channel 2 is a paging channel, channels 3 through 26 and channels 28 through 32 are traffic channels, and channel 27 is a sync channel. (These channel numbers are *not* equivalent to the Walsh code number.)

Softkey Location: **Mode > CDMA Formats > IS-95A > Setup Select > 32 Ch Fwd**

32QAM

This key selects a 32-state quadrature amplitude modulation. 32QAM modulation transmits data at the rate of 5 bits per symbol. The selected modulation appears in the `Mod Type` field in the text area of the display, and under the **Modulation Type** softkey. This softkey is only available when **Multicarrier Off On** is toggled to **Off**.

Softkey Location: **Mode > Other Formats > Digital Mod Define > Modulation Type > QAM > 32QAM**

64 Ch Fwd

This key selects a standard, forward 64 channel CDMA setup.

Using this setup, the signal generator will transmit a 64 channel CDMA signal set independently for forward transmission (base-to-mobile communication direction). Channel 1 is a pilot channel, channels 2 through 8 are paging channels, channels 9 through 32 and channels 34 through 64 are traffic channels, and channel 33 is a sync channel. (These channel numbers are *not* equivalent to the Walsh code number.)

Softkey Location: **Mode > CDMA Formats > IS-95A > Setup Select > 64 Ch Fwd**

64QAM

This key select a 64-state quadrature amplitude modulation. 64QAM modulation transmits data at the rate of 6 bits per symbol. The selected modulation appears in the `Mod Type` field in the text area of the display, and under the **Modulation Type** softkey. This softkey is only available when **Multicarrier Off On** is toggled to **Off**.

Softkey Location: **Mode > Other Formats > Digital Mod Define > Modulation Type > QAM > 64QAM**

250.0 kHz

This key selects a reconstruction filter with a 250.0 kHz cutoff frequency.

Softkey Location: **Mode > CDMA Formats > IS-95A > CDMA Define > Reconstruction Filter > 250.0 kHz**

Or: **Mode > Dual ARB > ARB Setup > Reconstruction Filter > 250.0 kHz**

256QAM

This key selects a 256-state quadrature amplitude modulation. 256QAM modulation transmits data at the rate of 8 bits per symbol. The selected modulation appears in the `Mod Type` field in the text area of the display, and under the **Modulation Type** softkey. This softkey is only available when **Multicarrier Off On** is toggled to **Off**.

Softkey Location: **Mode > Other Formats > Digital Mod Define > Modulation Type > QAM > 256QAM**

16384

This key sets the length of the AWGN waveform to 16384 points.

Softkey Location: **Mode > AWGN > Waveform Length > 16384**

32768

This key sets the length of the AWGN waveform to 32768 points.

Softkey Location: **Mode > AWGN > Waveform Length > 32768**

65536

This key sets the length of the AWGN waveform to 65536 points.

Softkey Location: **Mode > AWGN > Waveform Length > 65536**

131072

This key sets the length of the AWGN waveform to 131072 points.

Softkey Location: **Mode > AWGN > Waveform Length > 131072**

262144

This key sets the length of the AWGN waveform to 262144 points.

Softkey Location: **Mode > AWGN > Waveform Length > 262144**

524288

This key sets the length of the AWGN waveform to 524288 points.

Softkey Location: **Mode > AWGN > Waveform Length > 524288**

1048576

This key sets the length of the AWGN waveform to 1048576 points.

Softkey Location: **Mode > AWGN > Waveform Length > 1048576**

Adjust Code Domain Power

This key accesses a menu that enables you to adjust the code domain power (the relative power in each of the channels) to **IS-97 Levels**, **Equal Powers** (all channels are of equal power and the total power equals 0 dB), **Scale to 0dB** (scale all of the current channel powers so that the total power equals 0 dB while keeping the previous power ratios between the individual channels). After making adjustments, you may view a graphical representation of the code domain power by pressing **Display Code Domain Power**.

Softkey Location: **Mode > CDMA Formats > IS-95A > CDMA Define > Edit Channel Setup > Adjust Code Domain Power**

AM_ADDR

This key enables you to assign a 3-bit slave address for Bluetooth. The active member address is used to distinguish between the active members participating on the piconet.

Range: 1 through 7

Default: 1

Softkey Location: **Mode > Bluetooth > Packet (DH1)> AM_ADDR**

APCO 25 C4FM

This key selects an APCO 25-specified C4FM filter in the **Select (filter)** menu. This is a Nyquist filter with an alpha of 0.2 which is combined with a shaping filter. This softkey is only available when **Multicarrier Off On** is toggled to **Off**.

Softkey Location: **Mode > Other Formats > Digital Mod Define > Filter > Select > APCO 25 C4FM**

Or: **Mode > CDMA Formats > IS-95A > CDMA Define > Filter > Select > APCO 25 C4FM**

APCO 25 w/C4FM

This key selects a predefined APCO 25-compliant personality with compatible 4-level frequency modulation for the digital modulation format. C4FM is a 4-level FSK (frequency shift keying) modulation that transmits data at the rate of 2 bits per symbol.

NOTE

APCO 25 (Association of Public-Safety Communications Officials - International, Inc., Project 25) is a standard-setting initiative for public-safety communications.

Softkey Location: **Mode > Other Formats > Setup Select > APCO 25 w/C4FM**

Or: **Mode > Other Formats > Multicarrier Off On > Multicarrier Define > Initialize Table > Carrier Setup > APCO 25 w/C4FM**

APCO 25 w/CQPSK

This key selects a predefined APCO 25-compliant personality with compatible quadrature phase shift keying for the digital modulation format. CQPSK uses $\pi/4$ DQPSK ($\pi/4$ differential quadrature phase shift keying) modulation that transmits data at the rate of 2 bits per symbol (4.8 ksps).

Softkey Location: **Mode > Other Formats > Setup Select > APCO 25 w/CQPSK**

Or: **Mode > Other Formats > Multicarrier Off On (until On is highlighted) > Multicarrier Define > Initialize Table > Carrier Setup > APCO 25 w/CQPSK**

Apply Channel Setup

This key applies the changes made in the channel setup table editor (see “[Edit Channel Setup](#)” on page 3-28). If the waveform is set to On, then the new channel data is used to generate a new modulation waveform in ARB waveform memory.

Softkey Location: **Mode > CDMA Formats > IS-95A > CDMA Define > Apply Channel Setup**

Apply Multicarrier

This key applies the changes made to the multicarrier CDMA or Other Formats setup using the Multicarrier Setup table editor (accessed by pressing the Multicarrier Define softkey). If Multicarrier Off On is On, then the new multicarrier data is used to generate a new CDMA or digital modulation waveform in volatile waveform memory when CDMA Off On, or Digital Modulation Off On is set to On.

Softkey Location: **Mode > CDMA Formats > IS-95A > Multicarrier Off On > Multicarrier Define > Apply Multicarrier**

Or: **Mode > Other Formats > Multicarrier Off On > Multicarrier Define > Apply Multicarrier**

Apply Multitone

This key applies, to the signal, any changes you have made in the phase or state parameters.

Softkey Location: **Mode > Multitone > Apply Multitone**

Apply to Waveform

This key is used to do the following:

1. create or delete markers over a range of points
2. change the scaling percentage of the selected waveform segment
3. change the clipping configuration of the selected waveform segment or CDMA waveform

Creating Markers

This key applies the defined set of markers to the selected waveform.

Softkey Location: **Mode > Dual ARB > Waveform Segments > Waveform Utilities > Set Markers > Set Marker On Range of Points > Apply to Waveform**

Deleting Markers

This key deletes all markers from the selected waveform that are within the defined range.

Softkey Location: **Mode > Dual ARB > Waveform Segments > Waveform Utilities > Set Markers > Set Marker Off Range of Points > Apply to Waveform**

Or: **Mode > Dual ARB > Select Waveform > Waveform Segments > Waveform Utilities > Set Markers > Set Marker On Range of Points > Apply to Waveform**

Or: **Mode > Dual ARB > Waveform Sequence > Build New Waveform Sequence > Insert Waveform > Waveform Segments > Waveform Utilities > Set Markers > Set Marker On Range of Points > Apply to Waveform**

Or: **Mode > Dual ARB > Waveform Sequence > Edit Selected Waveform Sequence > Insert Waveform > Waveform Segments > Waveform Utilities > Set Markers > Set Marker On Range of Points > Apply to Waveform**

Scaling Waveform Segments

This key applies the defined scaling percentage to the selected waveform segment.

Softkey Location: **Mode > Dual ARB > Waveform Segments > Waveform Utilities > Set Scaling > Apply to Waveform**

Clipping Waveform Segments

This key applies the defined clipping setup to the selected waveform segment.

Softkey Location: **Mode > Dual ARB > Waveform Segments > Waveform Utilities > Clipping > Apply to Waveform**

Clipping CDMA Waveforms

This key applies the current clipping settings you have selected to the waveform. Press Return if you do not want to apply the new settings at this time.

NOTE

The settings are applied the next time you generate a waveform.

Softkey Location: **Mode > CDMA Formats > IS-95A > CDMA Define > Clipping > Apply to Waveform**

ARB Off On

This key turns the operating state of the dual arbitrary waveform generator on and off.

Default: Off

Softkey Location: **Mode > Dual ARB > ARB Off On**

ARB Reference Ext Int

This key selects either an internal or an external reference for the waveform clock. If you choose external, you must enter the reference frequency (as described under the [Reference Freq](#) softkey) and the signal must be applied to the BASEBAND GEN REF IN connector.

Default: Int

Softkey Location: **Mode > CDMA Formats > IS-95A > CDMA Define >**

Or: Mode > Dual ARB > ARB Setup > ARB Reference Ext Int

ARB Sample Clock

This key enables you to adjust the sample clock rate. After entering the desired clock rate, terminate the entry with GHz, MHz, kHz, or Hz.

Range: 1.0 Hz through 40 MHz

Default: 6.1440000 MHz

Softkey Location: **Mode > Dual ARB > ARB Setup > ARB Sample Clock**

ARB Setup

This key accesses a menu for adjusting the ARB reference between internal and external (and the reference frequency for external ARB references), the frequency of the ARB sample clock, and the type of reconstruction filter.

Softkey Location: **Mode > Dual ARB > ARB Setup**

AWGN

This key appears in two places.

For an AWGN Waveform

This key accesses a menu of softkeys for configuring and generating an additive white gaussian noise waveform.

Softkey Location: **Mode > AWGN**

For Bluetooth Impairments

This key accesses a menu for configuring additive white gaussian noise as an impairment in a Bluetooth waveform.

NOTE

The **Impairments Off On** softkey must be in the **On** position for noise to be applied.

Softkey Location: **Mode > Bluetooth > Impairments > AWGN**

AWGN Off On

This key appears in two places.

For an AWGN Waveform

This key toggles the operating state of the AWGN waveform generator off or on.

Default: Off

Softkey Location: **Mode > AWGN > AWGN Off On**

For Bluetooth Impairments

This key toggles AWGN as a Bluetooth impairment off or on. The parameters set in the AWGN setup menu will not be implemented until both **AWGN Off On** and **Impairments Off On** are in the **On** state.

Softkey Location: **Mode > Bluetooth > Impairments > AWGN > AWGN Off On**

Bandwidth

This key enables you to adjust the bandwidth of the AWGN waveform.

Range: 50.000kHz through 15.000 MHz

Default: 1.000000 MHz

Softkey Location: **Mode > AWGN > Bandwidth**

BD_ADDR

This key enables you to allocate a unique 48-bit Bluetooth device address (BD_ADDR) for the device under test. This address is derived from the IEEE802 standard.

Default: 000000 00 0008

Softkey Location: **Mode** > **Bluetooth** > **Packet (DH1)** > **BD_ADDR**

Beta

This key is activated automatically when you select the Kaiser windowing function. The default Beta factor provides a good solution for optimizing out-of-band performance, adjacent channel power (ACP), without seriously compromising passband performance, error vector magnitude (EVM).

Changing the Beta factor adjusts the trade-off between ACP and EVM:

- Decreasing the value improves EVM.
- Increasing the value improves ACP.

Range: 1.000 through 10.000

Default: 4.000

Softkey Location: **Mode** > **Other Formats** > **Digital Mod Define** > **Filter** > **Define User FIR** > **Load Default FIR** > **Root Nyquist (Nyquist, Gaussian, or Rectangle)** > **Window** > **Kaiser** > **Beta**

Bluetooth

This key accesses a menu of softkeys for generating data patterns using the Bluetooth waveform generator.

Softkey Location: **Mode** > **Bluetooth**

Bluetooth Off On

This key toggles the operating state of the Bluetooth waveform generator between on or off.

Default: Off

Softkey Location: **Mode** > **Bluetooth** > **Bluetooth Off On**

BPSK

This key selects a binary phase shift keying modulation. BPSK modulation transmits data at the rate of 1 bit per symbol. The selected modulation appears in the `Mod Type` field in the text area of the display, and under the **Modulation Type** softkey. This softkey is only available when **Multicarrier Off On** is toggled to **Off**.

Softkey Location: **Mode > Other Formats > Digital Mod Define > Modulation Type > PSK > BPSK**

Build New Waveform Sequence

This key accesses a menu for creating a new waveform sequence file.

Softkey Location: **Mode > Dual ARB > Waveform Sequences > Build New Waveform Sequence**

Burst Off On

This key toggles the burst function for a Bluetooth setup between on or off. Burst on will ramp up the power at the beginning of the transmitted packet and ramp down at the end. Burst off will transmit packets linked in a series with no power ramping. This causes the **Burst Power Ramp** key to be grayed out.

Default: On

Softkey Location: **Mode > Bluetooth > Burst Off On**

Burst Power Ramp

This key enables you to set the duration of the power ramp up at the beginning of the packet transmission and down at the end of the packet.

Range: 1 through 10 symbols

Default: 6 symbols

Softkey Location: **Mode > Bluetooth > Burst Power Ramp**

Bus

This key sets the trigger source to bus. When the trigger source is set to bus, the signal generator will trigger an event when it receives the appropriate command via GPIB.

NOTE

For trigger availability information, see the **Trigger** softkey definition.

Softkey Location: **Mode > CDMA Formats > IS-95A > Trigger > Trigger Setup > Trigger Source > Bus**

Or: **Mode > Dual ARB > Trigger > Trigger Setup > Trigger Source > Bus**

Or: **Mode > Other Formats > Trigger > Trigger Setup > Trigger Source > Bus**

C4FM

This key selects a compatible 4-level frequency modulation as the modulation type. C4FM is an APCO 25-compliant, 4-level FSK (frequency shift keying) modulation that transmits data at the rate of two bits per symbol. This softkey is only available when **Multicarrier Off On** is toggled to **Off**.

Softkey Location: **Mode > Other Formats > Digital Mod Define > Modulation Type > FSK > C4FM**

Carrier Setup

This key accesses a menu for defining the type of carrier to be used in multicarrier mode digital modulation set up.

This softkey is only available when **Multicarrier Off On** is toggled to **On**.

Softkey Location: **Mode > Other Formats > Multicarrier Off On > Multicarrier Define > Initialize Table > Carrier Setup**

CDMA Define

This key accesses a menu for defining CDMA signal parameters such as channel setup, filter adjustments, oversample ratio, chip rate, and reconstruction filter parameters.

Softkey Location: **Mode > CDMA Formats > IS-95A > CDMA Define**

CDMA Formats

This key is available *only* if Option UND and any one or more of the following CDMA options are installed: UN5, 100, 101, and H97. This key accesses a menu listing the CDMA protocols installed in the source.

Softkey Location: **Mode > CDMA Formats**

CDMA Off On

This key enables the CDMA capability. Setting **CDMA Off On** to **On** sets up the internal hardware to generate the currently selected CDMA signal. The **CDMA** and **I/Q** annunciators are turned on in the display. Although the digital modulation is enabled with this softkey, the signal modulates the RF carrier only after you have set **Mod On/Off** to **On**.

Setting **CDMA Off On** to **On** presets the following softkeys in the **I/Q** menu: **I/Q Off On** is set to **On** and **I/Q Source** is set to **Int I/Q**. You can override these selections in the **I/Q** menu.

Default: Off

Softkey Location: **Mode** > **CDMA Formats** > **IS-95A** > **CDMA Off On**

CDPD

This key selects a predefined Cellular Digital Packet Data personality for the digital modulation format. CDPD uses MSK (minimum shift keying) modulation that transmits data at the rate of 1 bit per symbol (19.2 ksps).

Softkey Location: **Mode** > **Other Formats** > **Setup Select** > **CDPD**

Or: **Mode** > **Other Formats** > **Multicarrier Off On** (until **On** is highlighted) > **Multicarrier Define** > **Initialize Table** > **Carrier Setup** > **CDPD**

Chip Rate

This key enables you to set a new chip rate value. Enter the desired value, then press **Mcps**, **kcps**, or **cps** to terminate the entry.

Range: 10 cps to 20 Mcps (using a 2 times oversample rate)

Default: 1.228800 Mcps

Softkey Location: **Mode** > **CDMA Formats** > **IS-95A** > **CDMA Define** > **Chip Rate**

Clip | I+jQ | To

This key selects the modulation level of the combined I and Q waveform as the active function. You can then clip (limit) the level to a percentage of full scale. A level of 100.0% equates to no clipping.

Range: 10.0 through 100.0%, in 0.1% increments

Default: 100.0%

Softkey Location: **Mode > CDMA Formats > IS-95A > CDMA Define > Clipping > Clip |I+jQ| To**

Or: **Mode > Dual ARB > Waveform Segments > Waveform Utilities > Clipping > Clip |I+jQ| To**

Or: **Mode > Dual ARB > Select Waveform > Waveform Segments > Waveform Utilities > Clipping > Clip |I+jQ| To**

Clip | I | To

This key selects the modulation level of the I component as the active function. You can then clip (limit) the level to a percentage of full scale. A level of 100.0% equates to no clipping.

Range: 10.0 through 100.0%, in 0.1% increments

Default: 100.0%

Softkey Location: **Mode > CDMA Formats > IS-95A > CDMA Define > Clipping > Clip |I| To**

Or: **Mode > Dual ARB > Waveform Segments > Waveform Utilities > Clipping > Clip |I| To**

Or: **Mode > Dual ARB > Select Waveform > Waveform Segments > Waveform Utilities > Clipping > Clip |I| To**

Clip | Q | To

This key selects the modulation level of the Q component as the active function. You can then clip (limit) the level to a percentage of full scale. A level of 100.0% equates to no clipping.

Range: 10.0 through 100.0% in 0.1% increments

Default: 100.0%

Softkey Location: **Mode > CDMA Formats > IS-95A > CDMA Define > Clipping > Clip |Q| To**

Or: **Mode > Dual ARB > Waveform Segments > Waveform Utilities > Clipping > Clip |Q| To**

Or: Mode > Dual ARB > Select Waveform > Waveform Segments >
Waveform Utilities > Clipping > Clip |Q| To

Clip At PRE POST FIR Filter

This key selects whether you want the waveform clipped before (PRE) or after (POST) FIR filtering.

Default: PRE

Softkey Location: Mode > CDMA Formats > IS-95A > CDMA Define > Clipping >
Clip At PRE POST FIR Filter

Clipping

This key accesses a menu of options for limiting the modulation level.

Softkey Location: Mode > CDMA Formats > IS-95A > CDMA Define > Clipping

Or: Mode > Dual ARB > Waveform Segments > Waveform Utilities > Clipping

Or: Mode > Dual ARB > Select Waveform > Waveform Segments >
Waveform Utilities > Clipping

Clipping Type $|I+jQ|$ $|I|, |Q|$

This key selects either $|I+jQ|$ or $|I|, |Q|$ as the clipping type. If you select $|I+jQ|$, the combined I and Q waveform is clipped (*circular* clipping). If you select $|I|, |Q|$, the I and Q components of the waveform are clipped independently (*rectangular* clipping). In this case, you can clip I and Q to different levels.

Default: $|I+jQ|$

Softkey Location: Mode > CDMA Formats > IS-95A > CDMA Define > Clipping >
Clipping Type $|I+jQ|$ $|I|, |Q|$

Or: Mode > Dual ARB > Waveform Segments > Waveform Utilities > Clipping >
Clipping Type $|I+jQ|$ $|I|, |Q|$

Or: Mode > Dual ARB > Select Waveform > Waveform Segments >
Waveform Utilities > Clipping > Clipping Type $|I+jQ|$ $|I|, |Q|$

Clock/Gate Delay

This key enables you to specify the number of symbols to shift the clock and gate signals relative to the Bluetooth signal.

NOTE

This option is available only when the payload data is continuous PN9 and is intended to be used during bit error rate (BER) testing.

In the **Bert** softkey location, **Bluetooth Off On** must be toggled to the on position for the key to be active.

Shifted clock and gate signals emerge from the EVENT 1 and EVENT 2 rear panel connectors, respectively. When Clock/Gate Delay is set to 0, the rising edge of the clock lines up with the middle of each symbol, and the gate is high during the payload bits portion of the packet. The packet timing may shift, relative to the clock/gate timing, as it passes through a device under test. Use this key to restore the timing relationship by delaying the clock/gate the same amount as the packet.

Range: 0 through 24999.9 symbols

Default: 0

Softkey Location: **Mode > Bluetooth > Clock/Gate Delay**

Or: **Mode > Bert > Clock/Gate Delay**

C/N [1 MHz]

This key enables you to set the carrier to noise ratio, in a 1 MHz bandwidth, when the AWGN impairment is turned on.

Range: 10.0 dB through 40.0 dB

Default: 21.0 dB

Softkey Location: **Mode > Bluetooth > Impairments > AWGN > C/N (1 MHz)**

Continuous

This key sets the CDMA trigger type to continuous. In continuous trigger mode, the CDMA waveform will repeat itself indefinitely.

NOTE

For trigger availability information, see the **Trigger** softkey definition.

Softkey Location: **Mode > CDMA Formats > IS-95A > Trigger > Continuous**

Or: **Mode > Dual ARB > Trigger > Continuous**

Or: **Mode > Other Formats > Trigger > Continuous**

Continuous PN9

This key enters a continuous PN9 pattern in a Bluetooth setup. The PN9 payload data will place 8 continuous PN9 sequences into payloads of 19 packets. These packets are followed by one packet with no payload. The packet with no payload is included to ensure the SEQN bit is inverted with each new packet.

Softkey Location: **Mode > Bluetooth > Packet > Payload Data > Continuous PN9**

Custom CDMA Carrier

This key displays the CDMA memory catalog. From this catalog listing, you can choose a previously stored custom carrier setup.

Softkey Location: **Mode > CDMA Formats > IS-95A > Multicarrier Off On > Multicarrier Define > Edit Item > Custom CDMA Carrier**

Or: **Mode > CDMA Formats > IS-95A > Multicarrier Off On > Multicarrier Define > Insert Row > Custom CDMA Carrier**

Custom CDMA Multicarrier

This key displays the multicarrier CDMA memory catalog. From this catalog listing, you can choose a previously stored custom multicarrier setup.

Softkey Location: **Mode > CDMA Formats > IS-95A > Multicarrier Off On > Setup Select > Custom CDMA Multicarrier**

Custom CDMA State

This key displays the CDMA Setup Select File menu. From this menu, you can choose a custom CDMA setup that has previously been defined and stored in the signal generator's memory. Use the front-panel knob, arrow keys, or the data entry keypad to highlight the desired CDMA state file, then press **Select File** to activate the custom CDMA state.

Softkey Location: **Mode > CDMA Formats > IS-95A > Setup Select > Custom CDMA State**

Custom Digital Mod State

This key displays the Digital Modulation Setup Select File menu. From this menu, you can choose a custom digital modulation setup that has previously been defined and stored in the signal generator's memory. Use the front-panel knob, arrow keys, or the data entry keypad to highlight the desired file, then press **Select File** to activate the custom digital modulation state.

Softkey Location: **Mode > Other Formats > Setup Select > Custom Digital Mod State**

Or: **Mode > Other Formats > Multicarrier Off On > Multicarrier Define > Initialize Table > Carrier Setup > Custom Digital Mod State**

D8PSK

This key selects a differential 8-state phase shift keying modulation. D8PSK modulation transmits data at the rate of 3 bits per symbol. The selected modulation appears in the **Mod Type** field in the text area of the display, and under the **Modulation Type** softkey. This softkey is only available when **Multicarrier Off On** is toggled to **Off**.

Softkey Location: **Mode > Other Formats > Digital Mod Define > Modulation Type > PSK > D8PSK**

DECT

This key select a predefined Digital European Cordless Telecommunications personality for the digital modulation format.

Softkey Location: **Mode > Other Formats > Setup Select > DECT**

Or: **Mode > Other Formats > Multicarrier Off On > Multicarrier Define > Initialize Table > Carrier Setup > DECT**

Define User FIR

This key accesses a table editor for creating and modifying FIR filters. The FIR table editor allows a maximum filter length of 1024 coefficients with a maximum oversampling ratio of 32. An FIR filter selected for use in CDMA, however, cannot have more than 512 coefficients so the number of symbols and the oversample ratio should be selected accordingly. Example of using the FIR table editor are provided in the "Using Functions" chapter.

Softkey Location: **Mode > CDMA Formats > IS-95A > CDMA Define > Filter > Define User FIR**

Or: **Mode > Other Formats > Digital Mod Define > Filter > Define User FIR**

Delete All ARB Files

This key deletes all files from the volatile arbitrary waveform memory. Deletions cannot be recovered.

Softkey Location: **Mode > Dual ARB > Waveform Sequences > Delete All ARB Files**

Delete All NVARB Files

This key deletes all files from the nonvolatile arbitrary waveform memory. Deletions cannot be recovered.

Softkey Location: **Mode > Dual ARB > Waveform Sequences > Load > Delete All NVARB Files**

Delete All Rows

This key deletes all rows in the current table editor.

CAUTION

Deletions cannot be recovered.

Delete All Rows is located in some table editors.

Delete File

This key deletes the highlighted file from the displayed catalog. You will be prompted for confirmation.

Delete File is located in catalogs of files.

Delete Row

This key deletes the highlighted row in the table.

CAUTION

Deletions cannot be recovered.

Softkey Location: **Mode > CDMA Formats > IS-95A > CDMA Define > Edit Channel Setup > Delete Row**

Or: **Mode > CDMA Formats > IS-95A > CDMA Define > Filter > Define User FIR > Delete Row**

Or: **Mode > Other Formats > Digital Mod Define > Filter > Define User FIR > Delete Row**

Or: **Mode > Other Formats > Multicarrier Off On > Multicarrier Define > Delete Row**

Delete Segment

This key deletes the selected waveform segment in the displayed catalog. Note that confirmation is required, by pressing **Confirm Delete**, before the segment will be deleted. Deletions cannot be recovered. If you want to cancel confirmation, press the **Return** hardkey.

Softkey Location: **Mode > Dual ARB > Waveform Segments > Delete Segment**

Delete Selected Waveform

This key deletes the highlighted waveform. Deletions cannot be recovered.

Softkey Location: **Mode > Dual ARB > Waveform Sequences > Build New Waveform Sequence > Delete Selected Waveform**

Or: **Mode > Dual ARB > Waveform Sequences > Edit Selected Waveform Sequence > Delete Selected Waveforms**

Delete Waveform Sequence

This key deletes the highlighted waveform sequence from the displayed catalog. Deletions cannot be recovered. Note that confirmation is required, by pressing **Confirm Delete**, before the sequence will be deleted. Deletions cannot be recovered.

Softkey Location: **Mode > Dual ARB > Waveform Sequences > Delete Waveform Sequence**

Digital Mod Define

This key accesses a menu that enables you to set the symbol rate and assign a modulation type and filter for a custom digital modulation state. This menu also allows you to store the custom state to a file. Note that this softkey is only available when the **Multicarrier Off On** softkey is toggled to **Off**.

Softkey Location: **Mode > Other Formats > Digital Mod Define**

Digital Modulation Off On

This key toggles the operating state of the digital modulation format between on or off. Turning **Digital Modulation Off On** to **On** generates a waveform internally, according to the currently-selected parameters. You can either select the parameters according to a predefined standard (for instance, GSM) or set up individual parameters using the **Digital Mod Define** softkey. In all cases, the data in the waveform is a PN sequence.

Default: **Off**

Softkey Location: **Mode > Other Formats > Digital Modulation Off On**

Display Code Domain Power

This key displays a graphical representation of the code domain power. Power (in decibels) is represented on the y-axis and Walsh Code is represented on the x-axis.

The table represents the code domain power as a graph of the relationship between power in each channel (-40 to 0 dB) versus Walsh code (0 to highest code used in setup). Total code domain power is displayed above the graph.

The following is an example of a Code Domain Power graph.

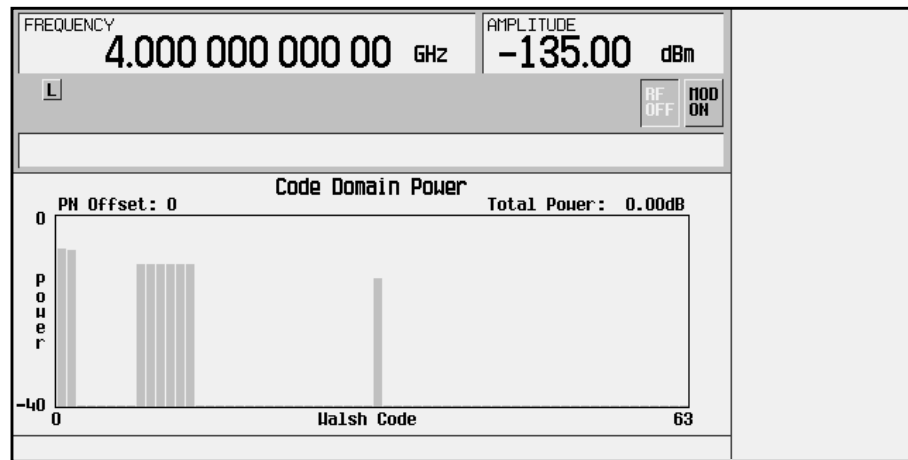

If there is channel data assigned to more than one PN offset, pressing the Display Code Domain Power softkey will open a menu where you can select Previous PN Offset or Next PN Offset.

The following is an example of the Code Domain Power graph display with the additional softkeys.



To return to the table editor and the menu keys, press Return.

Softkey Location: Mode > CDMA Formats > IS-95A > CDMA Define > Edit Channel Setup > Display Code Domain Power

Display FFT

This key displays a graphical representation of the frequency response of the filter loaded into the FIR table editor (calculated using a fast Fourier transform). The following is an example of the frequency response of a Root Nyquist filter with an oversample ratio of 4.

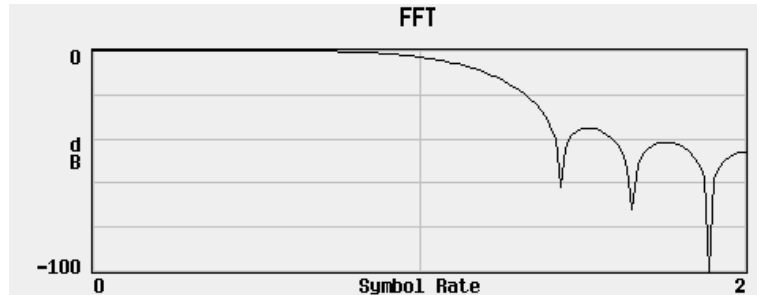

To return to the FIR table editor and the menu keys, press **Return**.

Softkey Location: **Mode** > **CDMA Formats** > **IS-95A** > **CDMA Define** > **Filter** > **Define User FIR** > **Display FFT**

Or: **Mode** > **Other Formats** > **Digital Mod Define** > **Filter** > **Define User FIR** > **Display FFT**

Display Impulse Response

This key displays a graphical representation of impulse response in time of the filter loaded into the FIR table editor. The following is an example of the impulse response of a Root Nyquist filter with an oversample ratio of 4.

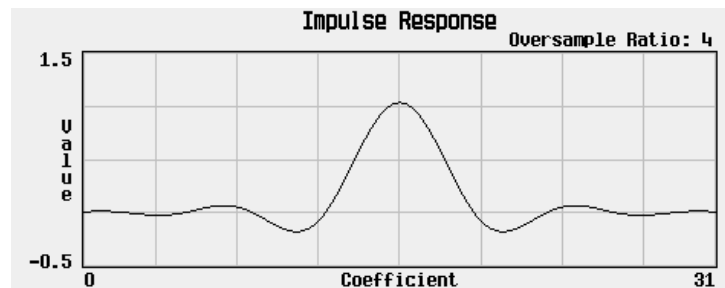

To return to the FIR table editor and the menu keys, press **Return**.

Softkey Location: **Mode** > **CDMA Formats** > **IS-95A** > **CDMA Define** > **Filter** > **Define User FIR** > **Display Impulse Response**

Or: **Mode** > **Other Formats** > **Digital Mod Define** > **Filter** > **Define User FIR** > **Display Impulse Response**

Done

This key is a terminator softkey. Press it to accept the current values for the item that you are setting up.

Done appears in table editor setup menus.

Done Inserting

This key ends the insertion mode and returns to the edit menu.

Softkey Location: **Mode > Dual ARB > Waveform Sequences > Build New Waveform Sequence > Insert Waveform > Done Inserting**

Or: **Mode > Dual ARB > Waveform Sequences > Edit Selected Waveform Sequence > Insert Waveform > Done Inserting**

Drift Deviation

This key enables you to set the maximum deviation of the frequency drift for linear carrier frequency ramping or sinusoidal frequency modulation of the carrier frequency.

Range: ± 0.0 kHz through ± 100.0 kHz

Default: ± 0.0 kHz

Softkey Location: **Mode > Bluetooth > Impairments > Drift Deviation**

Dual Arb

This key accesses a menu of softkeys for generating data patterns using the dual arbitrary waveform generator. Within these menus, you will be able to select and/or modify the waveform, waveform segments, waveform sequences, as well as the waveform generator's sample clock rate, internal/external reference (and with an external reference, the reference frequency) and reconstruction filter.

Softkey Location: **Mode > Dual ARB**

EDGE

This key selects a predefined Enhanced Data Rates for GSM Evolution personality for the digital modulation format. Selecting EDGE automatically configures the format with an EDGE filter and digital modulation type.

NOTE

The EDGE filter and digital modulation type are preset with the EDGE personality but unavailable with other formats. If you choose to modify the EDGE personality (for instance, if you replace the EDGE filter with a Nyquist filter), you will be unable to go back to an EDGE filter without choosing the predefined EDGE format again.

Softkey Location: **Mode > Other Formats > Setup Select > EDGE**

Or: **Mode > Other Formats > Multicarrier Off On > Multicarrier Define > Initialize Table > Carrier Setup > EDGE**

Edit Channel Setup

This key accesses a table editor that enables you to define the channel parameters of the current CDMA signal.

Use the front-panel knob or the arrow keys to move the cursor within the table structure, and the data input keypad to change values contained in the table.

You can move quickly through a large table using the keys found beneath the **Goto Row** softkey.

Softkey Location: **Mode > CDMA Formats > IS-95A > CDMA Define > Edit Channel Setup**

Edit Item

This key enables you to change the highlighted item in the displayed table.

Softkey Location: **Mode > CDMA Formats > IS-95A > CDMA Define > Edit Channel Setup > Edit Item**

Or: **Mode > CDMA Formats > IS-95A > CDMA Define > Filter > Define User FIR > Edit Item**

Or: **Mode > Multitone > Edit Item**

Or: **Mode > Other Formats > Digital Mod Define > Filter > Define User FIR > Edit Item**

Or: **Mode > Other Formats > Multicarrier Off On > Multicarrier Define > Edit Item**

Edit Repetitions

This key enables you to edit the amount of repetitions of the highlighted sequence. Use the front-panel arrow keys, knob, or numeric keypad to enter the number of repetitions.

Softkey Location: **Mode > Dual ARB > Waveform Sequences > Build New Waveform Sequence > Edit Repetitions**

Or: **Mode > Dual ARB > Waveform Sequences > Edit Selected Waveform Sequence > Edit Repetitions**

Edit Selected Waveform Sequence

This key accesses a menu for editing the selected waveform sequence.

Softkey Location: **Mode > Dual ARB > Waveform Sequences > Edit Selected Waveform Sequence**

Enter

This key is a terminator softkey that notifies the signal generator when you have completed a desired action. If you use the front-panel knob or keypad to enter a value, the signal generator completes the action only after you press **Enter**.

Equal Powers

This key sets the channel power levels to a state where all channels are of equal power and the total power equals 0 dBm.

Softkey Location: **Mode > CDMA Formats > IS-95A > CDMA Define > Edit Channel Setup > Adjust Code Domain Power > Equal Powers**

Ext

This key enables you to set the trigger source to external triggering. When the trigger source is set to external, the signal generator will trigger an event when it receives the appropriate signal via the PATTERN TRIG IN connector.

NOTE

For trigger availability information, see the **Trigger** softkey definition.

Softkey Location: **Mode > CDMA Formats > IS-95A > Trigger > Trigger Setup > Trigger Source > Ext**

Or: **Mode > Dual ARB > Trigger > Trigger Setup > Trigger Source > Ext**

Or: **Mode > Other Formats > Trigger > Trigger Setup > Trigger Source > Ext**

Ext Delay Off On

This key toggles the external trigger delay between on or off. To use external trigger delay, press this softkey until **Ext Delay On** is highlighted, and then set the external delay time by pressing the **Ext Delay Time** softkey.

NOTE

For trigger availability information, see the **Trigger** softkey definition.

Default: Off

Softkey Location: **Mode > CDMA Formats > IS-95A > Trigger > Trigger Setup > Trigger Source > Ext Delay Off On**

Or: **Mode > Dual ARB > Trigger > Trigger Setup > Trigger Source > Ext Delay Off On**

Or: **Mode > Other Formats > Trigger > Trigger Setup > Trigger Source > Ext Delay Off On**

Ext Delay Time

This key enables you to set the time for the external trigger delay. External trigger delay may be adjusted to trigger a waveform at a specified length of time after an external trigger signal has been received at the PATTERN TRIG IN connector. Enter a new value and press the **Enter** terminator softkey.

Range: 2.0 microseconds through 3600 seconds.

To use external trigger delay, press **Ext Delay Off On** until **On** is highlighted, and then set the external delay time by pressing the **Ext Delay Time** softkey.

NOTE

For trigger availability information, see the **Trigger** softkey definition.

Default: 2.000 milliseconds

Softkey Location: **Mode > CDMA Formats > IS-95A > Trigger > Trigger Setup > Trigger Source > Ext Delay Time**

Or: **Mode > Dual ARB > Trigger > Trigger Setup > Trigger Source > Ext Delay Time**

Or: **Mode > Other Formats > Trigger > Trigger Setup > Trigger Source > Ext Delay Time**

Ext Polarity Neg Pos

This key toggles the external trigger source polarity between either a positive change or a negative change in signal level. Depending on your choice, the signal generator will trigger an event when it receives the appropriate positive or negative change in signal at the PATTERN TRIG IN connector.

NOTE

For trigger availability information, see the **Trigger** softkey definition.

Default: Neg

Softkey Location: **Mode** > **CDMA Formats** > **IS-95A** > **Trigger** > **Trigger Setup** > **Trigger Source** > **Ext Polarity Neg Pos**

Or: **Mode** > **Dual ARB** > **Trigger** > **Trigger Setup** > **Trigger Source** > **Ext Polarity Neg Pos**

Or: **Mode** > **Other Formats** > **Trigger** > **Trigger Setup** > **Trigger Source** > **Ext Polarity Neg Pos**

Filter

This key accesses menus that enable you to select a filter type, restore the default filter, or define a unique FIR filter. The Filter menu also lets you adjust the filter alpha (when Nyquist or Root Nyquist filters are selected) or bandwidth time product (for Gaussian filters). You may also define filters in the single carrier mode (**Multicarrier Off On** toggled to **Off**) for the digital modulation format.

Softkey Location: **Mode** > **CDMA Formats** > **IS-95A** > **CDMA Define** > **Filter**

Or: **Mode** > **Other Formats** > **Digital Mod Define** > **Filter**

Filter Alpha

This key enables you to change the FIR filter's alpha parameter in either the Filter menu or the Load Default FIR menus.

In the Filter menu, the **Filter Alpha** softkey changes the alpha parameter of the selected Root Nyquist or Nyquist filter. To enter a new value, rotate the front-panel knob until the desired value is displayed, use the up and down arrow keys, or enter the value using the numeric keypad and press the **Enter** terminator softkey.

This key only appears *after* choosing a Root Nyquist or Nyquist filter. If a Gaussian filter is in use, you will see **Filter BbT**. If any other filter is in use, you will see a grayed-out softkey: **Filter Factor N/A**.

Range: 0.000 through 1.000

Default: 0.500

Softkey Location: **Mode > CDMA Formats > IS-95A > CDMA Define > Filter > Filter Alpha**

Or: **Mode > Other Formats > Digital Mod Define > Filter > Filter Alpha**

In the Load Default FIR menus, the **Filter Alpha** softkey changes the alpha parameter of the Root Nyquist or Nyquist filter coefficients loaded into the FIR table editor. After entering the alpha value, press **Generate** to modify the filter coefficients in the table editor.

Range: 0.000 through 1.000

Default: 0.350

Softkey Location: **Mode > CDMA Formats > IS-95A > CDMA Define > Filter > Define User FIR > Load Default FIR > Root Nyquist (or Nyquist) > Filter Alpha**

Or: **Mode > Other Formats > Digital Mod Define > Filter > Define User FIR > Load Default FIR > Root Nyquist (or Nyquist) > Filter Alpha**

Filter BbT

This key enables you to change the bandwidth-multiplied-by-bit-time (BbT) filter parameter in either the Filter menu or the Load Default FIR menu.

In the Filter menu, the **Filter BbT** softkey changes the BbT parameter of the selected Gaussian filter. To enter a new value, rotate the front-panel knob until the desired value is displayed, use the up and down arrow keys, or enter the value using the numeric keypad and press the **Enter** terminator softkey.

This key only appears *after* choosing a Gaussian filter. If a Root Nyquist or Nyquist filter is in use, you will see **Filter Alpha**. If any other filter is in use, you will see a grayed-out softkey: **Filter Factor N/A**.

Range: 0.000 through 1.000

Default: 0.500

Softkey Location: **Mode > CDMA Formats > IS-95A > CDMA Define > Filter > Select > Gaussian > Filter BbT**

Or: **Mode > Other Formats > Digital Mod Define > Filter > Select > Gaussian > Filter BbT**

In the Load Default FIR menu, the **Filter BbT** softkey changes the BbT parameter of the Gaussian filter coefficients loaded into the FIR table editor. After entering the BbT value, press **Generate** to modify the filter coefficients in the table editor.

Default: 0.300

Softkey Location: **Mode > CDMA Formats > IS-95A > CDMA Define > Filter > Define User FIR > Load Default FIR > Gaussian > Filter BbT**

Or: **Mode > Other Formats > Digital Mod Define > Filter > Define User FIR > Load Default FIR > Gaussian > Filter BbT**

Filter Factor N/A

This grayed-out key is displayed when a filter is in use that doesn't contain an adjustable alpha or BbT parameter (such as the IS-95 filter selections or a user-defined FIR filter). This softkey changes to either **Filter Alpha** or **Filter BbT** if the appropriate Root Nyquist, Nyquist, or Gaussian filter is selected for use.

Softkey Location: **Mode > CDMA Formats > IS-95A > CDMA Define > Filter > Filter Factor N/A**

Or: **Mode > Other Formats > Digital Mod Define > Filter > Filter Factor N/A**

Filter Symbols

This key enables you to define the number of symbols for the filter to be loaded into the FIR table editor. The FIR table editor allows a maximum filter length of 1024 coefficients with a maximum oversample ratio of 32 and a maximum of 32 symbols. An FIR filter selected for use in CDMA, however, cannot have more than 512 coefficients so the number of symbols and the oversample ratio should be selected accordingly.

Range: 1 through 32

Default: 8

Softkey Location: **Mode > CDMA Formats > IS-95A > CDMA Define > Filter > Define User FIR > Load Default FIR > Root Nyquist (Nyquist, Gaussian or Rectangle) > Filter Symbols**

Or: **Mode > Other Formats > Digital Mod Define > Filter > Define User FIR > Load Default FIR > Root Nyquist (Nyquist, Gaussian, or Rectangle) > Filter Symbols**

First Mkr Point

This key defines the *first* marker point when you define a range of points. You can use either the front-panel knob or the numeric keys to set this value, which must be ≥ 1 , and \leq the total number of waveform points in the selected waveform.

Default: 1

Creating Markers

Softkey Location: Mode > Dual ARB > Waveform Segments > Waveform Utilities > Set Markers > Set Marker On Range of Points > First Mkr Point

Or: Mode > Dual ARB > Select Waveform > Waveform Segments > Waveform Utilities > Set Markers > Set Marker On Range of Points > First Mkr Point

Or: Mode > Dual ARB > Waveform Sequence > Build New Waveform Sequence > Insert Waveform > Waveform Segments > Waveform Utilities > Set Markers > Set Marker On Range of Points > First Mkr Point

Or: Mode > Dual ARB > Waveform Sequence > Edit Selected Waveform Sequence > Insert Waveform > Waveform Segments > Waveform Utilities > Set Markers > Set Marker On Range of Points > First Mkr Point

Deleting Markers

Softkey Location: Mode > Dual ARB > Waveform Segments > Waveform Utilities > Set Markers > Set Marker Off Range of Points > First Mkr Point

Or: Mode > Dual ARB > Select Waveform > Waveform Segments > Waveform Utilities > Set Markers > Set Marker Off Range of Points > First Mkr Point

Or: Mode > Dual ARB > Waveform Sequence > Build New Waveform Sequence > Insert Waveform > Waveform Segments > Waveform Utilities > Set Markers > Set Marker Off Range of Points > First Mkr Point

Or: Mode > Dual ARB > Waveform Sequence > Edit Selected Waveform Sequence > Insert Waveform > Waveform Segments > Waveform Utilities > Set Markers > Set Marker Off Range of Points > First Mkr Point

Freq Dev

This key selects a symmetric FSK frequency deviation and makes it the active function. This softkey is only available when **Multicarrier Off On** is toggled to **Off**.

Range:

Minimum Value: 0 Hz

Maximum Value: depends upon the symbol rate

Default:

- DECT: 288 kHz
- APCO 25 C4FM: 1.8 kHz
- Other Formats: 400.00 Hz

Softkey Location: **Mode > Other Formats > Digital Mod Define >**

Modulation Type > FSK > Freq Dev

Freq Drift Type Linear Sine

This key toggles the frequency drift type between linear and sine. This enables you to select an optional frequency drift impairment as part of a Bluetooth setup. Linear frequency drift will occur across a period of time equal to the duration of one fully loaded DH1 packet, regardless of the packet length. The sine drift deviation (FM) is plus or minus from the carrier center frequency.

Default: Sine

Softkey Location: **Mode > Bluetooth > Impairments > Freq Drift Type Linear Sine**

Freq Offset

This key enables you to set an optional frequency offset impairment as part of a Bluetooth setup.

Range: -100.0 kHz through 100.0 kHz

Default: 0.0 kHz

Softkey Location: **Mode > Bluetooth > Impairments > Freq Offset**

Freq Spacing

Multitone

This key enables you to set the spacing between tones in the multitone table editor. This is done as part of initializing the table editor. See “Using the Multitone Waveform Generator” on page 2-46 for details.

Range: 100 Hz through 5 MHz

Default: 10.000 kHz

Softkey Location: **Mode > Multitone > Initialize Table > Freq Spacing**

Other Formats

This key enables you to initialize the multicarrier table. This is done as part of initializing the table editor. This softkey is only available when **Multicarrier Off On** is toggled to **On**.

Range: 100 Hz through 5 MHz

Default: 1.000 MHz

Softkey Location: **Mode > Other Formats > Multicarrier Off On (until On is highlighted) > Multicarrier Define > Initialize Table > Freq Spacing**

FSK

This key accesses a menu of frequency shift keying modulation types for modulating a continuous stream of the selected data pattern; you can also change the default frequency deviation. The modulation choices are:

- 2-Lvl FSK
- 4-Lvl FSK
- 8-Lvl FSK
- 16-Lvl FSK
- C4FM

This softkey is only available when **Multicarrier Off On** is toggled to **Off**.

Softkey Location: **Mode > Other Formats > Digital Mod Define > Modulation Type > FSK**

Gate Active Low High

Once the trigger has been set to **Gated**, press **Gate Active Low High** to change the polarity of the “through” or active state of a gated trigger signal. **Gate Active Low** will output the signal while the gate is low at the PATTERN TRIG IN connector. **Gate Active High** has the opposite effect, outputting the signal while the signal level at the PATTERN TRIG IN connector is in a high state.

NOTE

For trigger availability information, see the [Trigger](#) softkey definition.

Softkey Location: **Mode > CDMA Formats > IS-95A > Trigger > Gated > Trigger Setup > Gate Active Low High**

Or: **Mode > Dual ARB > Trigger > Gated > Trigger Setup > Gate Active Low High**

Or: **Mode > Other Formats > Trigger > Gated > Trigger Setup > Gate Active Low High**

Gate Active N/A

This key remains grayed-out until the trigger is set to **Gated**. Once the trigger has been set to **Gated**, press **Gate Active Low High** to toggle the polarity of the “through” or active state of a gated trigger signal. **Gate Active Low** will output the signal while the gate is low at the PATTERN TRIG IN connector. **Gate Active High** has the opposite effect, outputting the signal while the signal level at the PATTERN TRIG IN connector is in a high state.

NOTE

For trigger availability information, see the [Trigger](#) softkey definition.

Softkey Location: **Mode > CDMA Formats > IS-95A > Trigger > Trigger Setup > Gate Active N/A**

Or: **Mode > Dual ARB > Trigger > Trigger Setup > Gate Active N/A**

Or: **Mode > Other Formats > Trigger > Trigger Setup > Gate Active N/A**

Gated

This key sets the trigger type to **Gated**. Using a gated trigger, you can set the signal to output when a TTL high or low is present at the PATTERN TRIG IN connector. To set the gate to trigger on either high or low, press **Gated** and then press **Trigger Setup > Gate Active Low High**.

NOTE

For trigger availability information, see the [Trigger](#) softkey definition.

Softkey Location: **Mode > CDMA Formats > IS-95A > Trigger > Gated**

Or: **Mode > Dual ARB > Trigger > Gated**

Or: **Mode > Other Formats > Trigger > Gated**

Gaussian

This key selects the Gaussian pre-modulation filter in either the Select (filter) menu or the Load Default FIR menu.

In the Select (Filter) Menu

This key selects a Gaussian filter for use in the filter setup. Select the **Filter Bbt** softkey to change the filter bandwidth-multiplied-by-bit-time product value.

Range (Filter BbT): 0.000 through 1.000

Default (Filter BbT): 0.500.

Softkey Location: **Mode > CDMA Formats > IS-95A > CDMA Define > Filter > Select > Gaussian**

Or: **Mode > Other Formats > Digital Mod Define > Filter > Select > Gaussian**

In the Load Default FIR Menu

Pressing the **Gaussian** softkey followed by **Generate** loads the FIR table editor with the coefficient values for the Gaussian filter. The filter BbT and number of filter symbols are defined with the softkeys in this menu. If you change either parameter after loading the filter coefficients, press the **Generate** softkey again to reload the FIR table.

The **Display Impulse Response** and **Display FFT** softkeys in this menu graphically display the filter as it is currently defined in the FIR table editor.

Softkey Location: **Mode > CDMA Formats > IS-95A > CDMA Define > Filter > Define User FIR > Load Default FIR > Gaussian**

Or: **Mode > Other Formats > Digital Mod Define > Filter > Define User FIR > Load Default FIR > Gaussian**

Generate

This key enables you to generate the user-defined filter using the alpha or BbT value and number of symbols specified. This softkey is only available when **Multicarrier Off On** is toggled to **Off**.

Default: 8

Softkey Location: **Mode > Other Formats > Digital Mod Define > Filter > Define User FIR > Load Default FIR > Root Nyquist (or Nyquist, Gaussian, or Rectangle) > Generate**

Goto Bottom Row

This key moves the selection bar to the bottom row in the current table or list.

Goto Bottom Row is located in table editor menus and in catalogs of files.

Goto Middle Row

This key moves the selection bar to the middle row in the current table or list.

Goto Middle Row is located in table editor menus and in catalogs of files.

Goto Row

This key displays softkeys that enable you to select a row or page in a table.

Goto Row is located in table editor menus and in catalogs of files.

Goto Top Row

This key moves the selection bar to the top row in the current table or list.

Goto Top Row is located in table editor menus and in catalogs of files.

Gray Coded QPSK

This key selects a gray coded quadrature phase shift keying modulation. The Gray Coded QPSK modulation transmits data at the rate of 2 bits per symbol. The constellations for this modulation type are designed so that adjacent symbols differ by only one bit. The modulation selection appears in the `Mod Type` field in the text area of the display, and under the **Modulation Type** softkey. This softkey is only available when **Multicarrier Off On** is toggled to **Off**.

Softkey Location: **Mode > Other Formats > Digital Mod Define > Modulation Type > PSK > QPSK and OQPSK > Gray Coded QPSK**

GSM

This key selects a predefined GSM (Global System for Mobile Communication) personality for the digital modulation format.

Softkey Location: **Mode > Other Formats > Setup Select > GSM**

Or: **Mode > Other Formats > Multicarrier Off On (until On is highlighted) > Multicarrier Define > Initialize Table > Carrier Setup > GSM**

Hamming

This key selects a Hamming window to be applied to the generated user-defined filter. This softkey is available only when **Multicarrier Off On** is toggled to **Off**.

Softkey Location: **Mode > Other Formats > Digital Mod Define > Filter > Define User FIR > Load Default FIR > Root Nyquist (or Nyquist, Gaussian, or Rectangle) > Window > Hamming**

Hann

This key selects a Hann window to be applied to the generated user-defined filter. This softkey is available only when **Multicarrier Off On** is toggled to **Off**.

Softkey Location: **Mode > Other Formats > Digital Mod Define > Filter > Define User FIR > Load Default FIR > Root Nyquist (or Nyquist, Gaussian, or Rectangle) > Window > Hann**

Impairments

This key accesses a menu that enables you to add impairments to a Bluetooth signal. Refer to [“Setting up Impairments”](#) on page 2-95, for an example of how to set impairments.

Softkey Location: **Mode > Bluetooth > Impairments**

Impairments Off On

This key toggles the impairment function between off and on. The impairment options are applied only when the **Impairments Off On** is toggled to **On**.

Default: Off

Softkey Location: **Mode > Bluetooth > Impairments > Impairments Off On**

Initialize Phase Fixed Random

This key selects either fixed or random phase settings for the tones, as part of initializing the multitone table editor. **Fixed** sets the phase of all tones to 0 degrees. **Random** sets the phase of the tones to randomly generated phases based on the **Random Seed Fixed Random** softkey selection. See [“Creating a Multitone Waveform”](#) on page 2-47 for details.

Default: Fixed

Softkey Location: **Mode > Multitone > Initialize Table > Initialize Phase Fixed Random**

Initialize Table

This key accesses a menu that enables you to set the initial values for the multitone or Other Formats multicarrier table editor. This is also the menu you use to change the frequency spacing and the number of tones for multitone or the frequency spacing, number of carriers and carrier setup for Other Formats multicarrier.

Softkey Location: **Mode > Multitone > Initialize Table**

Or: **Mode > Other Formats > Multicarrier Off On > Multicarrier Define > Initialize Table**

Insert Row

This key to accesses a menu that enables you to select the type of row you wish to insert into the current table editor.

Softkey Location: **Mode > CDMA Formats > IS-95A > CDMA Define > Edit Channel Setup > Insert Row**

Or: **Mode > CDMA Formats > IS-95A > CDMA Define > Filter > Define User FIR > Insert Row**

Or (with Multicarrier Off On toggled to Off). **Mode > Other Formats > Digital Mod Define > Filter > Define User FIR > Insert Row**

Or (with Multicarrier Off On toggled to On): **Mode > Other Formats > Multicarrier Define > Insert Row**

Insert Selected Waveform

This key inserts the highlighted waveform into the sequence you are building.

Softkey Location: **Mode > Dual ARB > Waveform Sequences > Build New Waveform Sequence > Insert Waveform > Insert Selected Waveform**

Or: **Mode > Dual ARB > Waveform Sequences > Edit Selected Waveform Sequence > Insert Waveform > Insert Selected Waveform**

Insert Waveform

This key accesses a menu and table editor which enables you to insert a waveform to the current row of the table editor.

Softkey Location: **Mode > Dual ARB > Waveform Sequences > Build New Waveform Sequence > Insert Waveform**

Or: **Mode > Dual ARB > Waveform Sequences > Edit Selected Waveform Sequence > Insert Waveform**

Insert Waveform Sequence Contents

This key inserts the contents of the highlighted sequence into the sequence you are building.

Softkey Location: **Mode > Dual ARB > Waveform Sequences > Build New Waveform Sequence > Insert Waveform > Insert Waveform Sequence Contents**

Or: **Mode > Dual ARB > Waveform Sequences > Edit Selected Waveform Sequence > Insert Waveform > Insert Waveform Sequence Contents**

IS-95

This key selects the standard IS-95 baseband filter.

Default: IS-95 Mod w/EQ

Softkey Location: **Mode > CDMA Formats > IS-95A > CDMA Define > Filter > Select > IS-95 and IS-2000 > IS-95**

Or: **Mode > Other Formats > Digital Mod Define > Filter > Select > IS-95 and IS-2000 > IS-95**

IS-95 and IS-2000

This key accesses a menu of IS-95 and IS-2000 filters in the Select Filter menu.

This softkey is only available when **Multicarrier Off On** is toggled to **Off**.

Softkey Location: **Mode > Other Formats > Digital Mod Define > Filter > Select > IS-95 and IS-2000**

Or: **Mode > CDMA Formats > IS-95A > CDMA Define > Filter > Select > IS-95 and IS-2000**

IS-95A

This key is available *only* if both Option UND and Option UN5 have been installed.

This key accesses a menu of softkeys for generating data patterns that are formatted into a structure defined by the IS-95A protocol.

Signal generators with Options UND and UN5 can provide five different predefined CDMA setups (pilot, 9-channel, 32-channel, 64-channel forward, and reverse) with four different forward channel

types (pilot, traffic, paging, and sync) and one reverse channel type (traffic). IS-95 filtering options are also provided, as well as the ability to create, apply and store user-defined FIR filters.

Custom CDMA channel setups include five, independently variable parameters: channel type, Walsh code, power, PN offset, and data (inserted before the Walsh code sequence for forward setups and at the short code sequence for the reverse setup).

Custom multicarrier CDMA predefined setups include three, independently variable parameters: carrier type, frequency offset, and power.

Softkey Location: **Mode > CDMA Formats > IS-95A**

IS-95 Mod

This key selects a modified version of the standard IS-95 baseband filter. This filter is modified for improved adjacent channel performance. The modification, however, is done in a manner that still meets the IS-95 error function criterion.

Softkey Location: **Mode > CDMA Formats > IS-95A > CDMA Define > Filter > Select > IS-95 and IS-2000 > IS-95 Mod**

Or: **Mode > Other Formats > Digital Mod Define > Filter > Select > IS-95 and IS-2000 > IS-95 Mod**

IS-95 Mod w/EQ

This key selects a modified version of the standard IS-95 baseband filter. This filter is modified for improved adjacent channel performance, and includes the equalizer specified by IS-95. The filter modification is done in a manner that still meets the IS-95 error function criterion.

Softkey Location: **Mode > CDMA Formats > IS-95A > CDMA Define > Filter > Select > IS-95 and IS-2000 > IS-95 Mod w/EQ**

Or: **Mode > Other Formats > Digital Mod Define > Filter > Select > IS-95 and IS-2000 > IS-95 Mod w/EQ**

IS95 OQPSK

This key selects IS95 offset quadrature phase shift keying as the modulation type. This modulation has 2 bits per symbol. This softkey is only available when Multicarrier Off On is toggled to Off.

Softkey Location: **Mode > Other Formats > Digital Mod Define > Modulation Type > PSK > QPSK and OQPSK > IS95 OQPSK**

IS95 QPSK

This key selects IS95 quadrature phase shift keying as the modulation type. This modulation has 2 bits per symbol. This softkey is only available when **Multicarrier Off On** is toggled to **Off**.

Softkey Location: **Mode > Other Formats > Digital Mod Define > Modulation Type > PSK > QPSK and OQPSK > IS95 QPSK**

IS-95 w/EQ

This key selects the standard IS-95 baseband filter with an equalizer provided for phase compensation required by the base station.

Softkey Location: **Mode > CDMA Formats > IS-95A > CDMA Define > Filter > Select > IS-95 > IS-95 w/EQ**

Or: **Mode > Other Formats > Digital Mod Define > Filter > Select > IS-95 and IS-2000 > IS-95 w/EQ**

IS-97 Levels

This key sets the channel power levels to IS-97 levels.

Softkey Location: **Mode > CDMA Formats > IS-95A > CDMA Define > Edit Channel Setup > Adjust Code Domain Power > IS-97 Levels**

IS-2000 SR3 DS

This key selects the standard IS-2000 spreading rate 3, direct spread filter. This softkey is only available when **Multicarrier Off On** is toggled to **Off**.

Softkey Location: **Mode > Other Formats > Digital Mod Define > Filter > Select > IS-95 and IS-2000 > IS-2000 SR3 DS**

Or: **Mode > CDMA Formats > IS-95A > CDMA Define > Filter > Select > IS-95 and IS-2000 > IS-2000 SR3 DS**

Kaiser

This key selects a Kaiser window to be applied to the generated user-defined filter. The Beta factor may be adjusted in a submenu. This softkey is only available when **Multicarrier Off On** is toggled to **Off**.

Softkey Location: **Mode > Other Formats > Digital Mod Define > Filter > Define User FIR > Load Default FIR > Root Nyquist (Nyquist, Gaussian, or Rectangle) > Window > Kaiser**

Last Mkr Point

This key defines the *last* marker point when you define a range of points over which to either create or delete a marker. You can use either the front-panel knob or the numeric keys to set this value, which must be ≥ 1 , and \leq the total number of waveform points in the selected waveform.

If you enter a value for either the first marker point or the last marker point that would make the first marker point occur *after* the last, the last marker point is automatically adjusted to match the first marker point.

Default: Last marker point in selected waveform segment.

Creating Markers

Softkey Location: Mode > Dual ARB > Waveform Segments >
Waveform Utilities > Set Markers > Set Marker On Range of Points > Last Mkr Point

Or: Mode > Dual ARB > Select Waveform > Waveform Segments >
Waveform Utilities > Set Markers > Set Marker On Range of Points > Last Mkr Point

Or: Mode > Dual ARB > Waveform Sequence > Build New Waveform Sequence >
Insert Waveform > Waveform Segments > Waveform Utilities > Set Markers >
Set Marker On Range of Points > Last Mkr Point

Or: Mode > Dual ARB > Waveform Sequence >
Edit Selected Waveform Sequence > Insert Waveform > Waveform Segments >
Waveform Utilities > Set Markers > Set Marker On Range of Points > Last Mkr Point

Deleting Markers

Softkey Location: Mode > Dual ARB > Waveform Segments >
Waveform Utilities > Set Markers > Set Marker Off Range of Points > Last Mkr Point

Or: Mode > Dual ARB > Select Waveform > Waveform Segments >
Waveform Utilities > Set Markers > Set Marker Off Range of Points > Last Mkr Point

Or: Mode > Dual ARB > Waveform Sequence >
Edit Selected Waveform Sequence > Insert Waveform > Waveform Segments >
Waveform Utilities > Set Markers > Set Marker Off Range of Points > Last Mkr Point

Or: Mode > Dual ARB > Waveform Sequence > Build New Waveform Sequence >
Insert Waveform > Waveform Segments > Waveform Utilities > Set Markers >
Set Marker Off Range of Points > Last Mkr Point

Load Default FIR

This key accesses a menu of default filter types with standard filter parameters. The choices are: Root Nyquist, Nyquist, Gaussian, and Rectangle. A selection will automatically fill the FIR Values table editor with the pre-defined filter coefficients. Depending on the filter selected, a menu will be enabled listing filter alpha, filter BbT, filter symbols and windowing. These can be edited where appropriate. If any default parameters, for example, filter alpha, filter BbT, or filter symbols are changed then press the generate softkey to create the filter.

Softkey Location: **Mode > CDMA Formats > IS-95A > CDMA Define > Filter > Define User FIR > Load Default FIR**

Or: **Mode > Other Formats > Digital Mod Define > Filter > Define User FIR > Load Default FIR**

Load From Selected File

This key replaces the current information in a table editor with the information stored in the highlighted file.

Load From Selected File is located in catalogs of files.

Load Store

This key toggles between either load or store waveform segments to the two displayed catalog windows.

Softkey Location: **Mode > Dual ARB > Select Waveform > Waveform Segments > Load Store**

Load/Store

This key accesses a menu for loading a table editor with values from files previously stored in the signal generator memory, and for saving to memory a user-defined signal from the table editor.

Softkey Location: **Mode > CDMA Formats > IS-95A > CDMA Define > Filter > Define User FIR > Load/Store**

Or: **Mode > Multitone > Load/Store**

Or: **Mode > Other Formats > Digital Mod Define > Filter > Define User FIR > Load/Store**

Or: **Mode > Other Formats > Multicarrier Off On (until On is highlighted) > Multicarrier Define > Load/Store**

Marker 1 2

This key selects the active marker for setting or clearing.

Default: Marker 1

Softkey Location: **Mode > Dual ARB > Waveform Segments > Waveform Utilities > Set Markers > Set Marker 1 2**

Or: **Mode > Dual ARB > Select Waveform > Waveform Segments > Waveform Utilities > Set Markers > Set Marker 1 2**

Or: **Mode > Dual ARB > Waveform Sequence > Build New Waveform Sequence > Insert Waveform > Waveform Segments > Waveform Utilities > Set Markers > Set Marker 1 2**

Or: **Mode > Dual ARB > Waveform Sequence > Edit Selected Waveform Sequence > Insert Waveform > Waveform Segments > Waveform Utilities > Set Markers > Set Marker 1 2**

Marker Polarity Neg Pos

This key toggles the polarity of *both* markers to either active positive or active negative.

Default: Positive

Softkey Location: **Mode > Dual ARB > Arb Setup > Marker Polarity Neg Pos**

Mirror Table

This key mirrors the FIR table entries such that the table doubles in size, and the values in the top half of the table are duplicated in the bottom half of the table in reverse order.

Softkey Location: **Mode > CDMA Formats > IS-95A > CDMA Define > Filter > Define User FIR > Mirror Table**

Or: **Mode > Other Formats > Digital Mod Define > Filter > Define User FIR > Mirror Table**

Mkr 2 To RF Blank Off On

This key enables or disables RF blanking when marker 2 is low.

Default: Off

Softkey Location: **Mode > Dual ARB > Arb Setup > Mkr 2 To Blank Off On**

Mod Index

This key enables you to set the modulation index (similar to FM index) for a Bluetooth signal.

Range: 0.250 though 0.400

Default: 0.315

Softkey Location: **Mode > Bluetooth > Impairments > Mod Index**

Modulation Type

This key accesses a menu for selecting the modulation type. You may choose among various forms of PSK, MSK, FSK or QAM modulation types. This softkey is only available when **Multicarrier Off On** is toggled to **Off**.

Softkey Location: **Mode > Other Formats > Digital Mod Define > Modulation Type**

MSK

This key selects a minimum shift keying modulation. MSK modulation transmits data at the rate of 1 bit per symbol. When you select MSK, the modulation selection appears in the Mod Type field in the text area of the display. This softkey is only available when **Multicarrier Off On** is toggled to **Off**.

Softkey Location: **Mode > Other Formats > Digital Mod Define > Modulation Type > MSK**

MTONE

This key displays the multitone waveform files stored in the signal generator.

Softkey Location: **Utility > Memory Catalog > Catalog Type > ARB Catalog Types > MTONE**

Multicarrier Define

This key accesses the Multicarrier CDMA Setup or Digital Modulation Setup table, a table editor for defining a custom multicarrier signal. This softkey is grayed-out until you have enabled the Multicarrier Mode by pressing **Multicarrier Off On** until **On** is highlighted.

At signal generator preset, the default CDMA table lists three 9-channel forward carriers. The first carrier is at a frequency offset of -1.250000 MHz, the second carrier has no frequency offset, and the third carrier has a frequency offset of $+1.250000$ MHz. All three default carriers have a 0.00 dB relative power level.

At signal generator preset, the default Digital Modulation table lists two NADC carriers. The first carrier is at a frequency offset of -500 kHz, and the second carrier has a frequency offset of +500 kHz. Both default carriers have a 0.00 dB relative power level.

Using the Multicarrier Setup table, you can build a multicarrier signal using the available CDMA channel types (9-, 32-, and 64- channel forward, pilot, and reverse) or a custom CDMA carrier stored in the signal generator's memory.

Softkey Location: **Mode > CDMA Formats > IS-95A > Multicarrier Off On > Multicarrier Define**

Or: **Mode > Other Formats > Multicarrier Off On > Multicarrier Define**

Multicarrier Off On

This key turns the multicarrier mode off or on. In Multicarrier mode you can select many different types of pre-defined Digital Modulation or CDMA multicarrier signals, including user-defined custom multicarrier signals that can contain up to 12 carriers.

Default: Off

Softkey Location: **Mode > CDMA Formats > IS-95A > Multicarrier Off On**

Or: **Mode > Other Formats > Multicarrier Off On**

Multitone

This key accesses a menu of softkeys that enables you to create multitone signals using the multitone waveform generator. Within these menus, you will be able to create, select, and/or modify the waveform. See also "[Creating a Multitone Waveform](#)" on page 2-47.

Softkey Location: **Mode > Multitone**

Multitone Off On

This key turns the operating state of the multitone generator on or off.

Default: Off

Softkey Location: **Mode > Multitone > Multitone Off On**

NADC

This key selects a predefined North American Digital Cellular personality for the digital modulation format.

Softkey Location: **Mode > Other Formats > Setup Select > NADC**

Or: **Mode > Other Formats > Multicarrier Off On (until On is highlighted) > Multicarrier Define > Initialize Table > Carrier Setup > NADC**

Name And Store

This key stores and renames (if necessary) the highlighted sequence.

Softkey Location: **Mode > Dual ARB > Waveform Sequences > Build New Waveform Sequence > Name and Store**

Or: **Mode > Dual ARB > Waveform Sequences > Edit Selected Waveform Sequence > Name And Store**

Next PN Offset

This key displays the code domain power graph of the next pseudorandom noise offset when the setup contains more than one PN offset.

Softkey Location: **Mode > CDMA Formats > IS-95A > CDMA Define > Edit Channel Setup > Display Code Domain Power > Next PN Offset**

Noise Seed

This key enables you to set the noise seed for the Bluetooth AWGN waveform generator. Different noise seeds generate different noise waveforms.

Range: 1 through 65535

Default: 1

Softkey Location: **Mode > Bluetooth > Impairments > AWGN > Noise Seed**

Noise Seed Fixed Random

This key toggles the AWGN waveform generator noise seed to either a fixed value or a randomly generated value. Using a fixed seed will generate the same waveforms each time.

Default: Fixed

Softkey Location: **Mode > AWGN > Noise Seed Fixed Random**

None

This key selects no windowing to be applied to the generated user-defined filter.

Softkey Location: **Mode > Other Formats > Digital Mod Define > Filter > Define User FIR > Load Default FIR > Root Nyquist (or Nyquist, Gaussian, or Rectangle) > Window > None**

Number of Tones

This key enables you to set the number of tones in the multitone table editor. This is done as part of initializing the table editor. See “[Creating a Multitone Waveform](#)” on page 2-47 for details.

Range: 2 through 64

Default: 8

Softkey Location: **Mode > Multitone > Initialize Table > Number of Tones**

Nyquist

This key selects the Nyquist (raised cosine) pre-modulation filter in either the Select (filter) menu or the Load Default FIR menu.

In the Select (Filter) Menu

Pressing the Nyquist softkey selects this FIR filter for use in the filter setup.

Range: 0 through 1

Default Filter Alpha: 0.500

Softkey Location: **Mode > CDMA Formats > IS-95A > CDMA Define > Filter > Select > Nyquist**

Or: **Mode > Other Formats > Digital Mod Define > Filter > Select > Nyquist**

In the Load Default FIR Menu

Pressing the Nyquist softkey followed by **Generate** loads the FIR table editor with the coefficient values for the Nyquist filter. The filter alpha and number of filter symbols are defined with the softkeys in this menu. If you change either parameter after loading the filter coefficients, press the **Generate** softkey again to reload the FIR table.

The [Display Impulse Response](#) and [Display FFT](#) softkeys in this menu graphically display the filter as it is currently defined in the FIR table editor.

Softkey Location: **Mode > CDMA Formats > IS-95A > CDMA Define > Filter > Define User FIR > Load Default FIR > Nyquist**

Or: **Mode > Other Formats > Digital Mod Define > Filter > Define User FIR > Load Default FIR > Nyquist**

Optimize FIR For EVM ACP

This key optimizes the filter for minimized error vector magnitude (EVM) or to minimized adjacent channel power (ACP). The EVM selection provides the most ideal passband. The ACP selection improves stopband rejection. This feature only applies to Root Nyquist, Nyquist, and Gaussian filters. The softkey is grayed out when any other filter is selected.

Default: EVM

Softkey Location: **Mode** > **CDMA Formats** > **IS-95A** > **CDMA Define** > **Filter** > **Optimize For EVM ACP**

Or: **Mode** > **Other Formats** > **Digital Mod Define** > **Filter** > **Optimize For EVM ACP**

OQPSK

This key selects offset quadrature phase shift keying for modulating a continuous stream of the selected data pattern. OQPSK modulation transmits data at the rate of 2 bits per symbol. The modulation selection appears in the **Mod Type** field in the text area of the display, and under the **Modulation Type** softkey. This softkey is available only when **Multicarrier Off On** is toggled to **Off**.

Softkey Location: **Mode** > **Other Formats** > **Digital Mod Define** > **Modulation Type** > **PSK** > **QPSK and OQPSK** > **OQPSK**

Oversample Ratio

There are two **Oversample Ratio** softkeys.

In the CDMA Define Menu

This key enables you to set the oversampling ratio (number of filter coefficients per symbol) for CDMA modulation. Acceptable values range from 2 through 8. Using larger oversample ratios results in more completely filtered images but also uses up more waveform memory.

The upper limit of the oversample ratio is adjusted based on the waveform length and chip rate. The maximum oversample ratio is the smaller of the following three values:

- 40 Mcps/Chip Rate
- 8
- 32/Waveform Length (Note the Waveform Length is the number of CDMA short codes)

Default: 5

Softkey Location: **Mode > CDMA Formats > IS-95A > CDMA Define > Oversample Ratio**

In the Define User FIR Menu

This key enables you to set the oversampling ratio to be applied to a custom FIR filter design. Acceptable values range from 1 through 32, where the maximum combination of symbols and oversampling ratio is 1024 coefficients. An FIR filter selected for use in CDMA, however, cannot have more than 512 coefficients so the number of symbols and the oversample ratio should be selected accordingly.

Default: 4

Softkey Location: **Mode > CDMA Formats > IS-95A > CDMA Define > Filter > Define User FIR > Oversample Ratio**

Or: **Mode > Other Formats > Digital Mod Define > Filter > Define User FIR > Oversample Ratio**

Packet (DH1)

This key accesses the packet setup menu. A packet is a single bundle of information transmitted within a piconet. A DH1 packet covers a single timeslot.

Softkey Location: **Mode > Bluetooth > Packet (DH1)**

Page Down

This key enables you to view the next page of listings in a table editor or catalog of files.

Page Down is located in table editor menus and in catalogs of files.

Page Up

This key enables you to view the previous page of listings in a table editor or catalog of files.

Page Down is located in table editor menus and in catalogs of files.

Paging

This key enables you to insert a paging channel into the CDMA Channel Setup table.

Softkey Location: **Mode > CDMA Formats > IS-95A > CDMA Define > Edit Channel Setup > Insert Row > Paging**

Payload Data

This key accesses a menu from which you can select the payload data type. Payload data is the user's voice or data information that is carried in a packet. You can select from continuous PN9 (CPN9), truncated PN9 (TPN9), or create an 8-bit user defined pattern.

Default: TPN9

Softkey Location: **Mode** > **Bluetooth** > **Packet (DH1)** > **Payload Data**

PDC

This key selects a predefined Personal Digital Cellular personality for the digital modulation format.

Softkey Location: **Mode** > **Other Formats** > **Setup Select** > **PDC**

Or: **Mode** > **Other Formats** > **Multicarrier Off On** (until **On** is highlighted) > **Multicarrier Define** > **Initialize Table** > **Carrier Setup** > **PDC**

PHS

This key selects a predefined Personal Handy Phone System personality for the digital modulation format.

Softkey Location: **Mode** > **Other Formats** > **Setup Select** > **PHS**

Or: **Mode** > **Other Formats** > **Multicarrier Off On** (until **On** is highlighted) > **Multicarrier Define** > **Initialize Table** > **Carrier Setup** > **PHS**

Pilot (Setup Select)

This key appears in two places.

In the Setup Select Menu

This key selects a pilot channel for the CDMA setup.

The pilot channel carries pure short code, with no additional information content. It must be present in every station because it is both a demodulation reference for the mobile receivers and for handoff level measurements.

All stations use the same short code and therefore have the same pilot waveform. The pilot waveforms are distinguished from one another by variations in PN offset.

Softkey Location: **Mode** > **CDMA Formats** > **IS-95A** > **Setup Select** > **Pilot**

In the Channel Select Menu

This key inserts a pilot channel into the CDMA Channel Setup table Insert Row menu.

The pilot channel carries pure short code, with no additional information content. It must be present in every station because it is both a demodulation reference for the mobile receivers and for handoff level measurements.

All stations use the same short code and therefore have the same pilot waveform. The pilot waveforms are distinguished from one another by variations in PN offset.

Softkey Location: Mode > CDMA Formats > IS-95A > CDMA Define > Edit Channel Setup > Insert Row > Pilot

Plot CCDF

This key displays a plot of the complementary cumulative distribution function for the selected waveform. The plot displays the probability that the instantaneous envelope power is x dB above the average power, where x is the number on the horizontal axis.

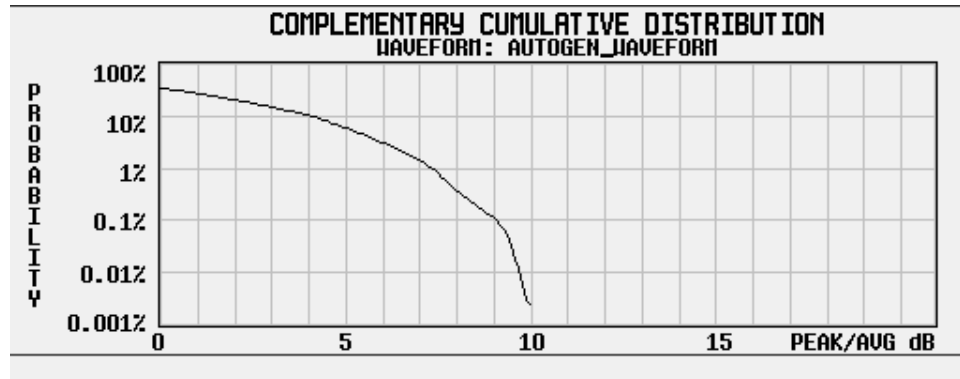

Softkey Location: Mode > AWGN > Waveform Statistics > Plot CCDF

Or: Mode > CDMA Formats > IS-95A > Waveform Statistics > Plot CCDF

Or: Mode > Dual ARB > Select Waveform > Waveform Segments > Waveform Statistics > Plot CCDF

Or: Mode > Multitone > Waveform Statistics > Plot CCDF

PN Offset

This key selects the PN offset as a column by which the table will be sorted.

Softkey Location: Mode > CDMA Formats > IS-95A > CDMA Define > Edit Channel Setup > Sort Table > Primary Key (or Secondary Key) > PN Offset

Previous PN Offset

This key displays the code domain power graph of the previous PN offset when the setup contains more than one PN offset.

Softkey Location: **Mode > CDMA Formats > IS-95A > CDMA Define > Edit Channel Setup > Display Code Domain Power > Previous PN Offset**

Primary Key

This key selects the primary column used to sort the table. The choices are Walsh code or PN offset.

NOTE

Primary and secondary key choices must be different.

Softkey Location: **Mode > CDMA Formats > IS-95A > CDMA Define > Edit Channel Setup > Sort Table > Primary Key**

PSK

This key accesses a menu of phase shift keying modulation types.

This softkey is only available when **Multicarrier Off On** is toggled to **Off**.

Softkey Location: **Mode > Other Formats > Digital Mod Define > Modulation Type > PSK**

PWT

This key selects a predefined personal wireless telephone personality for the digital modulation format. The PWT standard is an adaptation of the DECT air-interface with a $\pi/4$ DQPSK modulation to reduce radio channel bandwidth.

Softkey Location: **Mode > Other Formats > Setup Select > PWT**

Or: **Mode > Other Formats > Multicarrier Off On > Multicarrier Define > Initialize Table > Carrier Setup > PWT**

QAM

This key accesses a menu of quadrature amplitude modulation types.

This softkey is only available when **Multicarrier Off On** is toggled to **Off**.

Softkey Location: **Mode > Other Formats > Digital Mod Define > Modulation Type > QAM**

QPSK

This key selects a quadrature phase shift keying modulation. QPSK modulation transmits data at the rate of 2 bits per symbol. The modulation selection appears in the `Mod Type` field in the text area of the display, and under **Modulation Type** softkey. This softkey is only available when **Multicarrier Off On** is toggled to **Off**.

Softkey Location: **Mode > Other Formats > Digital Mod Define > Modulation Type > PSK > QPSK and OQPSK > QPSK**

QPSK and OQPSK

This key accesses a menu of quadrature phase shift keying and offset quadrature phase shift keying modulation types. QPSK and OQPSK modulations transmit data at the rate of 2 bits per symbol. You can choose from QPSK, IS95 QPSK, Gray Coded QPSK, OQPSK, and IS95 OQPSK. This softkey is only available when **Multicarrier Off On** is toggled to **Off**.

Softkey Location: **Mode > Other Formats > Digital Mod Define > Modulation Type > PSK > QPSK and OQPSK**

Random

This key selects random data as the CDMA channel data type.

Softkey Location: **Mode > CDMA Formats > IS-95A > CDMA Define > Edit Channel Setup > Edit Item > Random**

Default: Random

Random Seed Fixed Random

This key toggles between either a fixed seed or a random seed for the randomly generated phases of the multitone table editor tones. This is done as part of initializing the multitone table editor. Selecting **Fixed** will generate the same random phases after each initialization. Selecting **Random** will generate new phases after each initialization. These softkey selections are used when the **Initialize Phase Fixed Random** softkey is set to the **Random** selection.

Default: Fixed

Softkey Location: **Mode > Multitone > Initialize Table > Random Seed Fixed Random**

Reconstruction Filter

This key accesses a menu from which you can select a reconstruction filter. You can choose a filter with a cutoff frequency of 250.0 kHz, 2.500 MHz, 8.000 MHz or no filter (Through).

Default: 2.500 MHz

Softkey Location: **Mode > CDMA Formats > IS-95A > CDMA Define > Reconstruction Filter**

Or: **Mode > Dual ARB > ARB Setup > Reconstruction Filter**

Rectangle

This key selects a rectangle pre-modulation filter in either the Select (filter) menu or the Load Default FIR menu.

In the Select (Filter) Menu

Pressing the **Rectangle** softkey selects this FIR filter for use in your filter setup.

Softkey Location: **Mode > CDMA Formats > IS-95A > CDMA Define > Filter > Select > Rectangle**

Or: **Mode > Other Formats > Digital Mod Define > Filter > Select > Rectangle**

In the Load Default FIR Menu

Pressing the **Rectangle** softkey followed by **Generate** loads the FIR table editor with the coefficient values for a rectangle filter.

The [Display Impulse Response](#) and [Display FFT](#) softkeys in this menu graphically display the filter as it is currently defined in the FIR table editor.

Softkey Location: **Mode > CDMA Formats > IS-95A > CDMA Define > Filter > Define User FIR > Load Default FIR > Rectangle**

Or: **Mode > Other Formats > Digital Mod Define > Filter > Define User FIR > Load Default FIR > Rectangle**

Reference Freq

This key enables you to set the reference frequency of the external clock. It is only available when you are using an external ARB reference applied to the BASEBAND GEN REF IN connector.

Range: 250.0000 kHz to 20.0000000 MHz

Default: 10.0000000 MHz

Softkey Location: **Mode > CDMA Formats > IS-95A > CDMA Define > Reference Freq**

Or: **Mode > Dual ARB > ARB Setup > Reference Freq**

Rename Segment

This key enables you to rename the selected waveform segment in the displayed catalog.

Softkey Location: **Mode > Dual ARB > Waveform Segments > Rename Segment**

Restore Default Filter

This key replaces the current FIR filter with the default filter (IS-95 Mod w/EQ for CDMA formats or Root Nyquist for digital modulation formats).

Softkey Location: **Mode > CDMA Formats > IS-95A > CDMA Define > Filter > Restore Default Filter**

Or: **Mode > Other Formats > Digital Mod Define > Filter > Restore Default Filter**

Retrigger Mode Off On

This key toggles the operating state of the retrigger mode between on or off. With **Retrigger Mode Off On** set to **On**, if a trigger occurs while a waveform is playing, the waveform will retrigger at the end and play one more time. The retriggers do not accumulate. If several triggers are received during a waveform, it will only be replayed once. When **Retrigger Mode Off On** is set to **Off**, if a trigger occurs while a waveform is playing, it is ignored.

NOTE

For trigger availability information, see the **Trigger** softkey definition.

Default: **On**

Softkey Location: **Mode > CDMA Formats > IS-95A > Trigger > Trigger Setup > Retrigger Mode Off On**

Or: **Mode > Dual ARB > Trigger > Trigger Setup > Retrigger Mode Off On**

Or: **Mode > Other Formats > Trigger > Trigger Setup > Retrigger Mode Off On**

Reverse

This key selects a reverse traffic channel for the CDMA setup.

Softkey Location: **Mode** > **CDMA Formats** > **IS-95A** > **Setup Select** > **Reverse**

In the Load Default FIR menu, pressing the **Root Nyquist** softkey followed by **Generate** loads the FIR table editor with the coefficient values for the Root Nyquist filter. The filter alpha and number of filter symbols are defined with the softkeys in this menu. If you change either parameter after loading the filter coefficients, press the **Generate** softkey again to reload the FIR table.

The **Display Impulse Response** and **Display FFT** softkeys in this menu graphically display the filter as it is currently defined in the FIR table editor.

Softkey Location: **Mode** > **CDMA Formats** > **IS-95A** > **CDMA Define** > **Filter** > **Define User FIR** > **Load Default FIR** > **Root Nyquist**

Root Nyquist

This key selects the Root Nyquist (root raised cosine) pre-modulation filter in either the Select (filter) menu or the Load Default FIR menu.

In the Select (Filter) Menu

Pressing the **Root Nyquist** softkey selects this FIR filter and returns the Filter menu.

Range: 0 through 1

Default (Alpha Value): 0.500

Softkey Location: **Mode** > **CDMA Formats** > **IS-95A** > **CDMA Define** > **Filter** > **Select** > **Root Nyquist**

Or: **Mode** > **Other Formats** > **Digital Mod Define** > **Filter** > **Select** > **Root Nyquist**

In the Load Default FIR Menu

Pressing the **Root Nyquist** softkey followed by **Generate** loads the FIR table editor with the coefficient values for the Root Nyquist filter. The filter alpha and number of filter symbols are defined with the softkeys in this menu. If you change either parameter after loading the filter coefficients, press the **Generate** softkey again to reload the FIR table.

The **Display Impulse Response** and **Display FFT** softkeys in this menu graphically display the filter as it is currently defined in the FIR table editor.

Softkey Location: **Mode > CDMA Formats > IS-95A > CDMA Define > Filter > Define User FIR > Load Default FIR > Root Nyquist**

Or: **Mode > Other Formats > Digital Mod Define > Filter > Define User FIR > Load Default FIR > Root Nyquist**

Scale To 0dB

This key scales all of the current channel powers so that the total power equals 0 dB while maintaining the previous power ratios between the individual channels.

Softkey Location: **Mode > CDMA Formats > IS-95A > CDMA Define > Edit Channel Setup > Adjust Code Domain Power > Scale to 0db**

Scaling

This key changes the scaling percentage of the selected waveform segment. You can set the scaling percentage to a resolution of 0.01% within the specified range. After entering the desired scaling percentage, terminate the entry with the % softkey.

Default: 100.00%

Range: 1.00% through 100.00%

Softkey Location: **Mode > Dual ARB > Waveform Segments > Waveform Utilities > Set Scaling > Scaling**

Secondary Key

This key selects the secondary column by which the table will be sorted. The choices are Walsh code or PN offset.

NOTE Primary and secondary key choices must be different.

Softkey Location: **Mode > CDMA Formats > IS-95A > CDMA Define > Edit Channel Setup > Sort Table > Secondary Key**

Segment Advance

This key selects segment advance as the dual ARB trigger type. After receiving a trigger while operating with a waveform sequence, the sequencer will play the next segment in the sequence.

NOTE For trigger availability information, see the **Trigger** softkey definition.

Softkey Location: **Mode > Dual ARB > Trigger > Segment Advance**

Select

Press this softkey to access a menu for selecting the pre-modulation filter type. You can choose from:

- Pre-defined filters, such as Root Nyquist, Nyquist, Gaussian, several IS-95 baseband filters, and Rectangle. When you access this menu through the wideband CDMA menus, a filter optimized for WCDM is also available.

The standard IS-95 filter is available as well as a modified version of this filter that meets the IS-95 error function for improved adjacent channel performance. These two filters are also provided with an equalizer for phase compensation required by the base station.

- A catalog of files stored in the signal generator memory. You can select any filter that you have either created externally and downloaded into memory, or that you have created internally in the Define User FIR menu and subsequently stored.

Default: Root Nyquist

Softkey Location: **Mode > CDMA Formats > IS-95A > CDMA Define > Filter > Select**

Or: **Mode > Other Formats > Digital Mod Define > Filter > Select**

Select File

This key enables you to select a stored file.

Select File is located in catalogs of files.

Select Waveform

This key accesses a list of files that can be selected for the Dual ARB to play.

Softkey Location: **Mode > Dual ARB > Select Waveform**

Select Waveform (ARBI: *or* SEQ:)

This key enables you to select the type of signal for the dual arbitrary waveform generator to generate. Choose between the waveform segment (ARBI:) or sequence file (SEQ:). Note that the name of the segment (ARBI:) or sequence (SEQ:) will follow after ARBI: or SEQ: in the softkey name.

Softkey Location: **Mode > Dual ARB > Select Waveform > Select Waveform (ARBI:/SEQ:)**

Set Marker Off All Points

This key clears the active marker (1 or 2) from all waveform points.

Softkey Location: **Mode > Dual ARB > Waveform Segments > Waveform Utilities > Set Markers > Set Marker Off All Points**

Or: **Mode > Dual ARB > Select Waveform > Waveform Segments > Waveform Utilities > Set Markers > Set Marker Off All Point**

Or: **Mode > Dual ARB > Waveform Sequence > Build New Waveform Sequence > Insert Waveform > Waveform Segments > Waveform Utilities > Set Markers > Set Marker Off All Point**

Or: **Mode > Dual ARB > Waveform Sequence > Edit Selected Waveform Sequence > Insert Waveform > Waveform Segments > Waveform Utilities > Set Markers > Set Marker Off All Point**

Set Marker Off Range of Points

This key accesses a menu from which you can clear the active marker from a range of points on the selected waveform.

Softkey Location: **Mode > Dual ARB > Waveform Segments > Waveform Utilities > Set Markers > Set Marker Off Range of Points**

Or: **Mode > Dual ARB > Select Waveform > Waveform Segments > Waveform Utilities > Set Markers > Set Marker Off Range of Points**

Or: **Mode > Dual ARB > Waveform Sequence > Build New Waveform Sequence > Insert Waveform > Waveform Segments > Waveform Utilities > Set Markers > Set Marker Off Range of Points**

Or: **Mode > Dual ARB > Waveform Sequence > Edit Selected Waveform Sequence > Insert Waveform > Waveform Segments > Waveform Utilities > Set Markers > Set Marker Off Range of Points**

Set Marker On First Point

This key turns on the active marker on the first point of the selected waveform.

Softkey Location: **Mode > Dual ARB > Waveform Segments > Waveform Utilities > Set Markers > Set Marker On First Point**

Or: **Mode > Dual ARB > Select Waveform > Waveform Segments > Waveform Utilities > Set Markers > Set Marker On First Point**

Or: **Mode > Dual ARB > Waveform Sequence > Build New Waveform Sequence > Insert Waveform > Waveform Segments > Waveform Utilities > Set Markers > Set Marker On First Point**

Or: Mode > Dual ARB > Waveform Sequence >
Edit Selected Waveform Sequence > Insert Waveform > Waveform Segments >
Waveform Utilities > Set Markers > Set Marker On First Point

Set Marker On Range of Points

This key displays a menu in which you can set the active marker over a range of points on the selected waveform.

Softkey Location: Mode > Dual ARB > Waveform Segments >
Waveform Utilities > Set Markers > Set Marker On Range of Points

Or: Mode > Dual ARB > Select Waveform > Waveform Segments >
Waveform Utilities > Set Markers > Set Marker On Range of Points

Or: Mode > Dual ARB > Waveform Sequence > Build New Waveform Sequence >
Insert Waveform > Waveform Segments > Waveform Utilities > Set Markers >
Set Marker On Range of Points

Or: Mode > Dual ARB > Waveform Sequence >
Edit Selected Waveform Sequence > Insert Waveform > Waveform Segments >
Waveform Utilities > Set Markers > Set Marker On Range of Points

Set Markers

This key displays a menu that enables you to set waveform markers. This softkey is not available unless a waveform segment is selected. See [“Waveform Segments”](#) on page 3-74.

Softkey Location: Mode > Dual ARB > Waveform Segments >
Waveform Utilities > Set Markers

Or: Mode > Dual ARB > Select Waveform > Waveform Segments >
Waveform Utilities > Set Markers

Or: Mode > Dual ARB > Waveform Sequence > Build New Waveform Sequence >
Insert Waveform > Waveform Segments > Waveform Utilities > Set Markers

Or: Mode > Dual ARB > Waveform Sequence >
Edit Selected Waveform Sequence > Insert Waveform > Waveform Segments >
Waveform Utilities > Set Markers

Set Scaling

This key enables you to change the peak-to-peak output value of a selected waveform segment to a desired percentage of its full-scale value. This scaling of the waveform segment can be used to reduce distortion or to set the amplitude output at the rear-panel I-OUT and Q-OUT connectors. The scaling can be set from 1% to 100% with a resolution of 0.01%. This softkey is not available unless a waveform segment is selected. See [“Waveform Segments”](#) on page 3-74.

NOTE As the waveform segment is scaled down, resolution is lost proportionate to the percentage that the waveform is scaled. Once this resolution is lost, it is not regained by increasing the scaled percentage.

Softkey Location: **Mode > Dual ARB > Waveform Segments > Waveform Utilities > Set Scaling**

Setup Select

This key accesses a menu for defining the type of Digital Modulation, CDMA, or Multicarrier CDMA channelization required for your application. To access the Multicarrier CDMA setup, **Multicarrier Off On** must be set to **On**.

The CDMA choices include:

- Pilot - a single pilot channel.
- 9 Channel Forward - a CDMA setup consisting of 9 channels (including pilot, paging, sync, and 6 traffic channels) at IS-97-defined power levels.
- 32 Channel Forward - a CDMA setup consisting of 32 channels (including pilot, paging, sync, and 29 traffic channels) at IS-97-defined power levels.
- 64 Channel Forward - a CDMA setup consisting of 64 channels (including pilot, 7 paging, sync, and 55 traffic channels) at IS-97-defined power levels.
- Reverse - a single traffic channel.
- Custom CDMA State - a user-defined CDMA state file previously stored in the signal generator's non-volatile memory.

The Multicarrier CDMA choices include:

- 3 Carriers - Three 9 channel forward carriers at power levels of 0.00 dB. The first carrier has a frequency offset of -1.25 MHz, the second carrier has no frequency offset, and the third carrier has a frequency offset of $+1.25$ MHz.
- 4 Carriers - Four 9 channel forward carriers at power levels of 0.00 dB. The first carrier has a frequency offset of -1.875 MHz, the second carrier has a frequency offset of -625 kHz, the third carrier has a frequency offset of $+625$ kHz, and the fourth carrier has a frequency offset of $+1.875$ MHz.

- Custom CDMA Carrier - a custom multicarrier CDMA setup defined by the user and stored in the signal generator's MCDMA memory catalog.

Default: 9 Ch Fwd

Softkey Location: **Mode > CDMA Formats > IS-95A > Setup Select**

Or: **Mode > Other Formats > Setup Select**

Show Waveform Sequence Contents

This key displays the contents of the selected waveform sequence in a table format. The content information displayed is a list of the waveforms and corresponding repetitions for that sequence. Note that this softkey is only present when a sequence is highlighted.

Softkey Location: **Mode > Dual ARB > Select Waveform > Show Waveform Sequence Contents**

Or: **Mode > Dual ARB > Waveform Sequences > Build New Waveform Sequence > Insert Waveform > Show Waveform Sequence Contents**

Or: **Mode > Dual ARB > Waveform Sequences > Edit Selected Waveform Sequence > Insert Waveform > Show Waveform Sequence Contents**

Single

This key sets the trigger type to single. After receiving a trigger, the waveform is output once.

NOTE

For trigger availability information, see the **Trigger** softkey definition.

Softkey Location: **Mode > CDMA Formats > IS-95A > Trigger > Single**

Or: **Mode > Dual ARB > Trigger > Single**

Or: **Mode > Other Formats > Trigger > Single**

Sort

This key sorts the CDMA channel table editor by the selected primary and secondary keys.

Softkey Location: **Mode > CDMA Formats > IS-95A > CDMA Define > Edit Channel Setup > Sort Table > Sort**

Sort Table

This key accesses a menu where you can sort the table editor files by selecting primary and secondary keys. The keys are columns of the table. The choices are Walsh code or PN offset.

Softkey Location: **Mode > CDMA Formats > IS-95A > CDMA Define > Edit Channel Setup > Sort Table**

Store All

This key moves all of the files from or currently stored in (volatile) ARB memory to (non-volatile) NVARB memory for later recall and use.

Softkey Location: **Mode > Dual ARB > Select Waveform > Waveform Segments > Store All**

Store Custom CDMA State

This key accesses a menu that enables you to store the current custom CDMA state into a user-defined file. Afterward, you can recall this custom state from the signal generator's memory (as described under the softkey [Custom CDMA State](#)).

Along with the contents of the CDMA channel table editor (channel types, Walsh code, power levels, PN offset, and data), this softkey stores the following signal generator state information to the memory catalog:

- FIR filter
- FIR filter file name
- FIR filter alpha
- FIR filter BbT
- FIR filter channel (EVM or ACP)
- chip rate
- waveform length
- oversample ratio
- ARB reconstruction filter
- ARB reference clock source (internal or external)
- ARB reference clock frequency

Softkey Location: **Mode > CDMA Formats > IS-95A > CDMA Define > Store Custom CDMA State**

Store Custom Dig Mod State

This key accesses a menu that enables you to store the current custom digital modulation state into a user-defined file. Afterward, you can recall this custom state from the signal generator's memory (as described under the softkey **Custom Digital Mod State**). This softkey is only available when **Multicarrier Off On** is toggled to **Off**.

This softkey stores the following signal generator state information to the memory catalog:

- filter information
- symbol rate
- modulation type
- FSK deviation

Softkey Location: **Mode > Other Formats > Digital Mod Define > Store Custom Digital Mod State**

Store Custom Multicarrier

This key accesses a menu that enables you to store the current changes to the default multicarrier setup into the file you enter. Afterward, you can recall these custom multicarrier settings from the signal generator's memory by pressing **Mode > CDMA Formats > IS-95A > Setup Select > Custom CDMA Carrier** and selecting the appropriate file.

This softkey stores the following instrument state information to the memory catalog:

- type of carriers
- frequency offset for each carrier
- power level for each carrier
- the number of different carriers

Softkey Location: **Mode > CDMA Formats > IS-95A > Multicarrier Off On > Multicarrier Define > Store Custom Multicarrier**

Store Segment

This key stores the selected file from (volatile) ARB memory to (non-volatile) NVARB memory for later recall and use.

Softkey Location: **Mode > Dual ARB > Select Waveform > Waveform Segments > Store Segmen10**

Store To File

This key displays a menu where you can store the current table editor information for later use.

Store To File is located in catalogs of files.

Symbol Rate

This key enables you to set a new symbol rate value. This softkey is only available when **Multicarrier Off On** is toggled to **Off**.

Range: 1 ksps to 12.5 Msps

Defaults:

Custom, NADC:	24.300 ksps
PDC:	21.000 ksps
DECT:	1.152000 Msps
PHS:	192.000 ksps
EDGE and GSM:	270.833 ksps
TETRA:	18.000 ksps
APCO 25 w/C4FM, APCO 25 w/CQPSK:	4.800 ksps
CDPD:	19.200 ksps
PWT:	576.000 ksps

Softkey Location: **Mode > Other Formats > Digital Mod Define > Symbol Rate**

Symbol Timing Err

This key enables you to set a symbol timing error in either parts per million (ppm) or hertz (Hz). The sample rate of the arbitrary waveform generator shifts to generate the symbol timing error. A 20 ppm timing error corresponds to a 20 Hz shift in the symbol rate.

Range: -50 ppm through 50 ppm

Default: 0

Softkey Location: **Mode** > Bluetooth > Impairments > Symbol Timing Err

Sync

This key enables you to insert a synchronization channel into the CDMA Channel Setup table.

Softkey Location: **Mode** > CDMA Formats > IS-95A > CDMA Define > Edit Channel Setup > Insert Row > Sync

TETRA

This key selects a predefined Trans European Trunked Radio personality for the digital modulation format.

Softkey Location: **Mode** > Other Formats > Setup Select > TETRA

Or: **Mode** > Other Formats > Multicarrier Off On > Multicarrier Define > Initialize Table > Carrier Setup > TETRA

Through

This key bypasses all reconstruction filtering. This is useful for using external reconstruction filters at frequencies different than those supplied internally.

Softkey Location: **Mode** > CDMA Formats > IS-95A > CDMA Define > Reconstruction Filter > Through

Or: **Mode** > Dual ARB > ARB Setup > Reconstruction Filter > Through

Toggle Marker 1

This toggle key enables/disables marker1 for the selected segment of a waveform sequence.

Default: Off

Softkey Location: **Mode** > Dual ARB > Waveform Sequence > Build New Waveform Sequence > Toggle Markers > Toggle Marker 1

Toggle Marker 2

This toggle key enables/disables marker 2 for the selected segment of a waveform sequence.

Default: Off

Softkey Location: **Mode > Dual ARB > Waveform Sequence > Build New Waveform Sequence > Toggle Markers > Toggle Marker 2**

Toggle Markers

This key displays a menu where you can toggle markers 1 and 2 to enable or disable markers for selected segments of a sequence.

Softkey Location: **Mode > Dual ARB > Waveform Sequence > Build New Waveform Sequence > Toggle Markers**

Toggle State

In the multitone editor, this key enables you to turn the selected tone on and off. This determines whether or not a tone is generated.

Default: On

Softkey Location: **Mode > Multitone > Toggle State**

Traffic

This key inserts a traffic channel into the CDMA Channel Setup table.

Softkey Location: **Mode > CDMA Formats > IS-95A > CDMA Define > Edit Channel Setup > Insert Row > Traffic**

Trigger

This key displays the trigger menu, from which you can select types of triggering. The menu also contains a **Trigger Setup** key that enables you to adjust the trigger source, the retrigger mode and the gate active polarity.

NOTE

Dual ARB triggers and their associated softkeys and SCPI functionality became available in signal generators with serial number prefix US3844 or GB3845. Dual ARB triggers are *not* available in signal generators with an earlier serial number prefix, unless upgraded.

To upgrade your signal generator to include Dual ARB triggering, contact your nearest Agilent Technologies Sales and Service office.

Default: Continuous

Softkey Location: **Mode > CDMA Formats > IS-95A > Trigger**

Or: **Mode > Dual ARB > Trigger**

Or: **Mode > Other Formats > Trigger**

Trigger Key

This key sets the trigger source to the signal generator's front-panel **Trigger** hardkey. When the trigger source is set to **Trigger Key**, the signal generator will trigger an event when the **Trigger** hardkey is pressed.

NOTE

For trigger availability information, see the **Trigger** softkey definition.

Softkey Location: **Mode > CDMA Formats > IS-95A > Trigger > Trigger Setup > Trigger Source > Trigger Key**

Or: **Mode > Dual ARB > Trigger > Trigger Setup > Trigger Source > Trigger Key**

Or: **Mode > Other Formats > Trigger > Trigger Setup > Trigger Source > Trigger Key**

Trigger Setup

This key displays the dual setup menu. This menu enables you to adjust the trigger source, the retrigger mode and the gate active polarity.

NOTE

For trigger availability information, see the **Trigger** softkey definition.

Softkey Location: **Mode > CDMA Formats > IS-95A > Trigger > Trigger Setup**

Or: **Mode > Dual ARB > Trigger > Trigger Setup**

Or: **Mode > Other Formats > Trigger > Trigger Setup**

Trigger Source

This key displays the trigger source menu. This menu enables you to adjust the trigger source between the front panel **Trigger** key, a trigger command sent over the GPIB bus, or an external trigger applied to the PATTERN TRIG IN connector.

NOTE

For trigger availability information, see the **Trigger** softkey definition.

Default: **Ext**

Softkey Location: **Mode > CDMA Formats > IS-95A > Trigger > Trigger Source**

Or: **Mode > Dual ARB > Trigger > Trigger Source**

Or: **Mode > Other Formats > Trigger > Trigger Source**

Truncated PN9

This key enters a truncated PN9 pattern in a Bluetooth setup. The truncated PN9 places the first 216 bits of a PN9 sequence into one packet of a single-packet signal.

Softkey Location: **Mode** > **Bluetooth** > **Packet** > **Payload Data** > **Truncated PN9**

User FIR

This key displays the catalog of FIR filter files stored in the signal generator's memory. You can select a custom filter from this catalog for your pre-modulation filter. Scroll through the listed files and when your selection is highlighted, press the **Select File** softkey. Notice that **User File** is shown in the **Data** field of the display as well as in the second line of the **Select** softkey.

Softkey Location: **Mode** > **CDMA Formats** > **IS-95A** > **CDMA Define** > **Filter** > **Select** > **User FIR**

Or: **Mode** > **Other Formats** > **Digital Mod Define** > **Filter** > **Select** > **User FIR**

Walsh Code

This key selects the Walsh code as a column by which the table will be sorted.

Softkey Location: **Mode** > **CDMA Formats** > **IS-95A** > **CDMA Define** > **Edit Channel Setup** > **Sort Table** > **Primary Key OR Secondary Key** > **Walsh Code**

Waveform Length

For AWGN

This key opens a menu of waveform length choices; the longer the waveform, the better the statistics (at the expense of memory usage).

Default: 524288

Softkey Location: **Mode** > **AWGN** > **Waveform Length**

For CDMA

This key adjusts the waveform length (in short codes). The upper limit is adjusted based on the oversample ratio to fit the signal within the available memory.

Range: 1 through 16

Default: 1

Softkey Location: **Mode** > **CDMA Formats** > **IS-95A** > **CDMA Define** > **Waveform Length**

Waveform Segments

This key opens a menu and table editor where you can store and load waveform segments to or from the non-volatile waveform memory (NVARB).

Until a waveform is selected, two of the softkeys in this menu are grayed out:

- [Set Markers](#) Select
- Waveform Statistics

Softkey Location: **Mode > Dual ARB > Waveform Segments**

Or: **Mode > Dual ARB > Select Waveform > Waveform Segments**

Waveform Sequences

This key accesses a menu and table editor where you can build waveform sequences, edit existing sequences, and/or delete sequences.

Softkey Location: **Mode > Dual ARB > Waveform Sequences**

Waveform Statistics

This key displays the Waveform Statistics Menu. When this softkey is active, statistics are available for the selected waveform. To activate the key, make sure that the selected Dual Arb Generator option (such as, AWGN, Multitone, Digital Modulation, and so on) is turned on.

Softkey Location: **Mode > AWGN > Waveform Statistics**

Or: **Mode > CDMA Formats > IS-95A > Waveform Statistics**

Or: **Mode > Dual ARB > Waveform Segments > Waveform Statistics**

Or: **Mode > Multitone > Waveform Statistics**

Or: **Mode > Other Formats > Waveform Statistics**

Waveform Utilities

This key accesses a menu of operations that can be applied to the selected waveform segment. The waveform segment must be selected from volatile ARB memory, otherwise this softkey is inactive (grayed out). Waveform utilities include: markers, scaling, and clipping.

Softkey Location: **Mode > Dual ARB > Waveform Segments > Waveform Utilities**

Or: **Mode > Dual ARB > Select Waveform > Waveform Segments > Waveform Utilities**

WCDMA

This key selects the standard wideband code domain multiple access filter. This is a Nyquist filter with an alpha of 0.22 optimized for adjacent channel performance. This softkey is only available when **Multicarrier Off On** is toggled to **Off**.

Softkey Location: **Mode > Other Formats > Digital Mod Define > Filter > Select > WCDMA**

Or: **Mode > CDMA Formats > IS-95A > CDMA Define > Filter > Select > WCDMA**

Window

This key displays a menu from which you can select the window to apply to the generated filter.

This softkey is only available when **Multicarrier Off On** is toggled to **Off**.

Default: None

Softkey Location: **Mode > Other Formats > Digital Mod Define > Filter > Define User FIR > Load Default FIR > Root Nyquist (Nyquist, Gaussian, or Rectangle) > Window**

4 Operation

This section contains detailed information that will help you learn how to operate the dual arbitrary waveform generator section of your signal generator.

RF Modulation with Option UND

The basic modulation of digital data in signal generators with Option UND, from memory to RF output, occurs through the path shown in Figure 4-1, and described below.

Figure 4-1 ESG-D and ESG-DP Series Option UND Modulation Block Diagram

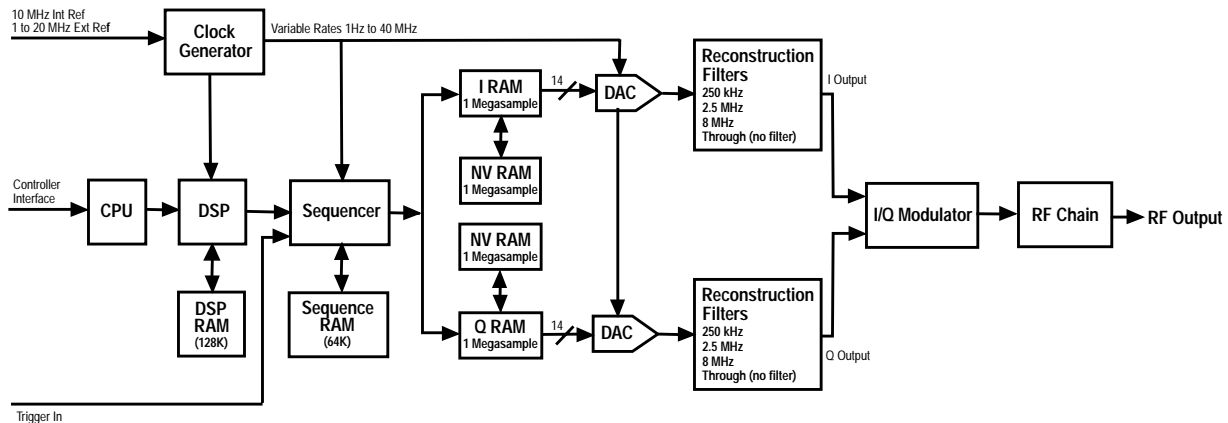

Clock Generator

The arbitrary waveform generator sample clock features variable rates between 1 Hz and 40 MHz. The sample clock can be referenced to the internal 10 MHz reference frequency or to external reference signal between 1 and 20 MHz applied to the EXT REF IN connector.

Sequencer

You can control the sequencer using a table editor, save different waveforms as separate segments, and sequence segments to create a chain of repeating waveform types. You can also use the sequencer to control markers on the waveform segments.

I RAM, Q RAM, and Nonvolatile RAM

I RAM and Q RAM each provide memory for 1 Megasample of data that you can clock to the DACs to modulate the RF carrier. You can store data to the 1 Megasample nonvolatile RAM and load it back into I RAM and Q RAM for subsequent playback.

Digital-to-Analog Converter and Filtering Hardware

14-bit DACs are used for superior fidelity. Reconstruction filters (250 kHz, 2.5 MHz, and 8 MHz) are provided, as well as a “through” filter which bypasses the internal filtering so that an external filter is applied.

I/Q Modulator

The I/Q modulator supplies the modulating signal to the RF hardware.

RF Hardware

The RF hardware produces the carrier signal and modulates it with the I/Q modulator.

Managing Volatile and Non-Volatile ARB Memory

Follow the guidelines in this section to learn how to manage the signal generator's volatile and non-volatile ARB memory. (Option UND is required.)

Understanding Arbitrary Waveform Memory Types

There are two types of arbitrary waveform generator memory: volatile, referred to as ARB memory, and non-volatile, referred to as NVARB memory.

Waveform data stored in ARB memory is volatile. The data in ARB memory is destroyed whenever the signal generator's line power is cycled. In ARB memory, waveform data may be downloaded, sequenced, and played back through the signal generator's I/Q baseband generator section.

Information stored in NVARB memory is non-volatile. Waveforms stored in NVARB memory must first be moved to ARB memory in order to be sequenced and played. Waveform data stored in NVARB memory is not at risk when the signal generator's line power is cycled.

While waveforms may be directly downloaded to either ARB or NVARB memory, it may be faster, if memory space permits, to first download the waveform data to ARB memory and then store it in NVARB memory. Downloads into ARB memory are significantly faster than downloads into NVARB memory. For additional information, see the section titled [“Downloading Waveform Files Into Memory”](#) on page 2-72.

Arbitrary Waveform Memory and CDMA Format Relationships

Other arbitrary waveform generator formats, such as CDMA and Wideband CDMA, use the same memory space as the waveform files downloaded for use by the dual arbitrary waveform generator. These formats all use the same file, `AUTOGEN_WAVEFORM`. You may increase memory space for waveform files by turning off the formats that are not being used and deleting the file `AUTOGEN_WAVEFORM`.

Understanding Volatile ARB Waveform Memory

Volatile waveform memory space is allocated in 4096-point (8192 byte) segments. Accordingly, regardless of how small the waveform is, it will always occupy at least 4096 points (8192 bytes) of volatile ARB memory. If a waveform file is too large to fit into a 4096-point memory segment, then additional memory space is allocated in multiples of 4096 points. For instance, if a waveform consists of 4100 points, it will be allocated to a 8192-point memory segment.

When played back through the sequencer, smaller waveforms will only play back the number of points occupied by their waveform data, not the full 4096 points. See the following table.

Table 4-1 Waveform Size Versus Memory Catalog File Size

Waveform	Number of Points	Memory Space (in points)
wfm1	32	4096
wfm2	128	4096
wfm3	4096	4096
wfm4	4098	8192
TOTAL POINTS	8354	20480

It is important to remember that, if there are lots of small waveform files stored in volatile ARB memory, the total memory usage may be much more than the sum of the points that make up the actual waveform data. There will not be as much memory available as perhaps expected, based on the combined sum of the individual waveform data files.

Waveform Composition

Dual ARB waveforms are composed of two sets of data: I and Q. The I data drives the I port of the I/Q modulator and the Q data drives the Q port. These two sets of data give rise to the name *dual* arbitrary waveform generator.

I and Q data are arrays of 2-byte integers. The actual waveform shape is enclosed in the least-significant 14 bits of both the I and Q data. The other four bits (two for I and two for Q) are used for event markers and internal sequencing.

Table 4-2 I and Q Bit Delegation

Bit Number	I	Q
0 through 13	waveform data	waveform data
14	EVENT 2	reserved
15	EVENT 1	reserved

A 1 in bit position 14 or 15 of the I data will cause a TTL high to appear at the associated EVENT BNC connector on the signal generator's rear panel.

The waveform data (bits 0 through 13) is in unsigned, offset format:

- 0 gives negative full-scale output
- 8192 gives 0V output
- 16383 gives positive full-scale output

Event Markers and Sequencing

As mentioned earlier, markers can be made available at the EVENT 1 and EVENT 2 connectors on the signal generator's rear panel. Waveform segments played individually will pass these markers to the associated output connector. However, when a segment is played as part of a sequence, the sequencer masks certain EVENT 1 markers. EVENT 2 markers are always played.

The sequencer will play the EVENT 1 marker for the first segment listed in a sequence. Subsequent waveform segments will have their EVENT 1 markers disabled. This means during a sequence playback where the first waveform segment has multiple repetitions, the markers for each segment repetition will be played until the sequencer moves on to the next listed waveform segment.

With Option UN5 CDMA turned on (Option UN5 requires Option UND hardware), an even second output is generated at the EVENT 1 connector. A marker is output every two seconds indicating the beginning of every 75th short code sequence for use in synchronizing CDMA analysis instruments.

For additional information on marker functionality, see [“Using Markers”](#) on page 2-61.

Waveform Limitations

There are several parameters that your waveform files must meet in order to work correctly:

1. Each I and Q waveform must have at least 16 points (a point equals an integer).
2. Each I and Q waveform must have an even number of points.
3. Each I and Q waveform should be the same length. (Different length I and Q waveforms are allowed. The shorter waveform will give a 0V output from its end up to the length of the longer waveform.)
4. When overwriting a waveform in memory, you must rewrite both the I and Q waveforms.

Understanding Arbitrary Waveform Generator Triggers

The Arbitrary Waveform Generator includes several different triggering options. For information on setting up triggering schemes, see [“Using Arbitrary Waveform Generator Triggers”](#) on page 2-81.

NOTE Arbitrary waveform generator triggers, their associated softkeys and SCPI functionality became available in Option UN5/UND signal generators with serial number prefix US3844 or GB3845. Arbitrary waveform generator triggers are *not* available in Option UN5/UND signal generators with an earlier serial number prefix, unless upgraded.

To upgrade your Option UN5/UND signal generator to include arbitrary waveform generator triggering, contact your nearest Agilent Technologies Sales and Service office.

Trigger Types

There are four different trigger types available with Option UND: continuous, single, gated and segment advance. These trigger types can be accessed by pressing the appropriate softkey or sending the appropriate SCPI command via GPIB.

Continuous Triggering

This is the default trigger setting for the signal generator. When continuous triggering is selected, once the waveform has been generated and activated, it will repeat continuously until the mode is turned off.

Single Triggering

When single triggering is selected, once the waveform has been generated and activated, it will play once and then wait for another signal from the selected trigger source before playing again.

Gated Triggering

When gated triggering is selected, the waveform is set to output when a TTL high or low is present at the PATTERN TRIG IN connector on the signal generator's rear panel. Gated triggering includes one additional function: gate active low/high.

- Gate Active

Once the trigger has been set to gated, use gate active to toggle the polarity of the “through” or active state of a gated trigger signal. Gate active low will output the signal while the gate is in a TTL low state at the PATTERN TRIG IN connector. Gate active high has the opposite effect, outputting the signal while the signal level at the PATTERN TRIG IN connector is in a TTL high state.

Segment Advance Triggering

Segment advance is used while operating with a sequence of waveform segments. In segment advance mode, a given sequence is played continuously. When a trigger is received, the next segment in the sequence is played continuously.

Trigger Sources

There are three different trigger sources available with Option UND: the front-panel Trigger key, the GPIB interface, and external triggering.

The Trigger Key

With the trigger source set to trigger key, the waveform will trigger when the front-panel Trigger hardkey is pressed.

The GPIB Interface Bus

With the trigger source set to bus, the waveform will trigger when the signal generator receives the appropriate remote command (for example, *TRG in HP BASIC) over the GPIB interface bus.

External Triggering

With the trigger source set to external, the waveform will trigger when the signal generator receives a TTL signal at the PATTERN TRIG IN rear-panel connector. External triggering includes several additional functions: external polarity (positive or negative), external delay, and external delay time.

- External Polarity

The polarity of the external triggering signal can be set to either a positive change or a negative change in signal level.

- External Delay

A delay in the time an external trigger stimulus is received at the PATTERN TRIG IN connector to the time at which the waveform playback is started.

- External Delay Time

The amount of delay in the time an external trigger stimulus is received at the PATTERN TRIG IN connector and the time the waveform is actually output, variable from 2.0 microseconds to 3600 seconds.

Retrigger Mode

Using Retrigger Mode (**Retrigger Mode Off On** set to **On**), if a trigger occurs while a waveform is playing, the waveform will retrigger when it reaches the end. When using Retrigger Mode, triggers do not accumulate; if multiple triggers are sent to the signal generator as a waveform is playing only one trigger is kept until the end of the current waveform playback. With Retrigger Mode set to off, if a trigger occurs while a waveform is playing, it is ignored.

Understanding Baseband Clipping

In a CDMA waveform, high power peaks can cause intermodulation distortion, which generates spectral regrowth (a condition that interferes with signals in adjacent frequency bands). The clipping function allows you to reduce high power peaks.

How Power Peaks Develop

To understand how clipping reduces high power peaks in a CDMA signal, it is important to know how the peaks develop as the signal is constructed.

A CDMA waveform is composed of an I waveform and a Q waveform. Often, these waveforms are the summation of multiple channels (refer to [Figure 4-2](#)). Whenever most or all of the individual channel waveforms simultaneously contain a bit in the same state (high or low), an unusually high power peak (negative or positive) occurs in the summed waveform. This does *not* happen frequently because the high and low states of the bits on these channel waveforms are random, which causes a cancelling effect.

Figure 4-2 Multiple Channel Summing

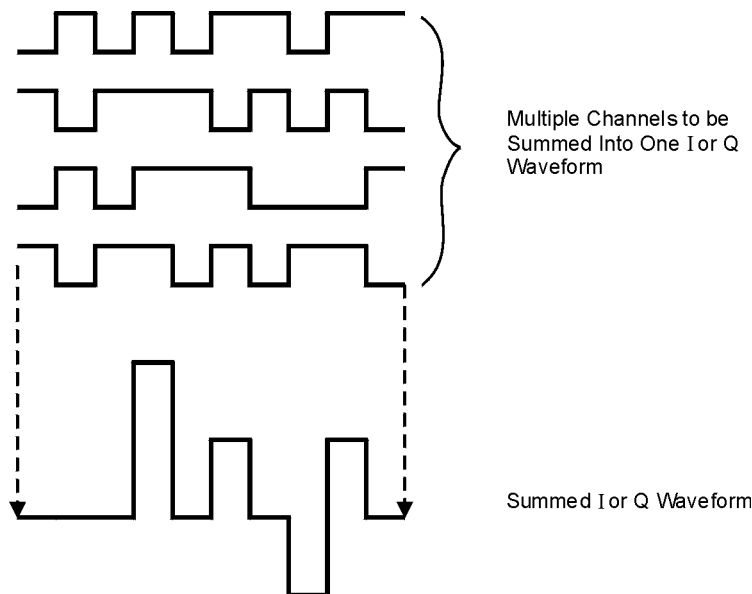

pk722b

The I and Q waveforms combine in the I/Q modulator to create an RF waveform. The magnitude of the RF envelope is determined by the equation $\sqrt{I^2+Q^2}$, where the squaring of I and Q always results in a positive value. Notice how simultaneous positive and negative peaks in the I and Q waveforms do not cancel each other, but combine to create an even greater peak (refer to [Figure 4-3](#)).

Figure 4-3 Combining the I and Q Waveforms

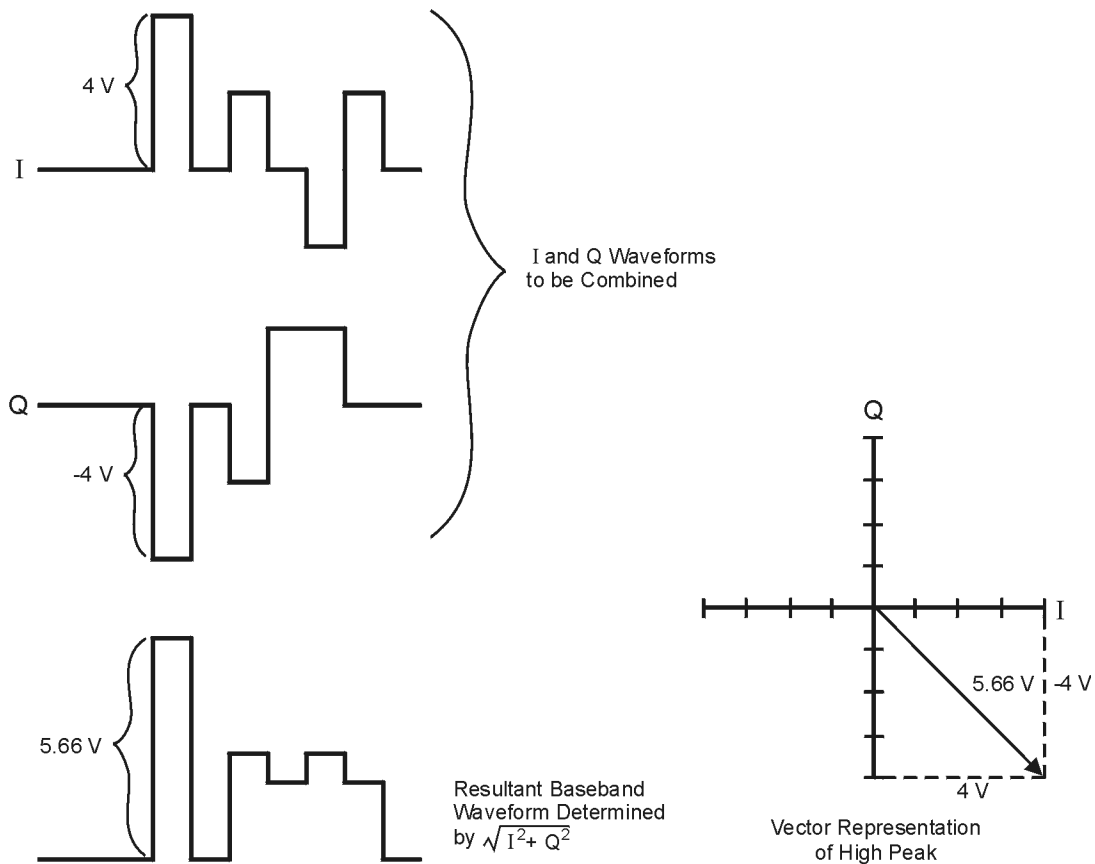

Pk750b

How Peaks Cause Spectral Regrowth

Because of the relative infrequency of high power peaks, a waveform will have a high peak-to-average power ratio (refer to [Figure 4-4](#)). Because a transmitter's power amplifier gain is set to provide a specific average power, high peaks can cause the power amplifier to move toward saturation. This causes intermodulation distortion, which generates spectral regrowth.

Figure 4-4 Peak-to-Average Power in the CDMA Waveform

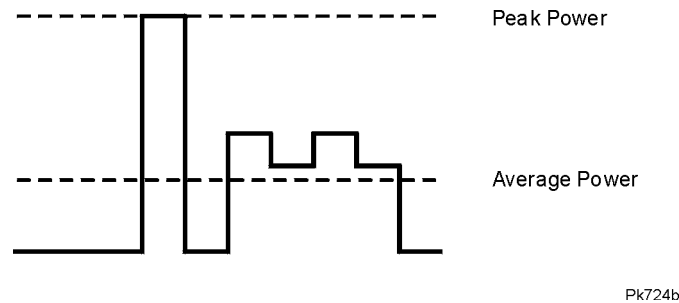

Spectral regrowth is a range of frequencies that develops on each side of the carrier (similar to sidebands) and extends into the adjacent frequency bands (refer to [Figure 4-5](#)). Consequently, spectral regrowth interferes with communication in the adjacent bands. Clipping can provide a solution to this problem.

Figure 4-5 Spectral Regrowth Interfering with Adjacent Band

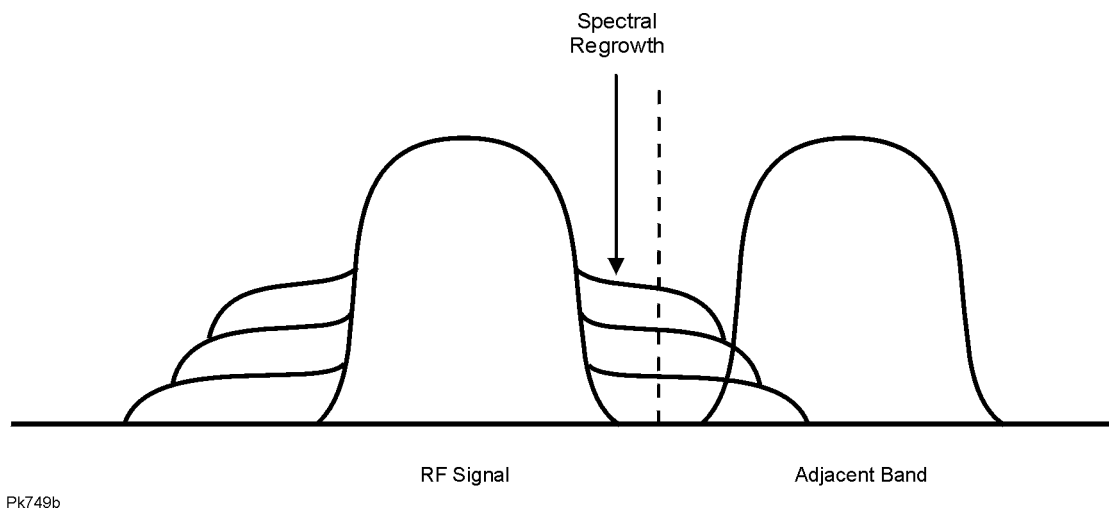

How Clipping Reduces Peak-to-Average Power

You can reduce peak-to-average power, and consequently spectral regrowth, by clipping the waveform to a selected percentage of its peak power. The ESG signal generator provides two different methods of clipping: circular and rectangular.

During *circular* clipping, clipping is applied to the combined I and Q RF waveform ($|I + jQ|$). Notice in [Figure 4-6](#) that the clipping level is constant for all phases of the vector representation and appears as a circle. During *rectangular* clipping, clipping is applied to the I and Q waveforms separately ($|I|$, $|Q|$). Notice in [Figure 4-7](#) that the clipping level is different for I and Q; therefore, it appears as a rectangle in the vector representation. With either method, the objective is to clip the waveform to a level that effectively reduces spectral regrowth, but does *not* compromise the integrity of the signal. [Figure 4-8](#) uses two complementary cumulative distribution plots to show the reduction in peak-to-average power that occurs after applying circular clipping to an RF waveform.

The lower you set the clipping value, the lower the peak power that is passed (or the more the signal is clipped). Often, the peaks can be clipped successfully without substantially interfering with the rest of the waveform. Data that might be lost in the clipping process is salvaged because of the error correction inherent in the coded systems. If you clip too much of the waveform, however, lost data is irrecoverable. You may have to try several clipping settings to find a percentage that works well.

Figure 4-6 Circular Clipping

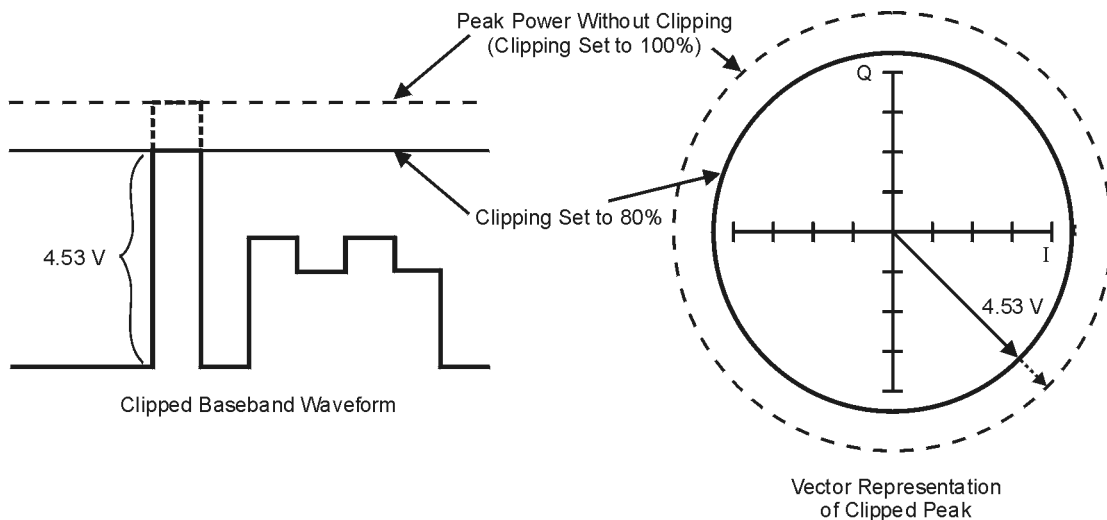

Pk748b

Figure 4-7 Rectangular Clipping

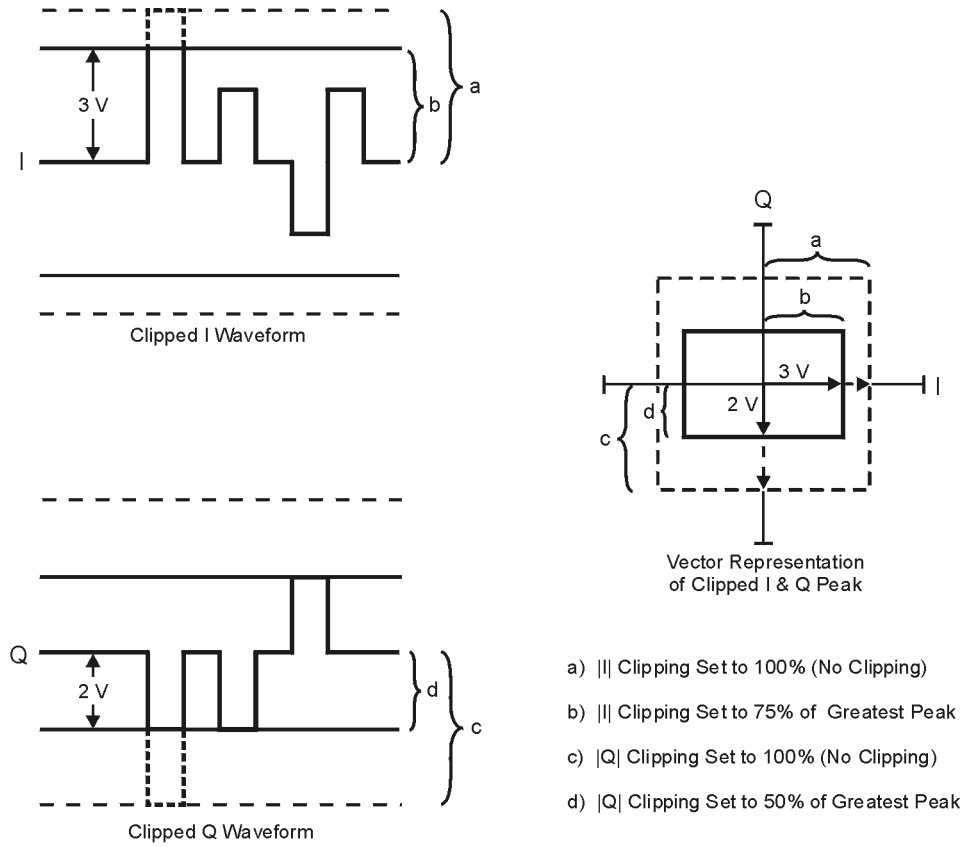

- a) |I| Clipping Set to 100% (No Clipping)
- b) |I| Clipping Set to 75% of Greatest Peak
- c) |Q| Clipping Set to 100% (No Clipping)
- d) |Q| Clipping Set to 50% of Greatest Peak

pk751b

Figure 4-8 Reduction of Peak-to-Average Power

Complementary Cumulative Distribution

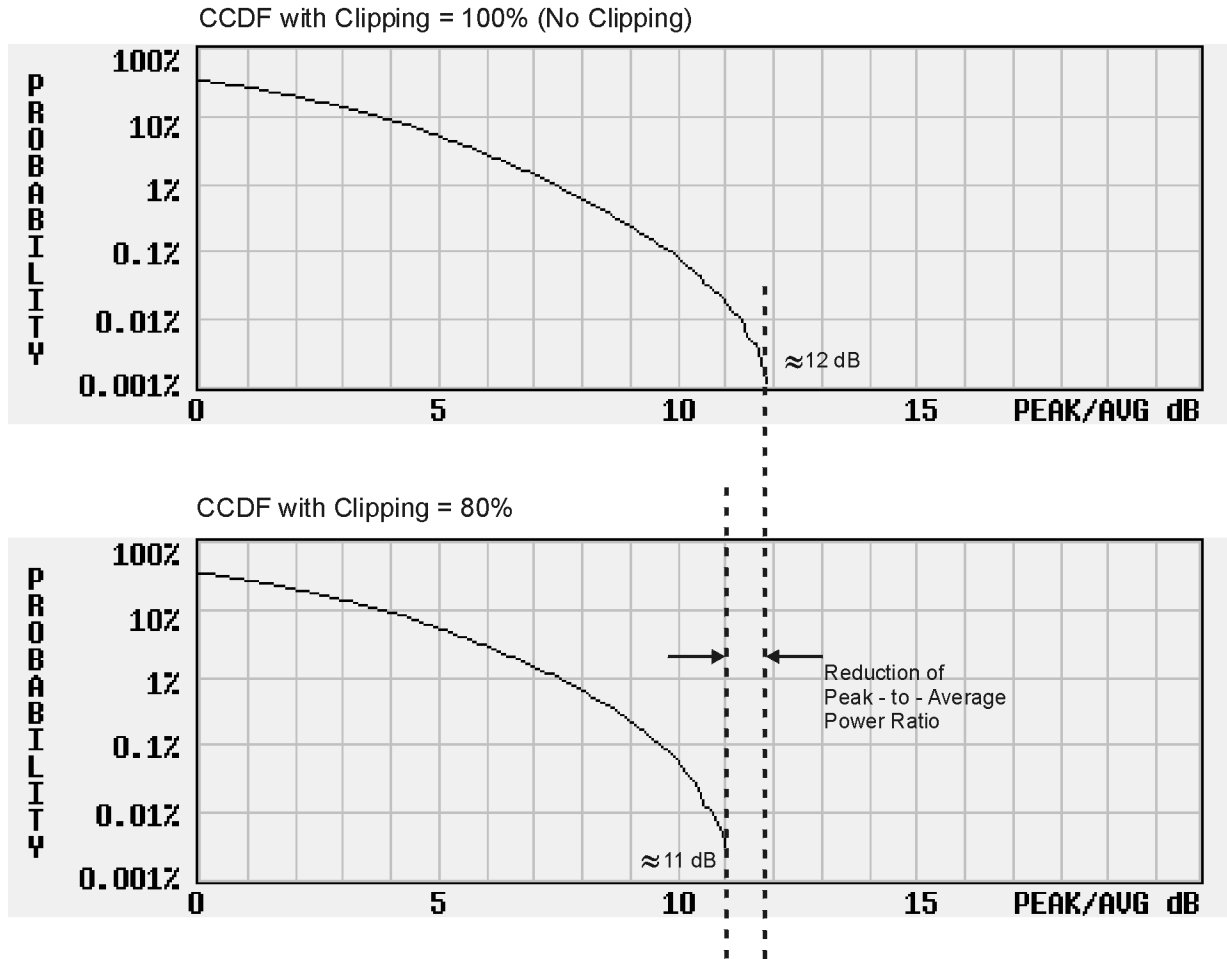

Pk734b

FIR Filtering Options (Option UN5 Only)

The ESG signal generator allows you to choose whether clipping occurs prior to, or after, FIR filtering. Because clipped waveforms have abrupt discontinuities which can generate noise, you can select *pre-FIR* filter clipping. The FIR filter smooths any discontinuities in the clipped waveform and prevents noise. If desired, however, you can also select *post-FIR* filter clipping.

5 Remote Programming

This chapter provides information about the CDMA and Dual ARB subsystem SCPI commands. The descriptions include syntax requirements, ranges, restrictions, query responses, and status after a *RST.

Bluetooth SCPI Command Reference

The Bluetooth SCPI commands are used to set the controls and the parameters associated with the Bluetooth communications standard via a remote controller.

Setting the Active Member Address

```
[ :SOURce]:RADio:BLUETooth:ARB:AMAddr <val>  
[ :SOURce]:RADio:BLUETooth:ARB:AMAddr?
```

The active member address (AM_ADDR) is used to distinguish between the active members on the piconet. In a piconet, one or more slaves are connected to a single master. A temporary 3-bit address is assigned to identify each active slave.

<val> address value (0 through 7)

*RST value: 1

Setting the Device Address

```
[ :SOURce]:RADio:BLUETooth:ARB:BDAddr <val>  
[ :SOURce]:RADio:BLUETooth:ARB:BDAddr?
```

Each Bluetooth transceiver is allocated a unique 48-bit Bluetooth device address (BD_ADDR). This address is derived from the IEEE802 standard.

*RST value: 000000 00 0008 (hexadecimal)

Burst Off On

```
[ :SOURce]:RADio:BLUETooth:ARB:BURSt[:STATe] ON|OFF|1|0  
[ :SOURce]:RADio:BLUETooth:ARB:BURSt[:STATe]?
```

This command sets the operating state for the burst function. The Bluetooth signal is a sequence of time-division duplex (TDD) bursts. When the burst is on, the signal is TDD. When the burst is off, there is a continuous signal.

*RST value: On

Setting Clock/Gate Delay

```
[ :SOURce]:RADio:BLUETooth:ARB:CGDelay <0 - 24999.9>  
[ :SOURce]:RADio:BLUETooth:ARB:CGDelay?
```

This command sets the number of symbols to shift the clock and gate signals relative to the ARB waveform generator. Refer to “[Clock/Gate Delay](#)” on page 3-20 for more information.

NOTE This option is available only when the payload data is continuous PN9 and is intended to be used during bit error rate (BER) testing.

*RST value: 0 Hz

Selecting the Payload Data

```
[ :SOURce]:RADio:BLUEtooth:ARB:DATA PN9|TPN9|CPN9|  
<#b00000000 - #b11111111>  
[ :SOURce]:RADio:BLUEtooth:ARB:DATA?
```

This command selects the payload data. Payload data is the user voice or data information that is carried in a packet. The choices are continuous PN9, truncated PN9, or an 8-bit pattern. A change in the payload data type resets the eight bit pattern to the default value (0000 0000).

NOTE PN9 is accepted as a command parameter to maintain backward compatibility with previous versions of firmware, however, a query will return TPN9 instead of PN9.

*RST value: TPN9

Setting Frequency Drift

```
[ :SOURce]:RADio:BLUEtooth:ARB:FDRift <-100.0 kHz - 100.0 kHz>  
[ :SOURce]:RADio:BLUEtooth:ARB:FDRift?
```

This command sets the desired frequency drift.

NOTE This command applies to a previous version of firmware and remains for backward compatibility only. If you are using the latest firmware see [“Setting Drift Deviation”](#) on page 5-4.

*RST value: 0.0 Hz

Setting Frequency Offset

```
[ :SOURce]:RADio:BLUEtooth:ARB:FOFFset <-100.0 kHz - 100.0 kHz>  
[ :SOURce]:RADio:BLUEtooth:ARB:FOFFset?
```

This command sets the desired frequency offset.

NOTE This command applies to a previous version of firmware and remains for backward compatibility only. If you are using the latest firmware see [“Setting the Frequency Offset”](#) on page 5-5.

*RST value: 0.0 Hz

Setting the Modulation Index

```
[ :SOURce]:RADio:BLUETooth:ARB:MINdex <0.25000 - 0.40000>  
[ :SOURce]:RADio:BLUETooth:ARB:MINdex?
```

This command sets the modulation index for the Bluetooth signal.

NOTE This command applies to a previous version of firmware and remains for backward compatibility only. If you are using the latest firmware see [“Setting the Modulation Index”](#) on page 5-5.

*RST value: 0.315

Impairments

Selecting AWGN

```
[ :SOURce]:RADio:BLUETooth:ARB:IMPairments:AWGN ON|OFF|1|0  
[ :SOURce]:RADio:BLUETooth:ARB:IMPairments:AWGN?
```

This command selects AWGN as a Bluetooth impairment. The choices are ON (1) or OFF (0).

*RST value: OFF

Setting the Carrier to Noise Ratio for AWGN

```
[ :SOURce]:RADio:BLUETooth:ARB:IMPairments:AWGN:CNR[1MHz] <10 dB - 40 dB>  
[ :SOURce]:RADio:BLUETooth:ARB:IMPairments:AWGN:CNR?
```

This command sets the carrier to noise ratio, for 1 MHz bandwidth, for the Bluetooth AWGN impairment.

*RST value: 21 dB

Setting Drift Deviation

```
[ :SOURce]:RADio:BLUETooth:ARB:IMPairments:DDEViation <-100.0 kHz - 100.0 kHz>  
[ :SOURce]:RADio:BLUETooth:ARB:IMPairments:DDEViation?
```

This command sets the deviation of the frequency drift for linear carrier frequency ramping or sinusoidal frequency modulation of the carrier frequency.

*RST value: 0.0 Hz

Selecting Frequency Drift Type

```
[ :SOURce]:RADio:BLUEtooth:ARB:IMPairments:FDType LINear|SINE
[:SOURce]:RADio:BLUEtooth:ARB:IMPairments:FDType?
```

This command selects an optional frequency drift impairment as part of a Bluetooth setup. The choices are linear or sine. Refer to “[Freq Drift Type Linear Sine](#)” on page 3-35 for more information.

*RST value: Sine

Setting the Frequency Offset

```
[ :SOURce]:RADio:BLUEtooth:ARB:IMPairments:FOFFset <-100.0 kHz - 100.0 kHz>
[:SOURce]:RADio:BLUEtooth:ARB:IMPairments:FOFFset?
```

This command sets a frequency offset impairment as part of a Bluetooth setup.

*RST value: 0.0 Hz

Selecting the Impairments Function

```
[ :SOURce]:RADio:BLUEtooth:ARB:IMPairments ON|OFF|1|0
[:SOURce]:RADio:BLUEtooth:ARB:IMPairments?
```

This command sets the operating state of the impairments. The choices are ON (1) or OFF (0). The impairment options are applied only when impairments is set to ON.

*RST value: OFF

Setting the Modulation Index

```
[ :SOURce]:RADio:BLUEtooth:ARB:IMPairments:MINdex <0.25000 - 0.40000>
[:SOURce]:RADio:BLUEtooth:ARB:IMPairments:MINdex?
```

This command sets the modulation index for a Bluetooth impairment.

*RST value: 0.315

Setting the Noise Seed for AWGN

```
[ :SOURce]:RADio:BLUEtooth:ARB:IMPairments:AWGN:NSEed <1 - 65535>
[:SOURce]:RADio:BLUEtooth:ARB:IMPairments:AWGN:NSEed?
```

This command sets the noise seed for the Bluetooth AWGN impairment.

*RST value: 1

Setting the Symbol Timing Error

```
[ :SOURce]:RADio:BLUETooth:ARB:IMPairments:STERror <-50 ppm - 50 ppm>  
[ :SOURce]:RADio:BLUETooth:ARB:IMPairments:STERror?
```

This command sets the value of the symbol timing error for a Bluetooth impairment. The sample rate of the arbitrary waveform generator shifts to generate the symbol timing error. A 20 ppm timing error corresponds to a 20 Hz shift in the symbol rate.

*RST value: 0 ppm

Selecting a Packet

```
[ :SOURce]:RADio:BLUETooth:ARB:PACKet DH1  
[ :SOURce]:RADio:BLUETooth:ARB:PACKet?
```

This command selects a DH1 packet, which is a single bundle of information transmitted within a piconet. A DH1 packet covers a single timeslot.

*RST value: DH1

Setting the Burst Power Ramp

```
[ :SOURce]:RADio:BLUETooth:ARB:RSYMBOLs <1 - 10>  
[ :SOURce]:RADio:BLUETooth:ARB:RSYMBOLs?
```

This command controls how long it takes the RF burst to ramp up at the beginning of the packet transmission and down at the end of the packet. The ramp time is measured in symbols (1 symbol interval = 1 μ s).

*RST value: 6

Turning On Bluetooth

```
[ :SOURce]:RADio:BLUETooth:ARB[:STATe] ON|OFF|1|0  
[ :SOURce]:RADio:BLUETooth:ARB[:STATe]?
```

This command turns the operating state for Bluetooth waveform generator on or off.

*RST value: OFF

CDMA Subsystem SCPI Command Reference (Options UND and UN5 Required)

The CDMA subsystem SCPI commands are used to set the controls and the parameters associated with IS-95A communications standard via a remote controller. These commands are only for signal generators with both Options UND and UN5.

ARB Reference Internal External

```
[ :SOURce ] :RADio :ARB :CLOCK :REFerence [ :SOURce ] INTernal | EXTernal  
[ :SOURce ] :RADio :ARB :CLOCK :REFerence [ :SOURce ] ?
```

This command selects either an internal or external reference for the waveform clock. If external is selected, the external frequency *must* be entered (see the Reference Frequency command) and the signal must be applied to the BASEBAND GEN REF IN connector.

*RST value: Internal

CDMA State

```
[ :SOURce ] :RADio :CDMA :ARB [ :STATe ] ON | OFF | 1 | 0  
[ :SOURce ] :RADio :CDMA :ARB [ :STATe ] ?
```

This command enables or disables the CDMA capability. The choices are ON (1) or OFF (0). Executing the command [:SOURce] :RADio :CDMA :ARB [:STATe] ON sets up the internal hardware to generate the currently selected CDMA signal selection. The CDMA and I/Q annunciators are turned on in the display. Although the digital modulation is enabled with this softkey, the enabled modulation is not present on RF carrier until you have activated the modulation by executing the command :OUTPut :MODulation [:STATe] ON.

Executing the command [:SOURce] :RADio :CDMA :ARB [:STATe] ON activates the I/Q state and sets the I/Q source to internal. You can override these selections in the I/Q menu.

*RST value: Off

Channel Setup

```
[ :SOURce]:RADio:CDMA:ARB:SETup:CHANnel  
IS97|EQUal|SCALE|NONE, <chan_type>, <walsh_code>, <power_value>, <pnofs_value>, R  
ANDom|<data_value>  
{, <chan_type>, <walsh_code>, <power_value>, <pnofs_value>, RANDom|<data_value>}  
[ :SOURce]:RADio:CDMA:ARB:SETup:CHANnel?
```

This command defines the channel parameters of the CDMA signal. These parameters include:

- IS97|EQUal|SCALE|NONE - code domain power settings
 - IS97 - sets the channel power levels to IS-97-defined power levels.
 - EQUal - sets the channel power levels so that all channels are of equal power and the total power equals 0 dBm.
 - SCALE - scales all of the current channel powers so that the total power equals 0 dB while keeping the previous power ratios between the individual channels.
 - NONE - default power settings
- <chan_type> - channel type
 - PILot - a pilot channel
 - SYNC - a sync channel
 - PAGing - a paging channel
 - TRAFfic - a traffic channel
- <walsh_code> - the walsh code assigned to the channel (0, 63)
- <power_value> - the channel power in dB (-40 to 0 dB)
- <pnofs_value> - the PN offset value (0, 511)
- RANDom|<data_value> - the transmitted data
 - RANDom - random data
 - <data_value> - user-defined data (0 to 255)

*RST value: Off

Channel Setup Program Example:

```
5    INTEGER Pn
10   ASSIGN @Esg TO 719
15   !    Start the Channel Process
20   !    With the Is97 selection the powers of the channels will
25   !    automatically be adjusted to IS97 Levels once the channel
30   !    setup is complete
35   OUTPUT @Esg USING "K,#";"SOURCE:RADIO:CDMA:ARB:SETUP:CHAN IS97,"
40   !
45   !    Set the PN Offset to 12
50   Pn=12
55   !
60   !    Pilot
65   OUTPUT @Esg USING "K,#";"PILOT,0,-3,"&VAL$(Pn)&",000000,"
70   !
75   !    PAGING ON CHANNEL 1
80   OUTPUT @Esg USING "K,#";"PAGING,1,-3,"&VAL$(Pn)&",RANDOM,"
85   !
90   !    SYNC ON CHANNEL 32
95   OUTPUT @Esg USING "K,#";"SYNC,32,-3,"&VAL$(Pn)&",RANDOM,"
100  !
105  !    Set up Traffic Channels on walsh 8 to 40
110  FOR N=8 TO 40
115    OUTPUT @Esg USING "K,#";"TRAFFIC,"&VAL$(N)&",-5,"&VAL$(Pn)&"RANDOM,"
120  NEXT N
125  !
130  !    TERMINATE CHANNEL STRUCTURE
135  OUTPUT 719;" "
140  !
145  END
```

Chip Rate

```
[SOURCE]:RADIO:CDMA:ARB:CRATE <value>
[SOURCE]:RADIO:CDMA:ARB:CRATE?
```

This command sets the chip rate. Choices for the variable <value> range from 10 cps to 40 Mcps. The maximum chip rate is 20 Mcps using a 2 times oversample rate.

*RST value: 1.2288000 Mcps

Clipping Level, |I+jQ|

```
[ :SOURce]:RADio:CDMA:ARB:CLIPping[:IJQ] <10-100%>  
[:SOURce]:RADio:CDMA:ARB:CLIPping[:IJQ]?
```

Execute this command to clip (limit) the modulation level of the combined I and Q waveform to a percentage of full scale. A level of 100.0% equates to no clipping.

*RST Value: 100.0%

Clipping Level, |I|

```
[ :SOURce]:RADio:CDMA:ARB:CLIPping:I <10-100%>  
[:SOURce]:RADio:CDMA:ARB:CLIPping:I?
```

Execute this command to clip (limit) the modulation level of the waveform's I component to a percentage of full scale. A level of 100.0% equates to no clipping.

*RST Value: 100.0%

Clipping Level, |Q|

```
[ :SOURce]:RADio:CDMA:ARB:CLIPping:Q <10-100%>  
[:SOURce]:RADio:CDMA:ARB:CLIPping:Q?
```

Execute this command to clip (limit) the modulation level of the waveform's Q component to a percentage of full scale. A level of 100.0% equates to no clipping.

*RST Value: 100.0%

Clipping, Pre/Post FIR Filter

```
[ :SOURce]:RADio:CDMA:ARB:CLIPping:POSition PRE|POST  
[:SOURce]:RADio:CDMA:ARB:CLIPping:POSition?
```

Execute this command to select whether you want the waveform to be clipped before (PRE) or after (POST) FIR filtering.

*RST Value: PRE

Clipping, Type

```
[ :SOURce]:RADio:CDMA:ARB:CLIPping:TYPE IJQ|IORQ  
[:SOURce]:RADio:CDMA:ARB:CLIPping:TYPE?
```

Execute this command to select either IJQ or IORQ as the clipping type. If you select IJQ, the combined I and Q waveform will be clipped (*circular* clipping). If you select IORQ, the I and Q components of the waveform are clipped independently (*rectangular* clipping). In this case, you can clip I and Q to different levels.

*RST Value: IJQ

Custom CDMA State, Store

```
[ :SOURce]:RADio:CDMA:ARB:SETup:STORE "<file name>"
```

This command stores the current custom CDMA state into a designated file name. Afterward, you can recall this custom state from the signal generator's memory by executing the command `[:SOURce]:RADio:CDMA:ARB:SETup: "<file name>"` with the appropriate file name in place of the variable.

Along with the contents of the CDMA channel table editor (channel types, Walsh code, power levels, PN offset, and data), this softkey stores the following instrument state information to the memory catalog:

- FIR filter
- FIR filter file name
- FIR filter alpha
- FIR filter BbT
- FIR filter channel (EVM or ACP)
- chip rate
- waveform length
- oversample ratio
- ARB reconstruction filter
- ARB reference clock source (internal or external)
- ARB reference clock frequency

Custom Multicarrier, Store

```
[ :SOURce]:RADio:CDMA:ARB:SETup:MCARrier:STORE "<file name>"
```

This command allows you to store the current changes to the default multicarrier setup into the file you enter. Afterward, you can recall these custom multicarrier settings from the signal generator's memory by executing the following command:

```
[ :SOURce]:RADio:CDMA:ARB:SETup:MCARrier "<file name>"
```

This command stores the following instrument state information to the memory catalog:

- type of carriers
- frequency offset for each carrier
- power level for each carrier
- the number of different carriers

External Delay State

```
[ :SOURCE ]:RADio:CDMA:ARB:TRIGger[ :SOURCE ]:EXTernal:DElay:STATE  
ON|OFF|1|0[ :SOURCE ]:RADio:CDMA:ARB:TRIGger  
[ :SOURCE ]:EXTernal:DElay:STATE?
```

This command sets the operating state for the external trigger delay. The choices are On or Off.

*RST value: Off

External Delay Time

```
[ :SOURCE ]:RADio:CDMA:ARB:TRIGger[ :SOURCE ]:EXTernal:DElay <value>  
[ :SOURCE ]:RADio:CDMA:ARB:TRIGger[ :SOURCE ]:EXTernal:DElay?
```

This command sets the time for the external trigger delay. The range of values allowed for the variable <value> is 2.000 microseconds through 3600 seconds.

*RST value: 2.000 msec

External Polarity

```
[ :SOURCE ]:RADio:CDMA:ARB:TRIGger[ :SOURCE ]:EXTernal:SLOPe POSitive|NEGative  
[ :SOURCE ]:RADio:CDMA:ARB:TRIGger[ :SOURCE ]:EXTernal:DElay:STATE?
```

This command sets the polarity of the external trigger. The choices are Positive or Negative.

*RST value: Negative

Filter Alpha, Nyquist, or Root Nyquist

```
[ :SOURCE ]:RADio:CDMA:ARB:FILTer:ALPHa <value>  
[ :SOURCE ]:RADio:CDMA:ARB:FILTer:ALPHa?
```

This command changes the Nyquist or root Nyquist filter's alpha value. The acceptable range for the variable <value> is 0.000 through 1.000.

This command is effective only *after* choosing a Root Nyquist or Nyquist filter. It does not have an effect on other types of filters.

*RST value: 0.500

Filter BbT, Gaussian

```
[ :SOURce]:RADio:CDMA:ARB:FILTer:BBT <value>  
[ :SOURce]:RADio:CDMA:ARB:FILTer:BBT?
```

This command changes the bandwidth-multiplied-by-bit-time (BbT) filter parameter. The acceptable range for the variable <value> is 0.000 through 1.000.

This command is effective only *after* choosing a Gaussian filter. It does not have an effect on other types of filters.

*RST value: 0.500

Filter Selection

```
[ :SOURce]:RADio:CDMA:ARB:FILTer RNYQuist|NYQuist|GAUSSian|RECTangle|IS95|  
IS95_EQ|IS95_MOD|IS95_MOD_EQ|WCDMa|AC4Fm|IS2000SR3DS| "<file name>"  
[ :SOURce]:RADio:CDMA:ARB:FILTer?
```

This command selects the pre-modulation filter type. The choices are:

- RNYQuist - Root Nyquist filter
- NYQuist - Nyquist filter
- GAUSSian - Gaussian filter
- RECTangle - Rectangle filter
- IS95 - Standard IS-95 filter
- IS95_MOD - a modified version of an IS-95 filter which meets the IS-95 error function for improved adjacent channel performance
- IS95_EQ - a modified version of an IS-95 filter with an equalizer which provides base station phase equalization for the transmit signal path
- IS95_MOD_EQ - a modified version of an IS-95 filter which meets the IS-95 error function for improved adjacent channel performance with an equalizer which provides base station phase equalization for the transmit signal path
- WCDMa - a Nyquist filter with an alpha of 0.22 optimized for adjacent channel performance
- AC4Fm - an APCO 25-specified C4FM filter
- IS2000SR3DS - a modified IS-2000 spreading rate 3, direct spread filter
- "<file name>" - any filter file that you have either created externally and downloaded into memory, or that you have created internally in the Define User FIR menu and then subsequently stored

*RST value: IS-95 (Modified with Equalization)

Filter Optimization

```
[ :SOURCE]:RADio:CDMA:ARB:FILTer:CHANnel EVM|ACP  
[ :SOURCE]:RADio:CDMA:ARB:FILTer:CHANnel?
```

This command is used to optimize the filter for minimized error vector magnitude (select EVM) or to minimized adjacent channel power (select ACP). The EVM selection provides the most ideal passband. The ACP selection improves stopband rejection. This feature only applies to Root Nyquist, Nyquist, and Gaussian filters. The softkey is grayed out when any other filter is selected.

*RST value: EVM

Gate Active

```
[ :SOURCE]:RADio:CDMA:ARB:TRIGger:TYPE:GATE:ACTive LOW|HIGH  
[ :SOURCE]:RADio:CDMA:ARB:TRIGger:TYPE:GATE:ACTive?
```

This command toggles the polarity of the “through” or active state of a gated trigger signal. The choices are low or high. Gate active low will output the signal while the gate is low at the PATTERN TRIG IN connector. Gate active high has the opposite effect, outputting the signal while the signal level at the PATTERN TRIG IN connector is in a high state.

*RST value: N/A

Multicarrier Define

```
[ :SOURCE]:RADio:CDMA:ARB:SETup:MCARrier:TABLE {FWD9|FWD32|FWD64|PILot|  
CUSTom,"<file name>"|"",<freq_offset>,<power>}  
[ :SOURCE]:RADio:CDMA:ARB:SETup:MCARrier:TABLE?
```

This command defines the multicarrier CDMA waveform. The choices are:

- FWD9 - a 9 channel forward carrier
- FWD32 - a 32 channel forward carrier
- FWD64 - a 64 channel forward carrier
- Pilot -pilot channel
- CUSTom - a custom multicarrier CDMA waveform stored in the signal generator’s memory, or created by modifying the 3-carrier or 4-carrier template.
- "<file name>" - a custom multicarrier CDMA waveform stored in the signal generator’s memory. This value is entered only for a custom carrier.
- "" - A null string, entered for any non-custom carrier.
- <freq_offset> - the frequency offset in hertz. Do not enter units. For example, enter 1.25 MHz as 1250000.
- <power> - the power level in dB. Do not enter units. For example, enter –4.28 dB as –4.28.

Multicarrier Setup Select

```
[ :SOURce]:RADio:CDMA:ARB:SETup:MCARrier CAR3|CAR4| "<file name>"  
[ :SOURce]:RADio:CDMA:ARB:SETup:MCARrier?
```

This command defines the type of multicarrier CDMA setup required for your application. The choices include:

- CAR3 - three 9 channel forward carriers with a power level of 0.00 dB, the first with a -1.25 MHz frequency offset, the second with no frequency offset, and the third with +1.25 MHz frequency offset.
- CAR4 - four 9 channel forward carriers with a power level of 0.00 dB, the first with a -1.875 MHz frequency offset, the second with a -625 kHz frequency offset, the third with +625 kHz frequency offset, and the fourth with a +1.875 MHz frequency offset.
- "<file name>" - a user-defined multicarrier CDMA state file previously stored in the signal generator's non-volatile memory.

*RST value: 3 Carriers

Oversample Ratio

```
[ :SOURce]:RADio:CDMA:ARB:OSAMple <value>  
[ :SOURce]:RADio:CDMA:ARB:OSAMple?
```

This command sets the oversampling ratio (number of filter taps per symbol) for CDMA modulation. The acceptable range for the variable <value> is 2 through 8. Using larger oversample ratios results in more completely filtered images but also uses up more waveform memory.

The upper limit of the oversample ratio is adjusted based on the waveform length and chip rate. The maximum oversample ratio is the smaller of the following three values:

- 40 Mcps/Chip Rate
- 8
- 32/Waveform Length (Note the Waveform Length is the number of CDMA short codes)

*RST value: 0.500

Reconstruction Filter

```
[ :SOURce]:RADio:ARB:RFILter <value>|THROUGH  
[ :SOURce]:RADio:ARB:RFILter?
```

This command is used to modify the reconstruction filter. You may choose a filter with a cutoff frequency of 250.0 kHz, 2.500 MHz, 8.000 MHz or no filter (THROUGH). Acceptable values for the variable <value> are 250.0 kHz, 2.500 MHz, or 8.000 MHz.

*RST value: 2.500 MHz

Reference Frequency

```
[ :SOURce]:RADio:ARB:CLOCK:REfERENCE:EXtERnal:FREQuency <value>  
[ :SOURce]:RADio:ARB:CLOCK:REfERENCE:EXtERnal:FREQuency?
```

This command sets the reference frequency of the external clock. It is only effective when you are using an external ARB reference applied to the BASEBAND GEN REF IN connector. The acceptable range for the variable <value> is 250.0000 kHz to 20.0000000 MHz.

*RST value: 10.0000000 MHz

Retrigger Mode State

```
[ :SOURce]:RADio:ARB:RETRigger ON|OFF|1|0  
[ :SOURce]:RADio:ARB:RETRigger?
```

This command sets the operating state of the retrigger mode. The choices are On or Off.

*RST value: On

Setup Select

```
[ :SOURce]:RADio:CDMA:ARB:SETup FWD9|FWD32|FWD64|PILOt|REVerse|MCARrier|  
"<file name>"  
[ :SOURce]:RADio:CDMA:ARB:SETup?
```

This command defines the type of CDMA channelization required for your application. The choices include:

- **PILOt** - a single pilot channel
- **FWD9** - a CDMA setup consisting of 9 channels (including pilot, paging, sync, and 6 traffic channels) at IS-97-defined power levels.
- **FWD32** - a CDMA setup consisting of 32 channels (including pilot, paging, sync, and 29 traffic channels) at IS-97-defined power levels.
- **FWD64** - a CDMA setup consisting of 64 channels (including pilot, 7 paging, sync, and 55 traffic channels) at IS-97-defined power levels.
- **REVerse** - a single traffic channel.
- **MCARrier** - the default multicarrier mode, a 3 carrier setup. This selection activates Multicarrier mode and deactivates any other mode that was previously on.
- "**<file name>**" - a user-defined CDMA state file previously stored in the signal generator's non-volatile memory.

*RST value: 9 Ch Fwd

Trigger Source

```
[ :SOURce ] :RADio :CDMA :ARB :TRIGger [ :SOURce ] KEY | EXT | BUS  
[ :SOURce ] :RADio :CDMA :ARB :TRIGger [ :SOURce ] ?
```

This command sets the trigger source. The choices include the front-panel Trigger key, a trigger command sent over the GPIB bus, or an external trigger applied to the PATTERN TRIG IN connector.

*RST value: Ex

Trigger Type

```
[ :SOURce ] :RADio :CDMA :ARB :TRIGger :TYPE CONTinuous | SINGLE | GATE | SADVance  
[ :SOURce ] :RADio :CDMA :ARB :TRIGger :TYPE ?
```

This command sets the trigger type. The choices are continuous, single, gated, and when a waveform sequence is active, segment advance.

*RST value: Continuous

User FIR Definition

```
MEMory :DATA :FIR "<file name>", osr, coefficient { , coefficient }  
MEMory :DATA :FIR ? "<file name>"
```

This command is used to define User FIR filters. A maximum filter length of 1024 taps is allowed with a maximum oversampling ratio of 32. An FIR filter selected for use in CDMA, however, cannot have more than 256 taps so the number of symbols and the oversample ratio should be selected accordingly. Examples of using the FIR table editor are provided in [Chapter 2, "Using Functions."](#)

Waveform Length

```
[ :SOURce ] :RADio :CDMA :ARB :WLENgth <value>  
[ :SOURce ] :RADio :CDMA :ARB :WLENgth ?
```

This command adjusts the waveform length (in short codes). The acceptable range for the variable <value> is 1 to 32 short codes. The upper limit is adjusted based on the oversample ratio to fit the signal within the available memory. The maximum waveform length is 32/oversample ratio.

*RST value: 1

Digital Modulation Subsystem SCPI Command Reference

The Digital Modulation subsystem SCPI commands are used to set the controls and parameters for generating predefined or custom digital modulation single carrier or multicarrier waveforms via a remote controller.

Define User FIR

```
:MEMory:DATA:FIR "<file name>", osr,coefficient{,coefficient}
```

This command creates a user FIR file that you can use with the signal generator.

Digital Modulation Setup

```
[ :SOURce]:RADio:DMODulation:ARB:SETup GSM|NADC|PDC|PHS|DECT|AC4Fm|ACQPsk|  
CDPD|PWT|EDGE|TETRA|MCARrier|"<file name>"  
[ :SOURce]:RADio:DMODulation:ARB:SETup?
```

This command selects the type of digital modulation format for your application. The choices include the following formats:

- GSM
- NADC
- PDC
- PHS
- DECT
- APCO 25 w/C4FM
- APCO 25 w/CQPSK
- CDPD
- PWT
- EDGE
- TETRA
- Multicarrier setup
- Custom user file

*RST value: NADC

Digital Modulation State

```
[ :SOURce]:RADio:DMODulation:ARB[:STATe] ON|OFF|1|0  
[ :SOURce]:RADio:DMODulation:ARB[:STATe]?
```

This command enables or disables the digital modulation capability. The choices are ON (1) or OFF (0). Executing the command `[:SOURce]:RADio:DMODulation:ARB[:STATe] ON` sets up the internal hardware to generate the currently selected digital modulation format signal selection. Although the digital modulation is enabled with this command, the enabled modulation is not present on the RF carrier until you have activated the modulation by executing the command `:OUTPut:MODulation[:STATe] ON`.

Executing the command `[:SOURce]:RADio:DMODulation:ARB[:STATe] ON` activates the I/Q state and sets the I/Q source to internal. You can override these selections in the I/Q menu.

*RST value: Off

External Delay State

```
[ :SOURce ]:RADio:DMODulation:ARB:TRIGger[ :SOURce ]:EXTernal:DELay:
STATe ON|OFF|1|0
[ :SOURce ]:RADio:DMODulation:ARB:TRIGger[ :SOURce ]:EXTernal:DELay:STATe?
```

This command sets the operating state for the external trigger delay. The choices are ON (1) or OFF (0).

*RST value: Off

External Delay Time

```
[ :SOURce ]:RADio:DMODulation:ARB:TRIGger[ :SOURce ]:EXTernal:DELay <value>
[ :SOURce ]:RADio:DMODulation:ARB:TRIGger[ :SOURce ]:EXTernal:DELay?
```

This command sets the time for the external trigger delay. The acceptable range for the variable `<value>` is 2.000 microseconds through 3600 seconds.

*RST value: 2.000 msec

External Polarity

```
[ :SOURce ]:RADio:DMODulation:ARB:TRIGger[ :SOURce ]:EXTernal:SLOPe POSitive|
NEGative
[ :SOURce ]:RADio:DMODulation:ARB:TRIGger[ :SOURce ]:EXTernal:SLOPe?
```

This command sets the polarity of the external trigger. The choices are POSitive or NEGative.

*RST value: Negative

Filter Alpha, Nyquist, or Root Nyquist

```
[ :SOURce ]:RADio:DMODulation:ARB:FILTer:ALPHa <value>
[ :SOURce ]:RADio:DMODulation:ARB:FILTer:ALPHa?
```

This command changes the Nyquist or root Nyquist filter's alpha value. The acceptable range for the variable `<value>` is 0.000 through 1.000.

This command is effective only *after* choosing a Root Nyquist or Nyquist filter. It does not have an effect on other types of filters.

*RST value: 0.500

Filter BbT, Gaussian

```
[ :SOURce]:RADio:DMODulation:ARB:FILTer:BBT <value>  
[ :SOURce]:RADio:DMODulation:ARB:FILTer:BBT?
```

This command changes the bandwidth-multiplied-by-bit-time (BbT) filter parameter. The acceptable range for the variable <value> is 0.000 through 1.000.

This command is effective only *after* choosing a Gaussian filter. It does not have an effect on other types of filters.

*RST value: 0.500

Filter Optimization

```
[ :SOURce]:RADio:CDMA:ARB:FILTer:CHANnel EVM|ACP  
[ :SOURce]:RADio:CDMA:ARB:FILTer:CHANnel?
```

This command is used to optimize the filter for minimized error vector magnitude (select EVM) or minimized adjacent channel power (select ACP). The EVM selection provides the most ideal passband. The ACP selection improves stopband rejection. This feature only applies to root Nyquist, Nyquist, and Gaussian filters. The softkey is grayed out when any other filter is selected.

*RST value: EVM

Filter Selection

```
[ :SOURce]:RADio:DMODulation:ARB:FILTer RNYQuist|NYQuist|GAUSSian|RECTangle|  
IS95|IS95_EQ|IS95_MOD|IS95_MOD_EQ|WCDMa|AC4Fm|IS2000SR3DS| "<file name>"  
[ :SOURce]:RADio:DMODulation:ARB:FILTer?
```

This command selects the pre-modulation filter type. The choices are:

RNYQuist	root Nyquist (root raised cosine) filter
NYQuist	Nyquist (raised cosine) filter
GAUSSian	Gaussian filter - adjusted using Bbt
RECTangle	rectangle filter - one symbol wide
IS95	standard cdmaOne IS-95 filter
IS95_EQ	modified IS-95 filter with an equalizer that provides base station phase equalization for the transmit signal path
IS95_MOD	modified IS-95 filter that meets the IS-95 error function for improved adjacent channel performance
IS95_MOD_EQ	modified IS-95 filter that meets the IS-95 error function for improved adjacent channel performance with an equalizer that provides base station phase equalization for the transmit signal path
WCDMa	a Nyquist filter with an alpha of 0.22 optimized for adjacent channel performance
AC4Fm	APCO 25 specified C4FM filter
IS2000SR3DS	modified IS-2000 spreading rate 3 direct spread filter
"<file name>"	a filter file created externally and downloaded into memory, or created internally in the Define User FIR menu, and then stored

*RST value: Root Nyquist

Filter defaults vary, depending on the digital modulation setup:

Digital Modulation Setup	Default Filter
NADC, PDC, PHS, PWT, TETRA:	Root Nyquist
GSM, DECT, CDPD:	Gaussian
EDGE:	EDGE
APCO 25 w/C4FM:	APCO 25 C4FM
APCO 25 w/CQPSK:	Nyquist

FSK Frequency Deviation

```
[ :SOURce]:RADio:DMODulation:ARB:MODulation:FSK[:DEViation] <val><unit>
[:SOURce]:RADio:DMODulation:ARB:MODulation:FSK[:DEViation]?
```

This command selects symmetric FSK frequency deviation. The acceptable range is from 0 Hz minimum to a maximum value that is dependent on the symbol rate.

*RST value: 400.0 Hz

Gate Active Polarity

```
[ :SOURce]:RADio:DMODulation:ARB:TRIGger:TYPE:GATE:ACTive LOW|HIGH
[:SOURce]:RADio:DMODulation:ARB:TRIGger:TYPE:GATE:ACTive?
```

This command toggles the polarity of the “through” or active state of a gated trigger signal. The choices are low or high. Gate active low outputs the signal when the signal level at the PATTERN TRIG IN connector is in a low state. Gate active high has the opposite effect, outputting the signal when the signal level at the PATTERN TRIG IN connector is in a high state.

*RST value: N/A

Modulation Type

```
[ :SOURce]:RADio:DMODulation:ARB:MODulation[:TYPE] BPSK|QPSK|IS95QPSK|
GRAYQPSK|OQPSK|IS95OQPSK|P4DQPSK|PSK8|PSK16|D8PSK|MSK|FSK2|FSK4|FSK8|FSK16|
C4FM|QAM4|QAM16|QAM32|QAM64|QAM256
[:SOURce]:RADio:DMODulation:ARB:MODulation[:TYPE]?
```

This command sets the modulation to one of the available formats:

BPSK	binary phase shift keying
QPSK	quadrature phase shift keying
IS95QPSK	IS95 quadrature phase shift keying
GRAYQPSK	gray coded quadrature phase shift keying
OQPSK	offset quadrature phase shift keying
IS95OQPSK	IS95 offset quadrature phase shift keying
π 4DQPSK	$\pi/4$ differential quadrature phase shift keying
PSK8	8-state phase shift keying

PSK16	16-state phase shift keying
D8PSK	differential 8-state phase shift keying
MSK	minimum shift keying
FSK2	2-level frequency shift keying
FSK4	4-level frequency shift keying
FSK8	8-level frequency shift keying
FSK16	16-level frequency shift keying
C4FM	APCO 25-compliant, 4-level frequency shift keying
QAM4	4-state quadrature amplitude modulation
QAM16	16-state quadrature amplitude modulation
QAM32	32-state quadrature amplitude modulation
QAM64	64-state quadrature amplitude modulation
QAM256	256-state quadrature amplitude modulation

*RST: $\pi/4$ DQPSK

The modulation type defaults vary, depending on the digital modulation setup:

Digital Modulation Setup	Modulation Type
NADC, PDC, PHS, APCO 25 w/CQPSK, PWT, TETRA:	$\pi/4$ DQPSK
GSM, CDPD:	MSK
EDGE:	EDGE
DECT:	2-Lvl FSK
APCO 25 w/C4FM:	C4FM

Multicarrier Setup

```
[ :SOURce]:RADio:DMODulation:ARB:SETup:MCARrier GSM|NADC|PDC|PHS|DECT|AC4Fm|
ACQPsk|CDPD|PWT|EDGE|TETRa,<num carriers>,<freq spacing>
[:SOURce]:RADio:DMODulation:ARB:SETup:MCARrier?
```

This command builds a table with the specified number of carriers and frequency spacing for one of the following multicarrier digital modulation formats:

GSM
 NADC
 PDC
 PHS
 DECT
 APCO 25 w/C4FM
 APCO 25 w/CQPSK
 CDPD
 PWT
 EDGE
 TETRA

*RST value: two NADC carriers, 500 kHz frequency offset, 0.00 dB

Multicarrier Setup: Number of Carriers

```
[ :SOURce]:RADio:DMODulation:ARB:SETup:MCARrier:TABLE:NCARriers?
```

This query returns the number of carriers configured in the current multicarrier configuration.

Multicarrier Setup: Loading User File

```
[ :SOURce]:RADio:DMODulation:ARB:SETup:MCARrier "<file name>"  
[ :SOURce]:RADio:DMODulation:ARB:SETup:MCARrier?
```

This command loads a previously defined multicarrier user file which contains information about the multicarrier setup (number of carriers, digital modulation format, frequency spacing, and power).

Multicarrier Table Setup

```
[ :SOURce]:RADio:DMODulation:ARB:SETup:MCARrier:TABLE INIT|APPend |  
<carrier_num>,GSM|NADC|PDC|PHS|DECT|AC4Fm|ACQPsk|CDPD|PWT|EDGE|TETRA |  
"<file name>",<freq_offset>,<power>
```

This command resets the multicarrier table (INIT), adds rows to an existing table (APPend), or specifies individual rows (<carrier_num>) in which to modify the frequency offset and power for one of the following multicarrier digital modulation formats:

- GSM
- NADC
- PDC
- PHS
- DECT
- APCO 25 w/C4FM
- APCO 25 w/CQPSK
- CDPD
- PWT
- EDGE
- TETRA
- user file

```
[ :SOURce]:RADio:DMODulation:ARB:SETup:MCARrier:TABLE? <carrier_num>
```

This query returns the row setup information for a specific carrier number within the table.

*RST value: two NADC carriers, 500 kHz frequency offset, 0.00 dB

Retrigger Mode State

```
[ :SOURce]:RADio:DMODulation:ARB:RETRigger ON|OFF|1|0  
[ :SOURce]:RADio:DMODulation:ARB:RETRigger?
```

This command controls the retrigger mode operating state. The choices are ON (1) or OFF (0). Retrigger mode controls what happens to a trigger that occurs while a waveform is playing. When retrigger mode is On, the waveform will retrigger at the end and play one more time. When retrigger mode is Off, the trigger will be ignored.

*RST value: On

Store Custom Modulation File

```
[ :SOURce]:RADio:DMODulation:ARB:SETup:STORE "<file name>"
```

This command enables you to store the current custom digital modulation state. The file contains information that includes the modulation type, filter and symbol rate for the custom modulation setup.

Store Multicarrier File

```
[ :SOURce]:RADio:DMODulation:ARB:SETup:MCARrier:STORE "<file name>"
```

This command enables you to store the current multicarrier setup information. The file contains information that includes the digital modulation format, number of carriers, frequency spacing, and power settings for the multicarrier setup.

Symbol Rate

```
[ :SOURce]:RADio:DMODulation:ARB:SRATE <value>  
[ :SOURce]:RADio:DMODulation:ARB:SRATE?
```

This command sets the transmission symbol rate. The acceptable range for the variable <value> is between 1 ksp/s to 12.5 Msp/s.

*RST value: 24.3000 kHz

Symbol rate defaults vary depending on the digital modulation setup configuration:

Format	Symbol Rate
DECT	1.152000 Msp/s
EDGE	270.833333 ksp/s
GSM	270.833333 ksp/s
NADC	24.300 ksp/s
PDC	21.00000 ksp/s
PHS	192.000 ksp/s
APCO 25 w/C4FM	4.800 ksp/s
APCO 25 w/CQPSK	4.800 ksp/s
CDPD	19.200 ksp/s
PWT	576.000 ksp/s
TETRA	18.000 ksp/s

Trigger Source

```
[ :SOURce ] :RADio :DMODulation :ARB :TRIGger [ :SOURce ] KEY | EXT | BUS  
[ :SOURce ] :RADio :DMODulation :ARB :TRIGger [ :SOURce ] ?
```

This command sets the trigger source. The choices include the front panel **Trigger** key, a trigger command sent over the GPIB bus, or an external trigger applied to the PATTERN TRIG IN connector.

*RST value: Ext

Trigger Type

```
[ :SOURce ] :RADio :DMODulation :ARB :TRIGger :TYPE CONT | SINGLE | GATE  
[ :SOURce ] :RADio :DMODulation :ARB :TRIGger :TYPE ?
```

This command sets the trigger type. The choices are continuous, single or gated (see [“Gate Active Polarity”](#)).

*RST value: Continuous

Dual ARB Subsystem SCPI Command Reference (Option UND Only)

The Dual ARB subsystem SCPI commands are used to set the controls and the parameters associated with the dual arbitrary waveform generator via a remote controller. These commands are for signal generators with Option UND only.

ARB State

```
[ :SOURce]:RADio:ARB[:STATe] ON|OFF|1|0  
[:SOURce]:RADio:ARB[:STATe]?
```

This command enables or disables the dual arb waveform generator capability. The choices are ON (1) or OFF (0). Executing the command `[:SOURce]:RADio:ARB[:STATe] ON` turns on the dual arbitrary generator.

*RST value: Off

ARB Reference Internal External

```
[ :SOURce]:RADio:ARB:CLOCK:REFerence[:SOURce] INTernal|EXTernal  
[:SOURce]:RADio:ARB:CLOCK:REFerence[:SOURce]?
```

This command selects either an internal or external reference for the waveform clock. If external is selected, the external frequency *must* be entered (see the Reference Frequency command) and the signal must be applied to the BASEBAND GEN REF IN connector.

*RST value: Internal

Clipping

```
[ :SOURce]:RADio:ARB:CLIPping "<file name>", IJQ|IORQ,<10-100%>[,<10-100%>]
```

This command sets the clipping level of the selected waveform segment to a percentage of its highest peak. You can clip either the composite I/Q waveform (IJQ) or I and Q separately (IORQ). (When clipping I and Q separately, the command must include percentage values for both.) The acceptable range is 10.0 to 100.00 percent with a resolution of 0.01 percent. A clipping level of 100 percent equates to no clipping.

Create Waveform Sequence

```
[ :SOURce]:RADio:ARB:SEquence "<file name>", "<waveform>", <reps>, <mkrl(1|0)>, <mkrl2(1|0)>{, "<waveform>", <reps>, <mkrl(1|0)>, <mkrl2(1|0)>}  
[ :SOURce]:RADio:ARB:SEquence? "<file name>"
```

This command is used to create a waveform sequence. You may either recall a sequence from catalog memory using the command `[:SOURce]:RADio:ARB:SEquence "<file name>"`, or you may create a new sequence by using the command `[:SOURce]:RADio:ARB:SEquence "<waveform>", <reps>{, "<waveform>", <reps>}`. For the variable "`<waveform>`", use the appropriate waveform file name. For the variable "`<reps>`", input the number of times you would like the waveform to repeat.

External Delay State

```
[ :SOURce]:RADio:ARB:TRIGger[ :SOURce]:EXTErnal:DELAy:STATE ON|OFF|1|0  
[ :SOURce]:RADio:ARB:TRIGger[ :SOURce]:EXTErnal:DELAy:STATE?
```

This command sets the operating state for the external trigger delay. The choices are on or off.

*RST value: Off

External Delay Time

```
[ :SOURce]:RADio:ARB:TRIGger[ :SOURce]:EXTErnal:DELAy <value>  
[ :SOURce]:RADio:ARB:TRIGger[ :SOURce]:EXTErnal:DELAy?
```

This command sets the time for the external trigger delay. The range of values allowed for the variable `<value>` is 2.000 microseconds through 3600 seconds.

*RST value: 2.000 msec

External Polarity

```
[ :SOURce]:RADio:ARB:TRIGger[ :SOURce]:EXTErnal:SLOPe POSitive|NEGative  
[ :SOURce]:RADio:ARB:TRIGger[ :SOURce]:EXTErnal:DELAy:STATE?
```

This command sets the polarity of the external trigger. The choices are positive or negative.

*RST value: Negative

Gate Active

```
[ :SOURce]:RADio:ARB:TRIGger:TYPE:GATE:ACTive LOW|HIGH  
[ :SOURce]:RADio:ARB:TRIGger:TYPE:GATE:ACTive?
```

This command toggles the polarity of the “through” or active state of a gated trigger signal. The choices are low or high. Gate active low will output the signal while the gate is low at the PATTERN TRIG IN connector. Gate Active High has the opposite effect, outputting the signal while the signal level at the PATTERN TRIG IN connector is in a high state.

*RST value: N/A

Markers

Defining a Marker Over a Range of Points

```
[ :SOURce]:RADio:ARB:MARKer:[SET] "<file name>",<mkr(1|2)>,<first_Point>,  
<last_point>,<skip_count>
```

This command defines a marker over a range of points on a waveform segment. The choices include:

"<file name>" - the name of the waveform segment file to which you want to add a marker

<mkr(1)> - selects marker 1

<mkr(2)> - selects marker 2

<first_Point> - defines the first point in the range over which the marker will be placed. This number must be greater than or equal to 1, and less than or equal to the total number of waveform points.

<last_point> - Defines the last point in the range over which the marker will be placed. This value must be greater than or equal to 1, and less than or equal to the total number of waveform points.

If you enter a value for either the first marker point or the last marker point that would make the first marker point occur *after* the last, the last marker point is automatically adjusted to match the first marker point.

<skip_count> - creates a repeating pattern of markers. Defining a skip count causes the marker to appear on the first point in the defined range, disappear over the number of points defined as the skip count, then reappear for one point. the pattern repeats until the end of the defined range. This enables you to set repetitively spaced markers. For example, a skip of 2 produces two points between each marker across the defined range.

Clearing Markers

```
[ :SOURce]:RADio:ARB:MARKer:CLEar "<file name>",<mkr(1|2)>,<first_Point>,  
<last_point>
```

```
[ :SOURce]:RADio:ARB:MARKer:CLEar:ALL "<file name>",<mkr(1|2)>
```

These commands clear markers from a waveform segment. The choices include:

"<file name>" - the name of the waveform segment file from which you want to clear markers

<mkr(1)> - designates marker 1 as the marker to be deleted

<mkr(2)> - designates marker 2 as the marker to be deleted

<first_Point> - defines first point in a range of points (must be greater than or equal to 1, and less than or equal to the total number of waveform points)

<last_point> - defines last point in a range of points (must be greater than or equal to 1, and less than or equal to the total number of waveform points)

If you enter a value for either the first marker point or the last marker point that would make the first marker point occur *after* the last, the last marker point is automatically adjusted to match the first marker point.

Setting Marker Polarity

```
[ :SOURce]:RADio:ARB:MARKer:POLarity NEG|POS  
[ :SOURce]:RADio:ARB:MARKer:POLarity?
```

These commands set the marker polarity as active positive or negative. The choice is:

NEG - sets the marker polarity as active negative.

POS - sets the marker polarity as active positive.

Setting Marker 2 to Blank the RF Output

```
[ :SOURce]:RADio:ARB:MARKer:RFBLank ON|OFF|1|0  
[ :SOURce]:RADio:ARB:MARKer:RFBLank?
```

These commands enable or disable RF blanking when marker 2 is low. The choice is:

ON (1) - enables RF blanking when marker 2 is low

OFF (0) - disables RF blanking when marker 2 is low

Defining a Waveform Sequence and Toggling Markers

```
[ :SOURce]:RADio:ARB:SEQuence "<file name>", "<waveform>", <reps>, <mkr1(1|0)>, <mkr2(1|0)>{, "<waveform>", <reps>, <mkr1(1|0)>, <mkr2(1|0)>}
```

```
[ :SOURce]:RADio:ARB:SEQuence? "<file name>"
```

This command defines a marker over a range of points on a waveform segment. The choices include:

"<file name>" - the name under which you want to store the new waveform sequence

"<waveform>" - name of waveform segment file

<reps> - number of repetitions of the waveform segment

<mkr1(1)> - turns marker 1 on

<mkr1(0)> - turns marker 1 off

<mkr2(1)> - turns marker 2 on

<mkr2(0)> - turns marker 2 off

Repeat the sequence as desired.

Reconstruction Filter

```
[ :SOURce]:RADio:ARB:RFILter <value>|THRough
```

```
[ :SOURce]:RADio:ARB:RFILter?
```

This command is used to modify the reconstruction filter. You may choose a filter with a cutoff frequency of 250.0 kHz, 2.500 MHz, 8.000 MHz or no filter (THRough). Acceptable values for the variable <value> are 250.0 kHz, 2.500 MHz, or 8.000 MHz.

*RST value: 2.500 MHz

Reference Frequency

```
[ :SOURce]:RADio:ARB:CLOCK:REFerence:EXTErnal:FREQuency <value>
```

```
[ :SOURce]:RADio:ARB:CLOCK:REFerence:EXTErnal:FREQuency?
```

This command sets the reference frequency of the external clock. It is only effective when you are using an external ARB reference applied to the BASEBAND GEN REF IN connector. The acceptable range for the variable <value> is 250.000 kHz to 20.000000 MHz.

*RST value: 10.0000000 MHz

Retrigger Mode State

```
[ :SOURce]:RADio:ARB:RETRigger ON|OFF|1|0  
[ :SOURce]:RADio:ARB:RETRigger?
```

This command sets the operating state of the retrigger mode. The choices are On or Off.

*RST value: On

Sample Clock

```
[ :SOURce]:RADio:ARB:CLOCK:SRATE <value>  
[ :SOURce]:RADio:ARB:CLOCK:SRATE?
```

This command adjusts the sample clock rate. The acceptable range for the variable <value> is 1.0 Hz to 40 MHz.

*RST value: 6.1440000 MHz

Scaling

```
[ :SOURce]:RADio:ARB:SCALing "<file name>", <percentage>
```

This command sets the scaling of the selected waveform segment. The acceptable range for the variable <percentage> is 1.00% to 100.00%. The resolution of the variable <percentage> is 0.01%.

*RST value: 100.00%

Select Waveform

```
[ :SOURce]:RADio:ARB:WAVEform "ARBI|SEQ:<file name>"  
[ :SOURce]:RADio:ARB:WAVEform?
```

This command selects the type of signal for the dual arbitrary waveform generator to generate. Choose between a single waveform segment (ARBI:) or a sequence of segments (SEQ:). The appropriate file name of the sequence replaces the <file name> variable.

*RST value: (*NONE*)

Trigger Source

```
[ :SOURce]:RADio:ARB:TRIGger[:SOURce] KEY|EXT|BUS  
[ :SOURce]:RADio:ARB:TRIGger[:SOURce]?
```

This command sets the trigger source. The choices include the front-panel Trigger key, a trigger command sent over the GPIB bus, or an external trigger applied to the PATTERN TRIG IN connector.

*RST value: Ext

Trigger Type

```
[ :SOURce]:RADio:ARB:TRIGger:TYPE CONTinuous|SINGle|GATE|SADVance  
[ :SOURce]:RADio:ARB:TRIGger:TYPE?
```

This command sets the trigger type. The choices are Continuous, Single, Gated, and when a waveform sequence is active, Segment Advance.

*RST value: Continuous

Multitone Waveforms

The Multitone subsystem SCPI commands are used to set the parameters associated with the multitone waveform generator. These commands apply to Option UND only.

Creating a Multitone Waveform

Four steps are used to create a multitone waveform. They are:

1. Initialize the multitone waveform setup table.
2. Assign the frequency spacing between the tones.
3. Define the number of tones in the waveform.
4. Modify the power level, phase, and state of any individual tones.

The waveform information defined in these steps is held in memory until you send the command that turns the waveform on (see [“Turning a Multitone Waveform On and Off”](#) on page 5-35).

1. Initializing the Multitone Waveform Setup Table

```
[ :SOURce ] :RADio:MTONE:ARB:SETup:TABLE:PHASe:INITialize FIXed|RANDom  
[ :SOURce ] :RADio:MTONE:ARB:SETup:TABLE:PHASe:INITialize?
```

These commands initialize the phase in the multitone waveform table. The choices include:

FIXed - sets the phase of all tones to the fixed value of 0 degrees. **FIXed** is the default value for this command.

RANDom - sets the phase of all tones to random values based on the setting on the random seed generator. The random number generator seed value may be changed using the following commands. If you want to change the random number generator seed value, use these commands before the commands shown above.

```
[ :SOURce ] :RADio:MTONE:ARB:SETup:TABLE:PHASe:INITialize:SEED FIXed|RANDom  
[ :SOURce ] :RADio:MTONE:ARB:SETup:TABLE:PHASe:INITialize:SEED?
```

These commands initialize the random number generator seed that is used to generate the random phase values in the multitone waveform table. The choices include:

- **FIXed** - sets the random number generator seed to a fixed value so that the randomly generated phase values will be the same values after each initialization of the phase. **FIXed** is the default value for this command.
- **RANDom** - sets the random number generator seed to a random values so that the randomly generated phase values will change after each initialization of the phase.

2. Assigning the Frequency Spacing between Tones

```
[ :SOURce]:RADio:MTONE:ARB:SETup:TABLE:FSPacing <freq_spacing>  
[ :SOURce]:RADio:MTONE:ARB:SETup:TABLE:FSPacing?
```

This command sets the frequency spacing between the tones. The tones are equally spaced. The `freq_spacing` value has a minimum value of 100 Hz and a maximum value of 5 MHz. When the number of tones is 5 or greater, the maximum frequency spacing value is determined by dividing 16 MHz by the number of spaces between the tones (`num_tones - 1`). The default value for frequency spacing is 10.000 kHz.

3. Defining the Number of Tones

```
[ :SOURce]:RADio:MTONE:ARB:SETup:TABLE:NTONes <num_tones>  
[ :SOURce]:RADio:MTONE:ARB:SETup:TABLE:NTONes?
```

This command defines the number of tones in the multitone waveform.

The variable is:

`num_tones` - defines the number of tones in the multitone waveform.

Range: 2 through 64

Default: 8

NOTE At this point, you have a waveform that can be used. However, to modify the power level, phase, or state of any tones, continue with step 4.

4. Modifying the Power Level, Phase, and State of any Individual Tones

```
[ :SOURce]:RADio:MTONE:ARB:SETup:TABLE:ROW <row_num> , <power> , <phase> , <state>  
[ :SOURce]:RADio:MTONE:ARB:SETup:TABLE:ROW? <row_num>
```

This command modifies a single tone of the multitone waveform. Send this command for each tone (or row) of the multitone waveform that needs to be changed.

The choices include:

`row_num` - selects the row number of the tone to be changed.

Range: 1 through `<num_tones>` that was defined in the previous step

`power` - defines the power in decibels (dB) of the selected tone.

Range: 0.00 through -80.00

`phase` - defines the phase in degrees of the selected tone.

Range: 0 through 359

`state` - defines whether the selected tone is on (1) or off (0).

Default: On (1)

NOTE An obsolete method of creating a multitone waveform exists. This method is unsupported and does not allow for the entry of the power levels for the tones. This method is a one line command.

```
[ :SOURce ]:RADio:MTONE:ARB:SETup:TABLE freq_spacing,num_tones,  
phase0,state0,phase1,state1,...  
[ :SOURce ]:RADio:MTONE:ARB:SETup:TABLE?
```

- `freq_spacing` - sets the frequency spacing between tones
- `num_tones` - defines the number of tones
- `phasen` - defines the phase of the *n*th tone
- `staten` - defines whether the *n*th tone is on (1) or off (0)

The default values and ranges for these variables are listed in the recommended procedures described in the previous method. This command has no variable to set the power of the tones.

To upgrade your signal generator firmware to most current version available, contact your nearest Agilent Technologies Sales and Service office.

Turning a Multitone Waveform On and Off

```
[ :SOURce ]:RADio:MTONE:ARB[ :STATE ] ON|OFF|1|0  
[ :SOURce ]:RADio:MTONE:ARB[ :STATE ]?
```

These commands toggle a multitone waveform. The choices include:

ON (1) - turns the waveform on.

OFF (0) - turns the waveform off. This is the default state.

Storing a Multitone Waveform

```
[ :SOURce ]:RADio:MTONE:ARB:SETup:STORe "<file name>"
```

This command stores a multitone waveform.

"<file name>" - is the name of the file to be stored in the signal generator's catalog of MTONE files.

Retrieving a Stored Multitone Waveform

```
[ :SOURce ]:RADio:MTONE:ARB:SETup "<file name>"  
[ :SOURce ]:RADio:MTONE:ARB:SETup?
```

This command retrieves a multitone waveform file.

"<file name>" - the name of a multitone waveform file stored in the signal generator's catalog of MTONE files. This information is held in memory until you send the command that turns the waveform on (see ["Turning a Multitone Waveform On and Off"](#) on page 5-35).

The following command queries the signal generator for the files stored in the catalog of MTONE files:

```
:MEMory:CATalog:MTONE?
```

6 Programming Command Cross-Reference

This section lists the Option UND and UN5 softkeys located under in the **Mode** hardkey and their corresponding SCPI commands. For a complete list of the signal generator hardkeys and softkeys and their corresponding SCPI commands, refer to the programming guide.

AWGN Softkeys

Table 6-1

Key	SCPI Command
16384	[:SOURce]:RADio:AWGN:ARB:LENGth 16384 [:SOURce]:RADio:AWGN:ARB:LENGth?
32768	[:SOURce]:RADio:AWGN:ARB:LENGth 32768 [:SOURce]:RADio:AWGN:ARB:LENGth?
65536	[:SOURce]:RADio:AWGN:ARB:LENGth 65536 [:SOURce]:RADio:AWGN:ARB:LENGth?
131072	[:SOURce]:RADio:AWGN:ARB:LENGth 131072 [:SOURce]:RADio:AWGN:ARB:LENGth?
262144	[:SOURce]:RADio:AWGN:ARB:LENGth 262144 [:SOURce]:RADio:AWGN:ARB:LENGth?
524288	[:SOURce]:RADio:AWGN:ARB:LENGth 524288 [:SOURce]:RADio:AWGN:ARB:LENGth?
1048576	[:SOURce]:RADio:AWGN:ARB:LENGth 1048576 [:SOURce]:RADio:AWGN:ARB:LENGth?
AWGN Off On	[:SOURce]:RADio:AWGN:ARB[:STATE] ON OFF 1 0 [:SOURce]:RADio:AWGN:ARB[:STATE]?
Bandwidth	[:SOURce]:RADio:AWGN:ARB:BWIDth <value> [:SOURce]:RADio:AWGN:ARB:BWIDth?
Noise Seed Fixed Random	[:SOURce]:RADio:AWGN:ARB:SEED FIXed RANDom [:SOURce]:RADio:AWGN:ARB:SEED?
Waveform Length	[:SOURce]:RADio:AWGN:ARB:LENGth <value> [:SOURce]:RADio:AWGN:ARB:LENGth?

Bluetooth Softkeys

Table 6-2

Key	SCPI Command
8 Bit Pattern	[:SOURce]:RADio:BLUETooth:ARB:DATA <#b00000000 - #b11111111> [:SOURce]:RADio:BLUETooth:ARB:DATA?
AM_ADDR	[:SOURce]:RADio:BLUETooth:ARB:AMAddr <val> [:SOURce]:RADio:BLUETooth:ARB:AMAddr?
AWGN Off On	[:SOURce]:RADio:BLUETooth:ARB:IMPairments:AWGN ON OFF 1 0 [:SOURce]:RADio:BLUETooth:ARB:IMPairments:AWGN?
BD_ADDR	[:SOURce]:RADio:BLUETooth:ARB:BDAddr <val> [:SOURce]:RADio:BLUETooth:ARB:BDAddr?
Bluetooth Off On	[:SOURce]:RADio:BLUETooth:ARB:[:STATe] ON OFF 1 0 [:SOURce]:RADio:BLUETooth:ARB:[:STATe]?
Burst Off On	[:SOURce]:RADio:BLUETooth:ARB:BURSt [:STATe] ON OFF 1 0 [:SOURce]:RADio:BLUETooth:ARB:BURSt [:STATe]?
Burst Power Ramp	[:SOURce]:RADio:BLUETooth:ARB:RSYMBOLs <1 - 10> [:SOURce]:RADio:BLUETooth:ARB:RSYMBOLs?
Clock/Gate Delay	[:SOURce]:RADio:BLUETooth:ARB:CGDelay <0 - 24999.9> [:SOURce]:RADio:BLUETooth:ARB:CGDelay?
C/N [1MHz]	[:SOURce]:RADio:BLUETooth:ARB:IMPairments:AWGN:CNR <10 dB - 40 dB> [:SOURce]:RADio:BLUETooth:ARB:IMPairments:AWGN:CNR?
Continuous PN9	[:SOURce]:RADio:BLUETooth:ARB:DATA CPN9 [:SOURce]:RADio:BLUETooth:ARB:DATA?
Drift Deviation	[:SOURce]:RADio:BLUETooth:ARB:IMPairments:DDEViation <-100.0 kHz - 100.0 kHz> [:SOURce]:RADio:BLUETooth:ARB:IMPairments:DDEViation?
Freq Drift Type	[:SOURce]:RADio:BLUETooth:ARB:IMPairments:FDType LINear SINE [:SOURce]:RADio:BLUETooth:ARB:IMPairments:FDType?
Freq Offset	[:SOURce]:RADio:BLUETooth:ARB:IMPairments:FOffset <-100.0 kHz - 100.0 kHz> [:SOURce]:RADio:BLUETooth:ARB:IMPairments:FOffset?
Impairments	[:SOURce]:RADio:BLUETooth:ARB:IMPairments ON OFF 1 0 [:SOURce]:RADio:BLUETooth:ARB:IMPairments?

Key	SCPI Command
Mod Index	[:SOURCE]:RADio:BLUEtooth:ARB:IMPairments: MINdex <0.25000 - 0.40000> [:SOURCE]:RADio:BLUEtooth:ARB:IMPairments:MINdex?
Noise Seed	[:SOURCE]:RADio:BLUEtooth:ARB:IMPairments:AWGN: NSEed <1 - 65535> [:SOURCE]:RADio:BLUEtooth:ARB:IMPairments:AWGN:NSEed?
Packet (DH1)	[:SOURCE]:RADio:BLUEtooth:ARB:PACKet DH1 [:SOURCE]:RADio:BLUEtooth:ARB:PACKet?
Payload Data	[:SOURCE]:RADio:BLUEtooth:ARB:DATA Pn9 TPN9 CPN9 <#b00000000 - #b11111111> [:SOURCE]:RADio:BLUEtooth:ARB:DATA?
Symbol Timing Err	[:SOURCE]:RADio:BLUEtooth:ARB:IMPairments: STError <-50 ppm - 50 ppm> [:SOURCE]:RADio:BLUEtooth:ARB:IMPairments:STError?
Truncated PN9	[:SOURCE]:RADio:BLUEtooth:ARB:DATA TPN9 [:SOURCE]:RADio:BLUEtooth:ARB:DATA?

CDMA Formats > IS-95A Softkeys

Table 6-3

Key	SCPI Command
250.0 kHz	[:SOURce]:RADio:ARB:RFILter 250.0 kHz [:SOURce]:RADio:ARB:RFILter?
2.500 MHz	[:SOURce]:RADio:ARB:RFILter 2.5 MHz [:SOURce]:RADio:ARB:RFILter?
8.000 MHz	[:SOURce]:RADio:ARB:RFILter 8.0 MHz [:SOURce]:RADio:ARB:RFILter?
9 Ch Fwd	[:SOURce]:RADio:CDMA:ARB:SETup FWD9 [:SOURce]:RADio:CDMA:ARB:SETup?
32 Ch Fwd	[:SOURce]:RADio:CDMA:ARB:SETup FWD32 [:SOURce]:RADio:CDMA:ARB:SETup?
64 Ch Fwd	[:SOURce]:RADio:CDMA:ARB:SETup FWD64 [:SOURce]:RADio:CDMA:ARB:SETup?
Adjust Code Domain Power	[:SOURce]:RADio:CDMA:ARB:SETup:CHANnel IS97 EQUal SCALE NONE,PIlot SYNC PAGing TRAFFic, <walsh_code>, <power_value>, <pnofs_value>,RANDOM <data_value>{,PIlot SYNC PAGing TRAFFic, <walsh_code>, <power_value>, <pnofs_value>,RANDOM <data_value>} [:SOURce]:RADio:CDMA:ARB:SETup:CHANnel?
APCO 25 C4FM	[:SOURce]:RADio:CDMA:ARB:FILTer AC4Fm [:SOURce]:RADio:CDMA:ARB:FILTer?
ARB Reference Ext Int	[:SOURce]:RADio:ARB:CLOCK:REFerence[:SOURce] INTernal EXTernal [:SOURce]:RADio:ARB:CLOCK:REFerence[:SOURce]?
Bus	[:SOURce]:RADio:CDMA:ARB:TRIGger[:SOURce] BUS [:SOURce]:RADio:CDMA:ARB:TRIGger[:SOURce]?
CDMA Off On	[:SOURce]:RADio:CDMA:ARB[:STATE] ON OFF 1 0 [:SOURce]:RADio:CDMA:ARB[:STATE]?
Chip Rate	[:SOURce]:RADio:CDMA:ARB:CRATE <value> [:SOURce]:RADio:CDMA:ARB:CRATE?
Clip I+jQ To	[:SOURce]:RADio:CDMA:ARB:CLIPping[:IJQ] <10-100%> [:SOURce]:RADio:CDMA:ARB:CLIPping[:IJQ]?
Clip I To	[:SOURce]:RADio:CDMA:ARB:CLIPping:I <10-100%> [:SOURce]:RADio:CDMA:ARB:CLIPping:I?
Clip Q To	[:SOURce]:RADio:CDMA:ARB:CLIPping:Q <10-100%> [:SOURce]:RADio:CDMA:ARB:CLIPping:Q?

Key	SCPI Command
Clip At PRE POST FIR Filter	[:SOURce]:RADio:CDMA:ARB:CLIPping:POSition PRE POST [:SOURce]:RADio:CDMA:ARB:CLIPping:POSition?
Clipping Type I+jQ I , Q 	[:SOURce]:RADio:CDMA:ARB:CLIPping:TYPE IJQ IORQ [:SOURce]:RADio:CDMA:ARB:CLIPping:TYPE?
Continuous	[:SOURce]:RADio:CDMA:ARB:TRIGger:TYPE CONTinuous [:SOURce]:RADio:CDMA:ARB:TRIGger:TYPE?
Custom CDMA State	[:SOURce]:RADio:CDMA:ARB:SETup "<file name>" [:SOURce]:RADio:CDMA:ARB:SETup?
Custom CDMA Multicarrier	[:SOURce]:RADio:CDMA:ARB:SETup:MCARrier "<file name>" [:SOURce]:RADio:CDMA:ARB:SETup:MCARrier?
Define User FIR	MEMory:DATA:FIR "<file name>","osr, coefficient{,coefficient} MEMory:DATA:FIR? "<file name>"
Edit Channel Setup	[:SOURce]:RADio:CDMA:ARB:SETup:CHANnel IS97 EQUal SCALE NONE,PILot SYNC PAGing TRAFfic,<walsh_code>,<power_value>, <pnofs_value>,RANDOM <data_value>{,PILot SYNC PAGing TRAFfic,<walsh_code>,<power_value>,<pnofs_value>,RANDOM <data_value>} [:SOURce]:RADio:CDMA:ARB:SETup:CHANnel?
Equal Powers	[:SOURce]:RADio:CDMA:ARB:SETup:CHANnel EQUal,PILot SYNC PAGing TRAFfic, <walsh_code>,<power_value>,<pnofs_value>, RANDOM <data_value>{,PILot SYNC PAGing TRAFfic, <walsh_code>,<power_value>,<pnofs_value>,RANDOM <data_value>} [:SOURce]:RADio:CDMA:ARB:SETup:CHANnel?
Ext	[:SOURce]:RADio:CDMA:ARB:TRIGger[:SOURce] EXT [:SOURce]:RADio:CDMA:ARB:TRIGger[:SOURce]?
Ext Polarity Neg Pos	[:SOURce]:RADio:CDMA:ARB:TRIGger[:SOURce]:EXTernal:SLOPe POSitive NEGative [:SOURce]:RADio:CDMA:ARB:TRIGger[:SOURce]:EXTernal:SLOPe?
Ext Delay Off On	[:SOURce]:RADio:CDMA:ARB:TRIGger[:SOURce]:EXTernal:DElay: STATE ON OFF 1 0 [:SOURce]:RADio:CDMA:ARB:TRIGger[:SOURce]:EXTernal:DElay: STATE?
Ext Delay Time	[:SOURce]:RADio:CDMA:ARB:TRIGger[:SOURce]:EXTernal:DElay <value> [:SOURce]:RADio:CDMA:ARB:TRIGger[:SOURce]:EXTernal:DElay?
Filter Alpha	[:SOURce]:RADio:CDMA:ARB:FILter:ALPHa <value> [:SOURce]:RADio:CDMA:ARB:FILter:ALPHa?
Filter BbT	[:SOURce]:RADio:CDMA:ARB:FILter:BBT <value> [:SOURce]:RADio:CDMA:ARB:FILter:BBT?

Key	SCPI Command
Gate Active	[:SOURce]:RADio:CDMA:ARB:TRIGger:TYPE:GATE:ACTive LOW HIGH [:SOURce]:RADio:CDMA:ARB:TRIGger:TYPE:GATE:ACTive?
Gated	[:SOURce]:RADio:CDMA:ARB:TRIGger:TYPE GATE [:SOURce]:RADio:CDMA:ARB:TRIGger:TYPE?
Gaussian	[:SOURce]:RADio:CDMA:ARB:FILTer GAUSSain [:SOURce]:RADio:CDMA:ARB:FILTer?
IS-95	[:SOURce]:RADio:CDMA:ARB:FILTer IS95 [:SOURce]:RADio:CDMA:ARB:FILTer?
IS-95 Mod	[:SOURce]:RADio:CDMA:ARB:FILTer IS95_MOD [:SOURce]:RADio:CDMA:ARB:FILTer?
IS-95 Mod w/EQ	[:SOURce]:RADio:CDMA:ARB:FILTer IS95_MOD_EQ [:SOURce]:RADio:CDMA:ARB:FILTer?
IS-95 w/EQ	[:SOURce]:RADio:CDMA:ARB:FILTer IS95_EQ [:SOURce]:RADio:CDMA:ARB:FILTer?
IS-97 Levels	[:SOURce]:RADio:CDMA:ARB:SETup:CHANnel IS97,PILot SYNC PAGing TRAFFic,<walsh_code>,<power_value>,<pnofs_value>, RANDom <data_value>{,PILot SYNC PAGing TRAFFic, <walsh_code>,<power_value>,<pnofs_value>,RANDom <data_value>} [:SOURce]:RADio:CDMA:ARB:SETup:CHANnel?
IS-2000 SR3 DS	[:SOURce]:RADio:CDMA:ARB:FILTer IS2000SR3DS [:SOURce]:RADio:CDMA:ARB:FILTer?
Modulation Index	[:SOURce]:RADio:BLUetooth:ARB:MINdex <val> [:SOURce]:RADio:BLUetooth:ARB:MINdex?
Multicarrier Define	[:SOURce]:RADio:CDMA:ARB:SETup:MCARrier:TABLE {FWD9 FWD32 FWD64 PILot CUSTom,"<file name>" ",<freq_offset>, <power>} [:SOURce]:RADio:CDMA:ARB:SETup:MCARrier:TABLE?
Multicarrier Off On	[:SOURce]:RADio:CDMA:ARB:SETup MCARrier [:SOURce]:RADio:CDMA:ARB:SETup?
Nyquist	[:SOURce]:RADio:CDMA:ARB:FILTer NYQuist [:SOURce]:RADio:CDMA:ARB:FILTer?
Optimize FIR For EVM ACP	[:SOURce]:RADio:CDMA:ARB:FILTer:CHANnel EVM ACP [:SOURce]:RADio:CDMA:ARB:FILTer:CHANnel?
Oversample Ratio	[:SOURce]:RADio:CDMA:ARB:OSAMple <value> [:SOURce]:RADio:CDMA:ARB:OSAMple?

Key	SCPI Command
Paging	[:SOURCE]:RADio:CDMA:ARB:SETup:CHANnel NONE,PAGing, <walsh_code>,<power_value>,<pnofs_value>,RANDOM <data_value>{,PILot SYNC PAGing TRAFfic,<walsh_code>, <power_value>,<pnofs_value>,RANDOM <data_value>} [:SOURCE]:RADio:CDMA:ARB:SETup:CHANnel?
Pilot (in the CDMA Select menu)	[:SOURCE]:RADio:CDMA:ARB:SETup: PILot [:SOURCE]:RADio:CDMA:ARB:SETup?
Pilot (in the Channel Select menu)	[:SOURCE]:RADio:CDMA:ARB:SETup:CHANnel NONE,PILot, <walsh_code>,<power_value>,<pnofs_value>,RANDOM <data_value> {,PILot SYNC PAGing TRAFfic,<walsh_code>, <power_value>,<pnofs_value>,RANDOM <data_value>} [:SOURCE]:RADio:CDMA:ARB:SETup:CHANnel?
Random	[:SOURCE]:RADio:CDMA:ARB:SETup:CHANnel NONE,PILot, <walsh_code>,<power_value>,<pnofs_value>,RANDOM <data_value> {,PILot SYNC PAGing TRAFfic,<walsh_code>, <power_value>,<pnofs_value>,RANDOM} [:SOURCE]:RADio:CDMA:ARB:SETup:CHANnel?
Reconstruction Filter	[:SOURCE]:RADio:CDMA:ARB:FILTer <value> THRough [:SOURCE]:RADio:CDMA:ARB:FILTer?
Rectangle	[:SOURCE]:RADio:CDMA:ARB:FILTer RECTangle [:SOURCE]:RADio:CDMA:ARB:FILTer?
Reference Frequency	[:SOURCE]:RADio:ARB:CLOCK:REFerence:EXTernal:FREQuency <value> [:SOURCE]:RADio:ARB:CLOCK:REFerence:EXTernal:FREQuency?
Restore Default Filter	[:SOURCE]:RADio:CDMA:ARB:FILTer IS95_MOD_EQ [:SOURCE]:RADio:CDMA:ARB:FILTer?
Retrigger Mode Off On	[:SOURCE]:RADio:CDMA:ARB:RETRigger ON OFF 1 0 [:SOURCE]:RADio:CDMA:ARB:RETRigger?
Reverse	[:SOURCE]:RADio:CDMA:ARB:SETup REVerse [:SOURCE]:RADio:CDMA:ARB:SETup?
Root Nyquist	[:SOURCE]:RADio:CDMA:ARB:FILTer RNYQuist [:SOURCE]:RADio:CDMA:ARB:FILTer?
Scale To 0dB	[:SOURCE]:RADio:CDMA:ARB:SETup:CHANnel SCALE,PILot SYNC PAGing TRAFfic,<walsh_code>,<power_value>,<pnofs_value>, RANDOM <data_value>{,PILot SYNC PAGing TRAFfic, <walsh_code>,<power_value>,<pnofs_value>,RANDOM <data_value>} [:SOURCE]:RADio:CDMA:ARB:SETup:CHANnel?
Select	[:SOURCE]:RADio:CDMA:ARB:FILTer RNYQuist NYQuist GAUSSian RECTangle IS95 IS95_EQ IS95_MOD IS95_MOD_EQ "<file name>" [:SOURCE]:RADio:CDMA:ARB:FILTer?

Key	SCPI Command
Select File	[:SOURce]:RADIo:CDMA:ARB:FILTer "<file name>" [:SOURce]:RADIo:CDMA:ARB:FILTer?
Setup Select	[:SOURce]:RADIo:CDMA:ARB:SETup FWD9 FWD32 FWD64 PILot REVerse MCARrier "<file name>" [:SOURce]:RADIo:CDMA:ARB:SETup? [:SOURce]:RADIo:CDMA:ARB:SETup:MCARrier CAR3 CAR4 "<file name>" [:SOURce]:RADIo:CDMA:ARB:SETup:MCARrier?
Single	[:SOURce]:RADIo:CDMA:ARB:TRIGger:TYPE SINGLE [:SOURce]:RADIo:CDMA:ARB:TRIGger:TYPE?
Store Custom CDMA State	[:SOURce]:RADIo:CDMA:ARB:SETup:STORE "<file name>"
Store Custom Multicarrier	[:SOURce]:RADIo:CDMA:ARB:SETup:MCARrier:STORE "<file name>"
Sync	[:SOURce]:RADIo:CDMA:ARB:SETup:CHANnel NONE, SYNC, <walsh_code>, <power_value>, <pnofs_value>, RANDom <data_value> {, PILot SYNC PAGing TRAFFic, <walsh_code>, <power_value>, <pnofs_value>, RANDom <data_value>} [:SOURce]:RADIo:CDMA:ARB:SETup:CHANnel?
Through	[:SOURce]:RADIo:CDMA:ARB:RFILTer THROugh [:SOURce]:RADIo:CDMA:ARB:RFILTer?
Traffic	[:SOURce]:RADIo:CDMA:ARB:SETup:CHANnel NONE, TRAFFic, <walsh_code>, <power_value>, <pnofs_value>, RANDom <data_value> {, PILot SYNC PAGing TRAFFic, <walsh_code>, <power_value>, <pnofs_value>, RANDom <data_value>} [:SOURce]:RADIo:CDMA:ARB:SETup:CHANnel?
Trigger	[:SOURce]:RADIo:CDMA:ARB:TRIGger:TYPE CONTInuous SINGLE GATE [:SOURce]:RADIo:CDMA:ARB:TRIGger:TYPE?
Trigger Key	[:SOURce]:RADIo:CDMA:ARB:TRIGger[:SOURce] KEY [:SOURce]:RADIo:CDMA:ARB:TRIGger[:SOURce]?
Trigger Source	[:SOURce]:RADIo:CDMA:ARB:TRIGger[:SOURce] KEY EXT BUS [:SOURce]:RADIo:CDMA:ARB:TRIGger[:SOURce]?
Waveform Length	[:SOURce]:RADIo:CDMA:ARB:WLENgth <value> [:SOURce]:RADIo:CDMA:ARB:WLENgth?
WCDMA	[:SOURce]:RADIo:CDMA:ARB:FILTer WCDMa [:SOURce]:RADIo:CDMA:ARB:FILTer?

Dual ARB Softkeys

Table 6-4

Key	SCPI Command
# Skipped Points	[:SOURce]:RADio:ARB:MARKer[:SET] "<file name>", <mkr(1 2)>, <first_point>, <last_point>, <skip_count>
250.0 kHz	[:SOURce]:RADio:ARB:RFILter 2.5 MHz [:SOURce]:RADio:ARB:RFILter?
2.500 MHz	[:SOURce]:RADio:ARB:RFILter 8.0 MHz [:SOURce]:RADio:ARB:RFILter?
8.000 MHz	[:SOURce]:RADio:ARB:RFILter 250.0 kHz [:SOURce]:RADio:ARB:RFILter?
Apply to Waveform	[:SOURce]:RADio:ARB:MARKer:CLEar "<file name>", <mkr(1 2)>,<first_point>,<last_point> [:SOURce]:RADio:ARB:SCALing "file name",<percentage>
Clip I+jQ To	[:SOURce]:RADio:ARB:CLIPping "<file name>", I JQ I ORQ,<10-100%>[,<10-100%>]
ARB Off On	[:SOURce]:RADio:ARB[:STATE] ON OFF 1 0 [:SOURce]:RADio:ARB[:STATE]?
ARB Reference Ext Int	[:SOURce]:RADio:ARB:CLOCK:REFerence[:SOURce] INTernal EXTernal [:SOURce]:RADio:ARB:CLOCK:REFerence[:SOURce]?
ARB Sample Clock	[:SOURce]:RADio:ARB:CLOCK:SRATE <value> [:SOURce]:RADio:ARB:CLOCK:SRATE?
Build New Waveform Sequence	[:SOURce]:RADio:ARB:SEQuence <filename>,<waveform>,<reps>,<mkr1(1 0)>,<mkr2(1 0)> {,<waveform>,<reps>,<mkr1(1 0)>,<mkr2(1 0)>} [:SOURce]:RADio:ARB:SEQuence? <filename>
Bus	[:SOURce]:RADio:ARB:TRIGger[:SOURce] BUS [:SOURce]:RADio:ARB:TRIGger[:SOURce]?
Clip I+jQ To	[:SOURce]:RADio:ARB:CLIPping "<file name>", I JQ I ORQ,<10-100%>[,<10-100%>]
Clip I To	[:SOURce]:RADio:ARB:CLIPping "<file name>", I JQ I ORQ,<10-100%>[,<10-100%>]
Clip Q To	[:SOURce]:RADio:ARB:CLIPping "<file name>", I JQ I ORQ,<10-100%>[,<10-100%>]
Clipping Type I+jQ I , Q	[:SOURce]:RADio:ARB:CLIPping "<file name>", I JQ I ORQ,<10-100%>[,<10-100%>]

Key	SCPI Command
Continuous	[:SOURce]:RADio:ARB:TRIGger:TYPE CONTInuous [:SOURce]:RADio:ARB:TRIGger:TYPE?
Delete All ARB Files	:MMEMory:DELeTe:ARB
Delete All NVARB Files	:MMEMory:DELeTe:NVARb
Ext	[:SOURce]:RADio:ARB:TRIGger[:SOURce] EXT [:SOURce]:RADio:ARB:TRIGger[:SOURce]?
Ext Polarity Neg Pos	[:SOURce]:RADio:ARB:TRIGger[:SOURce]:EXTernal:SLOPe POSitive NEGative [:SOURce]:RADio:ARB:TRIGger[:SOURce]:EXTernal:SLOPe?
Ext Delay Off On	[:SOURce]:RADio:ARB:TRIGger[:SOURce]:EXTernal:DELAy: STATe ON OFF 1 0 [:SOURce]:RADio:ARB:TRIGger[:SOURce]:EXTernal:DELAy: STATe?
Ext Delay Time	[:SOURce]:RADio:ARB:TRIGger[:SOURce]:EXTernal:DELAy <value>[:SOURce]:RADio:ARB:TRIGger [:SOURce]:EXTernal:DELAy?
First Marker Point	[:SOURce]:RADio:ARB:MARKer:[SET] "<file name>", <mkr(1 2)>,<first_point>,<last_point>,<skip_count> [:SOURce]:RADio:ARB:MARKer:CLEar "<file name>", <mkr(1 2)>,<first_point>,<last_point>
Gated	[:SOURce]:RADio:ARB:TRIGger:TYPE GATE [:SOURce]:RADio:ARB:TRIGger:TYPE?
Gate Active	[:SOURce]:RADio:ARB:TRIGger:TYPE:GATE:ACTive LOW HIGH [:SOURce]:RADio:ARB:TRIGger:TYPE:GATE:ACTive?
Last Marker Point	[:SOURce]:RADio:ARB:MARKer:[SET] "<file name>", <mkr(1 2)>,<first_point>,<last_point>,<skip_count> [:SOURce]:RADio:ARB:MARKer:CLEar "<file name>", <mkr(1 2)>,<first_point>,<last_point>
Marker 1 2	[:SOURce]:RADio:ARB:MARKer:[SET] "<file name>", <mkr(1 2)>,<first_point>,<last_point>,<skip_count>
Marker Polarity Neg Pos	[:SOURce]:RADio:ARB:MARKer:POLarity NEG POS [:SOURce]:RADio:ARB:MARKer:POLarity?
Marker 2 To RF Blank Off On	[:SOURce]:RADio:ARB:MARKer:RFBLank ON OFF 1 0 [:SOURce]:RADio:ARB:MARKer:RFBLank?
Reconstruction Filter	[:SOURce]:RADio:ARB:RFILter <value> THROugh [:SOURce]:RADio:ARB:RFILter?

Key	SCPI Command
Reference Frequency	[:SOURce]:RADio:ARB:CLOCK:REFerence:EXTernal:FREQuency <value> [:SOURce]:RADio:ARB:CLOCK:REFerence:EXTernal: FREQuency?
Rename Segment	:MMEMemory:MOVE "ARBI:<src_file>","ARBI:<dest_file>" :MMEMemory:MOVE "NVARBI:<src_file>","NVARBI:<dest_file>"
Retrigger Mode Off On	[:SOURce]:RADio:ARB:RETRigger ON OFF 1 0 [:SOURce]:RADio:ARB:RETRigger?
Scaling	[:SOURce]:RADio:ARB:SCALing "<file name>",<percentage>
Segment Advance	[:SOURce]:RADio:ARB:TRIGger:TYPE SADVance [:SOURce]:RADio:ARB:TRIGger:TYPE?
Select Waveform (ARBI: or SEQ:)	[:SOURce]:RADio:ARB:WAVEform "ARBI SEQ:<file name>" [:SOURce]:RADio:ARB:WAVEform?
Set Markers	[:SOURce]:RADio:ARB:MARKer:[SET] "<file name>",<mkr(1 2)>,<first_point>,<last_point>,<skip_count>
Set Marker Off All Points	[:SOURce]:RADio:ARB:MARKer:CLEar:ALL "<file name>",<mkr(1 2)>
Set Marker Off Range Of Points	[:SOURce]:RADio:ARB:MARKer:CLEar "<file name>",<mkr(1 2)>,<first_point>,<last_point>
Set Marker On First Point	[:SOURce]:RADio:ARB:MARKer:[SET] "<file name>",<mkr(1 2)>,<first_point>,<last_point>,<skip_count>
Set Marker On Range Of Points	[:SOURce]:RADio:ARB:MARKer:[SET] "<file name>",<mkr(1 2)>,<first_point>,<last_point>,<skip_count>
Set Scaling	[:SOURce]:RADio:ARB:SCALing "<file name>",<percentage>
Single	[:SOURce]:RADio:ARB:TRIGger:TYPE SINGLE [:SOURce]:RADio:ARB:TRIGger:TYPE?
Through	[:SOURce]:RADio:ARB:RFILter THROUGH [:SOURce]:RADio:ARB:RFILter?
Toggle Marker 1	[:SOURce]:RADio:ARB:SEQuence "<file name>",<waveform>",<reps>,<mkr1(1 0)>,<mkr2(1 0)>{,"<waveform>",<reps>,<mkr1(1 0)>,<mkr2(1 0)>} [:SOURce]:RADio:ARB:SEQuence? "<file name>"
Toggle Marker 2	[:SOURce]:RADio:ARB:SEQuence "<file name>",<waveform>",<reps>,<mkr1(1 0)>,<mkr2(1 0)>{,"<waveform>",<reps>,<mkr1(1 0)>,<mkr2(1 0)>} [:SOURce]:RADio:ARB:SEQuence? "<file name>"

Key	SCPI Command
Toggle Markers	<pre>[:SOURce]:RADio:ARB:MARKer:[SET] "<file name>", <mkcr(1 2)>,<first_point>,<last_point>,<skip_count> [:SOURce]:RADio:ARB:MARKer:CLEar:ALL "<file name>", <mkcr(1 2)></pre>
Trigger	<pre>[:SOURce]:RADio:ARB:TRIGger:TYPE CONTinuous SINGLE GATE [:SOURce]:RADio:ARB:TRIGger:TYPE?</pre>
Trigger Key	<pre>[:SOURce]:RADio:ARB:TRIGger[:SOURce] KEY [:SOURce]:RADio:ARB:TRIGger[:SOURce]?</pre>
Trigger Source	<pre>[:SOURce]:RADio:ARB:TRIGger[:SOURce] KEY EXT BUS [:SOURce]:RADio:ARB:TRIGger[:SOURce]?</pre>

Multitone Softkeys

Table 6-5

Key	SCPI Command
Apply Multitone	[:SOURCE] :RADio:MTONE:ARB [:STATE] ON 1
Edit Phase <i>(this command is no longer supported; refer to "Multitone Waveforms" in Chapter 5.)</i>	[:SOURCE] :RADio:MTONE:ARB:SETup:TABLE freq_spacing, num_tones, phase0, state0, phase1, state1, ... [:SOURCE] :RADio:MTONE:ARB:SETup:TABLE?
Freq Spacing	[:SOURCE] :RADio:MTONE:ARB:SETup:TABLE:FSPacing freq_spacing [:SOURCE] :RADio:MTONE:ARB:SETup:TABLE:FSPacing?
Load From Selected File	[:SOURCE] :RADio:MTONE:ARB:SETup "<file name>" [:SOURCE] :RADio:MTONE:ARB:SETup?
MTONE	:MEMory:CATalog:MTONE?
Multitone Off On	[:SOURCE] :RADio:MTONE:ARB [:STATE] ON OFF 1 0 [:SOURCE] :RADio:MTONE:ARB [:STATE] ?
Number of Tones	[:SOURCE] :RADio:MTONE:ARB:SETup:TABLE:NTONES num_tones [:SOURCE] :RADio:MTONE:ARB:SETup:TABLE:NTONES?
Store To File	[:SOURCE] :RADio:MTONE:ARB:SETup:STORE "<file name>"
Toggle State	[:SOURCE] :RADio:MTONE:ARB:SETup:TABLE:ROW row_number, power, phase, state [:SOURCE] :RADio:MTONE:ARB:SETup:TABLE:ROW?

Other Formats Softkeys

Table 6-6

Key	SCPI Command
$\pi/4$ DQPSK	[:SOURce]:RADio:DMODulation:ARB:MODulation [:TYPE] P4DQPSK [:SOURce]:RADio:DMODulation:ARB:MODulation[:TYPE]?
# of Carriers	[:SOURce]:RADio:DMODulation:ARB:SETup:MCARrier:TABLE: NCARriers?
2-Lvl FSK	[:SOURce]:RADio:DMODulation:ARB:MODulation[:TYPE] FSK2 [:SOURce]:RADio:DMODulation:ARB:MODulation[:TYPE]?
4-Lvl FSK	[:SOURce]:RADio:DMODulation:ARB:MODulation[:TYPE] FSK4 [:SOURce]:RADio:DMODulation:ARB:MODulation[:TYPE]?
4QAM	[:SOURce]:RADio:DMODulation:ARB:MODulation[:TYPE] QAM4 [:SOURce]:RADio:DMODulation:ARB:MODulation[:TYPE]?
8-Lvl FSK	[:SOURce]:RADio:DMODulation:ARB:MODulation[:TYPE] FSK8 [:SOURce]:RADio:DMODulation:ARB:MODulation[:TYPE]?
8PSK	[:SOURce]:RADio:DMODulation:ARB:MODulation[:TYPE] PSK8 [:SOURce]:RADio:DMODulation:ARB:MODulation[:TYPE]?
16-Lvl FSK	[:SOURce]:RADio:DMODulation:ARB:MODulation[:TYPE] FSK16 [:SOURce]:RADio:DMODulation:ARB:MODulation[:TYPE]?
16PSK	[:SOURce]:RADio:DMODulation:ARB:MODulation[:TYPE] PSK16 [:SOURce]:RADio:DMODulation:ARB:MODulation[:TYPE]?
16QAM	[:SOURce]:RADio:DMODulation:ARB:MODulation[:TYPE] QAM16 [:SOURce]:RADio:DMODulation:ARB:MODulation[:TYPE]?
32QAM	[:SOURce]:RADio:DMODulation:ARB:MODulation[:TYPE] QAM32 [:SOURce]:RADio:DMODulation:ARB:MODulation[:TYPE]?
64QAM	[:SOURce]:RADio:DMODulation:ARB:MODulation[:TYPE] QAM64 [:SOURce]:RADio:DMODulation:ARB:MODulation[:TYPE]?
256QAM	[:SOURce]:RADio:DMODulation:ARB:MODulation [:TYPE] QAM256 [:SOURce]:RADio:DMODulation:ARB:MODulation[:TYPE]?
APCO 25 C4FM	[:SOURce]:RADio:DMODulation:ARB:FILTer AC4Fm [:SOURce]:RADio:DMODulation:ARB:FILTer?
APCO 25 w/C4FM	[:SOURce]:RADio:DMODulation:ARB:SETup AC4FM [:SOURce]:RADio:DMODulation:ARB:SETup? [:SOURce]:RADio:DMODulation:ARB:SETup:MCARrier AC4FM [:SOURce]:RADio:DMODulation:ARB:SETup:MCARrier?

Key	SCPI Command
APCO 25 w/CQPSK	[:SOURce]:RADio:DMODulation:ARB:SETup ACQPsk [:SOURce]:RADio:DMODulation:ARB:SETup? [:SOURce]:RADio:DMODulation:ARB:SETup:MCARrier ACQPsk [:SOURce]:RADio:DMODulation:ARB:SETup:MCARrier?
BPSK	[:SOURce]:RADio:DMODulation:ARB:MODulation[:TYPE] BPSK [:SOURce]:RADio:DMODulation:ARB:MODulation[:TYPE]?
Bus	[:SOURce]:RADio:DMODulation:ARB:TRIGger[:SOURce] BUS [:SOURce]:RADio:DMODulation:ARB:TRIGger[:SOURce]?
C4FM	[:SOURce]:RADio:DMODulation:ARB:MODulation[:TYPE] C4FM [:SOURce]:RADio:DMODulation:ARB:MODulation[:TYPE]?
Carrier Setup	[:SOURce]:RADio:DMODulation:ARB:SETup:MCARrier GSM NADC PDC PHS DECT AC4Fm ACPQsk CDPD PWT EDGE TETRA [:SOURce]:RADio:DMODulation:ARB:SETup:MCARrier?
CDPD	[:SOURce]:RADio:DMODulation:ARB:SETup CDPD [:SOURce]:RADio:DMODulation:ARB:SETup? [:SOURce]:RADio:DMODulation:ARB:SETup:MCARrier CDPD [:SOURce]:RADio:DMODulation:ARB:SETup:MCARrier?
Continuous	[:SOURce]:RADio:DMODulation:ARB:TRIGger:TYPE CONT [:SOURce]:RADio:DMODulation:ARB:TRIGger:TYPE?
Custom Digital Mod State	[:SOURce]:RADio:DMODulation:ARB:SETup "<file name>" [:SOURce]:RADio:DMODulation:ARB:SETup? [:SOURce]:RADio:DMODulation:ARB:SETup:MCARrier "<file name>" [:SOURce]:RADio:DMODulation:ARB:SETup:MCARrier?
D8PSK	[:SOURce]:RADio:DMODulation:ARB:MODulation[:TYPE] D8PSK [:SOURce]:RADio:DMODulation:ARB:MODulation[:TYPE]?
DECT	[:SOURce]:RADio:DMODulation:ARB:SETup DECT [:SOURce]:RADio:DMODulation:ARB:SETup? [:SOURce]:RADio:DMODulation:ARB:SETup:MCARrier DECT [:SOURce]:RADio:DMODulation:ARB:SETup:MCARrier?
Define User FIR	:MEMory:DATA:FIR "<file name>",osr,coefficient{,coefficient} :MEMory:DATA:FIR? "<file name>"
Digital Modulation Off On	[:SOURce]:RADio:DMODulation:ARB[:STATE] ON OFF 1 0 [:SOURce]:RADio:DMODulation:ARB[:STATE]?
EDGE	[:SOURce]:RADio:DMODulation:ARB:SETup EDGE [:SOURce]:RADio:DMODulation:ARB:SETup? [:SOURce]:RADio:DMODulation:ARB:SETup:MCARrier EDGE [:SOURce]:RADio:DMODulation:ARB:SETup:MCARrier?

Key	SCPI Command
Ext	[:SOURce]:RADio:DMODulation:ARB:TRIGger[:SOURce] EXT [:SOURce]:RADio:DMODulation:ARB:TRIGger[:SOURce]?
Ext Delay Off On	[:SOURce]:RADio:DMODulation:ARB:TRIGger[:SOURce]: EXTernal:DELay:STATe ON OFF 1 0 [:SOURce]:RADio:DMODulation:ARB:TRIGger[:SOURce]: EXTernal:DELay:STATe?
Ext Delay Time	[:SOURce]:RADio:DMODulation:ARB:TRIGger[:SOURce]: EXTernal:DELay <value> [:SOURce]:RADio:DMODulation:ARB:TRIGger[:SOURce]: EXTernal:DELay?
Ext Polarity Neg Pos	[:SOURce]:RADio:DMODulation:ARB:TRIGger[:SOURce]: EXTernal:SLOPe POSitive NEGative [:SOURce]:RADio:DMODulation:ARB:TRIGger[:SOURce]: EXTernal:SLOPe?
Filter	[:SOURce]:RADio:DMODulation:ARB:FILTer: RNYQuist NYQuist GAUSSian RECTangle\IS95 IS95_EQ IS95_MOD IS95_MOD_EQ WCDma AC4FM IS2000SR3DS "<file name>" [:SOURce]:RADio:DMODulation:ARB:FILTer?
Filter Alpha	[:SOURce]:RADio:DMODulation:ARB:FILTer:ALPHa <value> [:SOURce]:RADio:DMODulation:ARB:FILTer:ALPHa?
Filter BbT	[:SOURce]:RADio:DMODulation:ARB:FILTer:BBT <value> [:SOURce]:RADio:DMODulation:ARB:FILTer:BBT?
Freq Dev	[:SOURce]:RADio:DMODulation:ARB:MODulation:FSK [:DEViation] <val><unit> [:SOURce]:RADio:DMODulation:ARB:MODulation:FSK [:DEViation]?
Freq Spacing	[:SOURce]:RADio:DMODulation:ARB:SETup: MCArrier [<freq spacing>] [:SOURce]:RADio:DMODulation:ARB:SETup:MCArrier?
FSK	[:SOURce]:RADio:DMODulation:ARB:MODulation[:TYPE] FSK2 FSK4 FSK8 FSK16 C4FM [:SOURce]:RADio:DMODulation:ARB:MODulation[:TYPE]?
Gate Active Low High	[:SOURce]:RADio:DMODulation:ARB:TRIGger:TYPE:GATE: ACTive LOW HIGH [:SOURce]:RADio:DMODulation:ARB:TRIGger:TYPE:GATE: ACTive?
Gated	[:SOURce]:RADio:DMODulation:ARB:TRIGger:TYPE GATE [:SOURce]:RADio:DMODulation:ARB:TRIGger:TYPE?
Gaussian	[:SOURce]:RADio:DMODulation:ARB:FILTer GAUSSian [:SOURce]:RADio:DMODulation:ARB:FILTer?
Gray Coded QPSK	[:SOURce]:RADio:DMODulation:ARB:MODulation[:TYPE] GRAYQPSK [:SOURce]:RADio:DMODulation:ARB:MODulation[:TYPE]?

Key	SCPI Command
GSM	[:SOURce]:RADio:DMODulation:ARB:SETup GSM [:SOURce]:RADio:DMODulation:ARB:SETup? [:SOURce]:RADio:DMODulation:ARB:SETup:MCARrier GSM [:SOURce]:RADio:DMODulation:ARB:SETup:MCARrier?
Initialize Table	[:SOURce]:RADio:DMODulation:ARB:SETup:MCARrier:TABLE INIT
IS-95	[:SOURce]:RADio:DMODulation:ARB:FILTer IS95 [:SOURce]:RADio:DMODulation:ARB:FILTer?
IS-95 Mod	[:SOURce]:RADio:DMODulation:ARB:FILTer IS95_MOD [:SOURce]:RADio:DMODulation:ARB:FILTer?
IS-95 Mod w/EQ	[:SOURce]:RADio:DMODulation:ARB:FILTer IS95_MOD_EQ [:SOURce]:RADio:DMODulation:ARB:FILTer?
IS-95 w/EQ	[:SOURce]:RADio:DMODulation:ARB:FILTer IS95_EQ [:SOURce]:RADio:DMODulation:ARB:FILTer?
IS95 OQPSK	[:SOURce]:RADio:DMODulation:ARB:MODulation[:TYPE] IS95OQPSK [:SOURce]:RADio:DMODulation:ARB:MODulation[:TYPE]?
IS95 QPSK	[:SOURce]:RADio:DMODulation:ARB:MODulation[:TYPE] IS95QPSK [:SOURce]:RADio:DMODulation:ARB:MODulation[:TYPE]?
IS-2000 SR3 DS	[:SOURce]:RADio:DMODulation:ARB:FILTer IS2000SR3DS [:SOURce]:RADio:DMODulation:ARB:FILTer?
Load/Store	[:SOURce]:RADio:DMODulation:ARB:SETup:MCARrier: STORE "<file name>"
Modulation Type	[:SOURce]:RADio:DMODulation:ARB:MODulation[:TYPE] BPSK QPSK IS95QPSK GRAYQPSK OQPSK IS95OQPSK P4DQPSK PSK8 PSK16 D8PSK MSK FSK2 FSK4 FSK8 FSK16 C4FM QAM4 QAM16 QAM32 QAM64 QAM256 [:SOURce]:RADio:DMODulation:ARB:MODulation[:TYPE]?
MSK	[:SOURce]:RADio:DMODulation:ARB:MODulation[:TYPE] MSK [:SOURce]:RADio:DMODulation:ARB:MODulation[:TYPE]?
Multicarrier Define	[:SOURce]:RADio:DMODulation:ARB:SETup:MCARrier GSM NADC PDC PHS DECT AC4Fm ACPQsk CDPD PWT EDGE TETRA, "<file name>",<num carriers>,<freq spacing>] [:SOURce]:RADio:DMODulation:ARB:SETup:MCARrier?
Multicarrier Off On	[:SOURce]:RADio:DMODulation:ARB:SETup MCARrier [:SOURce]:RADio:DMODulation:ARB:SETup?
NADC	[:SOURce]:RADio:DMODulation:ARB:SETup NADC [:SOURce]:RADio:DMODulation:ARB:SETup? [:SOURce]:RADio:DMODulation:ARB:SETup:MCARrier NADC [:SOURce]:RADio:DMODulation:ARB:SETup:MCARrier?

Key	SCPI Command
Nyquist	[:SOURce]:RADio:DMODulation:ARB:FILTer NYQuist [:SOURce]:RADio:DMODulation:ARB:FILTer?
Optimize FIR For EVM ACP	[:SOURce]:RADio:DMODulation:ARB:FILTer:CHANnel EVM ACP [:SOURce]:RADio:DMODulation:ARB:FILTer:CHANnel?
OQPSK	[:SOURce]:RADio:DMODulation:ARB:MODulation[:TYPE] OQPSK [:SOURce]:RADio:DMODulation:ARB:MODulation[:TYPE]?
Oversample Ratio	:MEMory:DATA:FIR "<file name>",osr
PDC	[:SOURce]:RADio:DMODulation:ARB:SETup PDC [:SOURce]:RADio:DMODulation:ARB:SETup? [:SOURce]:RADio:DMODulation:ARB:SETup:MCARrier PDC [:SOURce]:RADio:DMODulation:ARB:SETup:MCARrier?
PHS	[:SOURce]:RADio:DMODulation:ARB:SETup PHS [:SOURce]:RADio:DMODulation:ARB:SETup? [:SOURce]:RADio:DMODulation:ARB:SETup:MCARrier PHS [:SOURce]:RADio:DMODulation:ARB:SETup:MCARrier?
PSK	[:SOURce]:RADio:DMODulation:ARB:MODulation[:TYPE] BPSK QPSK IS95QPSK GRAYQPSK OQPSK IS95OQPSK P4DQPSK PSK8 PSK16 D8PSK [:SOURce]:RADio:DMODulation:ARB:MODulation[:TYPE]?
PWT	[:SOURce]:RADio:DMODulation:ARB:SETup PWT [:SOURce]:RADio:DMODulation:ARB:SETup? [:SOURce]:RADio:DMODulation:ARB:SETup:MCARrier PWT [:SOURce]:RADio:DMODulation:ARB:SETup:MCARrier?
QAM	[:SOURce]:RADio:DMODulation:ARB:MODulation[:TYPE] QAM16 QAM32 QAM64 QAM256 [:SOURce]:RADio:DMODulation:ARB:MODulation[:TYPE]?
QPSK	[:SOURce]:RADio:DMODulation:ARB:MODulation[:TYPE] QPSK [:SOURce]:RADio:DMODulation:ARB:MODulation[:TYPE]?
QPSK and OQPSK	[:SOURce]:RADio:DMODulation:ARB:MODulation[:TYPE] QPSK IS95QPSK GRAYQPSK OQPSK IS95OQPSK [:SOURce]:RADio:DMODulation:ARB:MODulation[:TYPE]?
Rectangle	[:SOURce]:RADio:DMODulation:ARB:FILTer RECTangle [:SOURce]:RADio:DMODulation:ARB:FILTer?
Retrigger Mode Off On	[:SOURce]:RADio:DMODulation:ARB:RETRigger ON OFF 1 0 [:SOURce]:RADio:DMODulation:ARB:RETRigger?
Root Nyquist	[:SOURce]:RADio:DMODulation:ARB:FILTer RNYQuist [:SOURce]:RADio:DMODulation:ARB:FILTer?

Key	SCPI Command
Select	[:SOURCE]:RADio:DMODulation:ARB:FILTer RNYQuist NYQuist GAUSSsian RECTangle IS95 IS95_EQ IS95_MOD IS95_MOD_EQ WCDMa AC4Fm ISO2000SR3DS [:SOURCE]:RADio:DMODulation:ARB:FILTer?
Select File	[:SOURCE]:RADio:DMODulation:ARB:FILTer "<file name>" [:SOURCE]:RADio:DMODulation:ARB:FILTer?
Setup Select	[:SOURCE]:RADio:DMODulation:ARB:SETup GSM NADC PDC PHS DECT AC4Fm ACQPsk CDPD PWT EDGE TETRa [:SOURCE]:RADio:DMODulation:ARB:SETup?
Single	[:SOURCE]:RADio:DMODulation:ARB:TRIGger:TYPE SINGLE [:SOURCE]:RADio:DMODulation:ARB:TRIGger:TYPE?
Store Custom Dig Mod State	[:SOURCE]:RADio:DMODulation:ARB:SETup:STORE "<file name>"
Symbol Rate	[:SOURCE]:RADio:DMODulation:ARB:SRATE <value> [:SOURCE]:RADio:DMODulation:ARB:SRATE?
TETRA	[:SOURCE]:RADio:DMODulation:ARB:SETup TETRa [:SOURCE]:RADio:DMODulation:ARB:SETup? [:SOURCE]:RADio:DMODulation:ARB:SETup:MCARrier TETRa [:SOURCE]:RADio:DMODulation:ARB:SETup:MCARrier?
Trigger Key	[:SOURCE]:RADio:DMODulation:ARB:TRIGger[:SOURCE] KEY [:SOURCE]:RADio:DMODulation:ARB:TRIGger[:SOURCE]?
Trigger Setup	[:SOURCE]:RADio:DMODulation:ARB:TRIGger:TYPE CONT SINGLE GATE [:SOURCE]:RADio:DMODulation:ARB:TRIGger:TYPE?
Trigger Source	[:SOURCE]:RADio:DMODulation:ARB:TRIGger[:SOURCE] KEY EXT BUS [:SOURCE]:RADio:DMODulation:ARB:TRIGger[:SOURCE]?
User FIR	[:SOURCE]:RADio:DMODulation:ARB:FILTer "<file name>" [:SOURCE]:RADio:DMODulation:ARB:FILTer?
WCDMA	[:SOURCE]:RADio:DMODulation:ARB:FILTer WCDMa [:SOURCE]:RADio:DMODulation:ARB:FILTer?

Symbols

- # of Carriers softkey, 3-3
- # Skipped Points softkey, 3-3

Numerics

- 1048576 softkey, 3-8
- 131072 softkey, 3-8
- 16384 softkey, 3-8
- 16-Lvl FSK softkeys, 3-6
- 16PSK softkey, 3-6
- 16QAM softkey, 3-6
- 2.500 MHz softkey, 3-4
- 250.0 kHz softkey, 3-7
- 256QAM softkey, 3-8
- 262144 softkey, 3-8
- 2-Lvl FSK softkey, 3-4
- 2-Lvl FSK softkeys, 3-4
- 32 Ch Fwd softkey, 3-6
- 32768 softkey, 3-8
- 32QAM softkey, 3-7
- 4-Lvl FSK softkey, 3-4
- 4QAM softkey, 3-4
- 524288 softkey, 3-8
- 64 Ch Fwd softkey, 3-7
- 64QAM softkey, 3-7
- 65536 softkey, 3-8
- 8 bit pattern softkey, 3-5
- 8.000 MHz softkey, 3-4
- 8-Lvl FSK softkeys, 3-5
- 8PSK softkey, 3-5
- 9 Ch Fwd softkey, 3-5

A

- additive white gaussian noise waveforms
 - creating, 2-80
- Adjust Code Domain Power softkey, 3-9
- AM_ADDR softkey, 3-9
- APCO 25 w/C4FM softkey, 3-9
- APCO 25 w/CQPSK softkey, 3-10
- APCO 25 C4FM softkey, 3-9
- Apply Channel Setup softkey, 3-10
- Apply Multicarrier softkey, 3-10
- Apply Multitone softkey, 3-10
- Apply to Waveform softkey, 3-11
- ARB memory
 - downloading waveform files to, 2-72
 - managing, 4-4

ARB memory (Continued)

- types, 4-4
- ARB Off On SCPI command, 5-26
- ARB Off On softkey, 3-12
- ARB Reference Ext Int softkey, 3-12
- ARB reference source SCPI command, 5-2, 5-3, 5-4, 5-5, 5-6, 5-7, 5-26
- ARB Sample Clock softkey, 3-12
- ARB Setup softkey, 3-12
- AWGN
 - creating waveforms, 2-80
 - softkey and SCPI command cross-reference table, 6-2
- AWGN Off On softkey, 3-13
- AWGN softkeys
 - 1048576, 3-8
 - 131072, 3-8
 - 16384, 3-8
 - 262144, 3-8
 - 32768, 3-8
 - 524288, 3-8
 - 65536, 3-8
 - AWGN, 3-13
 - AWGN Off On, 3-13
 - Bandwidth, 3-13
 - Noise Seed Fixed Random, 3-50
 - Plot CCDF, 3-55
 - Waveform Length, 3-73
 - Waveform Statistics, 3-74

B

- Bandwidth softkey, 3-13
- baseband clipping. *See* clipping
- BD_ADDR softkey, 3-14
- Beta softkey, 3-14
- Bluetooth
 - accessing the Bluetooth setup menu, 2-93
 - SCPI commands, 5-2–5-6
 - setting the burst power ramp, 2-97
 - setting up a Bluetooth signal, 2-93
 - setting up impairments, 2-95
 - setting up packet parameters, 2-93
 - softkey and SCPI command cross-reference table, 6-3
 - using burst, 2-96
 - using clock/gate delay, 2-97
- Bluetooth off on softkey, 3-14
- Bluetooth softkeys
 - 8 bit pattern, 3-5
 - Bluetooth, 3-14

Bluetooth softkeys (Continued)

- Bluetooth off on, [3-14](#)
- burst off on, [3-15](#)
- burst power ramp, [3-15](#)
- c/n (1 MHz), [3-20](#)
- clock/gate delay, [3-20](#)
- impairments, [3-40](#)
 - AWGN, [3-13](#)
 - AWGN noise seed, [3-50](#)
 - AWGN off on, [3-13](#)
 - drift deviation, [3-27](#)
 - freq drift type linear sine, [3-35](#)
 - freq offset, [3-35](#)
 - impairments off on, [3-40](#)
- packet (DH1), [3-53](#)
 - AM_ADDR, [3-9](#)
 - BD_ADDR, [3-14](#)
 - continuous PN9, [3-21](#)
 - payload data, [3-54](#)
- BPSK softkey, [3-15](#)
- Build New Waveform Sequence softkey, [3-15](#)
- burst off on softkey, [3-15](#)
- burst power ramp softkey, [3-15](#)
- Bus softkey, [3-16](#)

C

- c/n (1 MHz) softkey, [3-20](#)
- C4FM softkey, [3-16](#)
- Carrier Setup softkey, [3-16](#)
- catalog
 - file types, [2-79](#)
 - I/Q files, [2-52](#)
 - reviewing the memory, [2-79](#)
- CDMA
 - external delay state SCPI command, [5-12](#)
 - external delay time SCPI command, [5-12](#)
 - external polarity SCPI command, [5-12](#)
 - gate active SCPI command, [5-14](#)
 - personality overview, [1-4](#)
 - retrigger mode state SCPI command, [5-16](#)
 - softkey and SCPI command cross-reference table, [6-5](#)
 - state
 - activating new, [2-7](#)
 - applying custom channel setup, [2-7](#)
 - applying custom state to RF output, [2-7](#)
 - creating custom, [2-3](#)
 - modifying a custom template, [2-4](#)
 - recalling custom states, [2-13](#)
 - SCPI command, [5-7](#)
 - setting up a custom template, [2-3](#)
 - storing custom states to memory, [2-11](#)
 - subsystem SCPI commands, [5-7](#)

CDMA (Continued)

- template
 - adding a new channel type, [2-5](#)
 - modifying, [2-4](#)
 - modifying the code domain power, [2-6](#)
 - modifying the data, [2-5](#)
 - modifying the Walsh Code, [2-5](#)
 - setting up, [2-3](#)
- trigger source SCPI command, [5-17](#)
- trigger type SCPI command, [5-17](#)
- waveform trigger, [2-81](#)
- CDMA Define softkey, [3-16](#)
- CDMA Formats softkey, [3-16](#)
- CDMA Off On softkey, [3-17](#)
- CDMA softkeys
 - 2.500 MHz, [3-4](#)
 - 250.0 kHz, [3-7](#)
 - 32 Ch Fwd, [3-6](#)
 - 64 Ch Fwd, [3-7](#)
 - 8.000 MHz, [3-4](#)
 - 9 Ch Fwd, [3-5](#)
 - Adjust Code Domain Power, [3-9](#)
 - Apply Channel Setup, [3-10](#)
 - Apply Multicarrier, [3-10](#)
 - Apply to Waveform, [3-11](#)
 - ARB Reference Ext Int, [3-12](#)
 - Bus, [3-16](#)
 - CDMA Define, [3-16](#)
 - CDMA Formats, [3-16](#)
 - CDMA Off On, [3-17](#)
 - Chip Rate, [3-17](#)
 - Clip |I+jQ| To, [3-18](#)
 - Clip |I| To, [3-18](#)
 - Clip |Q| To, [3-18](#)
 - Clip At PRE POST FIR Filter, [3-19](#)
 - Clipping, [3-19](#)
 - Clipping Type |I+jQ| |I|, |Q|, [3-19](#)
 - Continuous, [3-20](#)
 - Custom CDMA Carrier, [3-21](#)
 - Custom CDMA Multicarrier, [3-21](#)
 - Custom CDMA State, [3-21](#)
 - Define User FIR, [3-22](#)
 - Delete All Rows, [3-23](#)
 - Delete File, [3-23](#)
 - Delete Row, [3-23](#)
 - Display Code Domain Power, [3-25](#)
 - Display FFT, [3-26](#)
 - Display Impulse Response, [3-26](#)
 - Edit Channel Setup, [3-28](#)
 - Edit Item, [3-28](#)
 - Equal Powers, [3-29](#)
 - Ext, [3-29](#)

CDMA softkeys (Continued)

- Ext Delay Off On, 3-30
- Ext Delay Time, 3-30
- Ext Polarity Neg Pos, 3-31
- Filter, 3-31
 - Filter Alpha, 3-31
 - Filter BbT, 3-32
 - Filter Factor N/A, 3-33
 - Filter Symbols, 3-33
- Gate Active Low High, 3-37
- Gate Active N/A, 3-37
- Gated, 3-37
- Gaussian, 3-38
- Goto Bottom Row, 3-39
- Goto Middle Row, 3-39
- Goto Row, 3-39
- Goto Top Row, 3-39
- Insert Row, 3-41
- IS-95, 3-42
 - IS-95 Mod, 3-43
 - IS-95 Mod w/EQ, 3-43
 - IS-95 w/EQ, 3-44
 - IS-95A, 3-42
 - IS-97 Levels, 3-44
- Load Default FIR, 3-46
- Load From Selected File, 3-46
- Load/Store, 3-46
- Mirror Table, 3-47
- Multicarrier Define, 3-48
- Multicarrier Off On, 3-49
- Nyquist, 3-51
- Optimize FIR For EVM ACP, 3-52
- Oversample Ratio, 3-52
- Page Down, 3-53
- Page Up, 3-53
- Paging, 3-53
- Pilot (Setup Select), 3-54
- Plot CCDF, 3-55
- Random, 3-57
- Reconstruction Filter, 3-58
- Rectangle, 3-58
- Reference Frequency, 3-58
- Restore Default Filter, 3-59
- Retrigger Mode Off On, 3-59
- Reverse, 3-60
- Root Nyquist, 3-60
- Scale To 0dB, 3-61
- Select, 3-62
- Select File, 3-62
- Setup Select, 3-65
- Single, 3-66
- Store Custom CDMA State, 3-67

CDMA softkeys (Continued)

- Store Custom Multicarrier, 3-68
- Store To File, 3-69
- Sync, 3-70
 - Through, 3-70
- Traffic, 3-71
- Trigger, 3-71
- Trigger Key, 3-72
- Trigger Setup, 3-72
- Trigger Source, 3-72
- User FIR, 3-73
- Waveform Length, 3-73
- Waveform Statistics, 3-74

CDPD softkey, 3-17

channel setup SCPI command, 5-8

chip rate SCPI command, 5-9

Chip Rate softkey, 3-17

circular clipping, 4-13

clipping

- CDMA waveforms, 2-8
- circular, 4-13
- concepts, 4-10
- FIR filtering options, 4-15
- intermodulation distortion, 4-12
- peak-to-average power, 4-13
- power peaks, 4-10
- rectangular, 4-13
- SCPI commands
 - clipping level, $|I+jQ|$, 5-10
 - clipping level, $|I|$, 5-10
 - clipping level, $|Q|$, 5-10
 - clipping waveform segments, 5-26
 - pre/post FIR filter, 5-10
 - type, 5-10

softkeys

- Apply to Waveform, 3-11
- Clip $|I+jQ|$ To, 3-18
- Clip $|I|$ To, 3-18
- Clip $|Q|$ To, 3-18
- Clip At PRE POST FIR Filter, 3-19
- Clipping, 3-19
- Clipping Type $|I+jQ|$ $|I|$, $|Q|$, 3-19

spectral regrowth, 4-12

using, 2-8

waveform segments, 2-70

clock/gate delay softkey, 3-20

code domain power, viewing, 2-9

coefficient values, entering in FIR table editor, 2-36

continuous PN9 softkey, 3-21

Continuous softkey, 3-20

create waveform sequence SCPI command, 5-27

creating a multitone waveform, 5-33

cross-reference table

- AWGN, [6-2](#)
- Bluetooth, [6-3](#)
- CDMA, [6-5](#)
- Digital Modulation, [6-15](#)
- Dual ARB, [6-10](#)
- IS-95A, [6-5](#)
- Multitone, [6-14](#)
- Other Formats, [6-15](#)
- Custom CDMA Multicarrier softkey, [3-21](#)
- Custom CDMA State softkey, [3-21](#)
- custom CDMA states
 - creating, [2-3](#)
 - recalling, [2-13](#)
 - store SCPI command, [5-11](#)
 - storing, [2-11](#)
- Custom Digital Mod State softkey, [3-22](#)
- custom multicarrier CDMA waveforms
 - applying and activating, [2-21](#)
 - creating, [2-15](#)
 - recalling, [2-25](#)
 - storing, [2-23](#)
- custom multicarrier, store SCPI command, [5-11](#)
- Custom Softkeys
 - Custom CDMA Multicarrier, [3-21](#)
- Custom softkeys
 - Custom CDMA Carrier, [3-21](#)

D

- D8PSK softkey, [3-22](#)
- DECT softkey, [3-22](#)
- define user FIR SCPI command, [5-17](#)
- Define User FIR softkey, [3-22](#)
- defining a waveform sequence, [5-30](#)
- Delete All ARB Files softkey, [3-23](#)
- Delete All NVARB Files softkey, [3-23](#)
- Delete All Rows softkey, [3-23](#)
- Delete File softkey, [3-23](#)
- Delete Row softkey, [3-23](#)
- Delete Segment softkey, [3-24](#)
- Delete Selected Waveform softkey, [3-24](#)
- Delete Waveform Sequence softkey, [3-24](#)
- Digital Mod Define softkey, [3-24](#)
- Digital Modulation
 - softkey and SCPI command cross-reference table, [6-15](#)
- digital modulation
 - setting up custom single carrier, [2-29](#)
 - setting up multicarrier, [2-33](#)
 - setting up predefined single carrier, [2-27](#)

- Digital Modulation Off On softkey, [3-24](#)
- Digital Modulation SCPI commands, [5-18–5-25](#)
 - define user FIR, [5-18](#)
 - digital modulation setup, [5-18](#)
 - digital modulation state, [5-18](#)
 - external delay state, [5-19](#)
 - external delay time, [5-19](#)
 - external polarity, [5-19](#)
 - filter alpha, [5-19](#)
 - filter BbT, [5-20](#)
 - filter optimization, [5-20](#)
 - filter selection, [5-20](#)
 - FSK frequency deviation, [5-21](#)
 - gate active polarity, [5-21](#)
 - Gaussian filter BbT, [5-20](#)
 - loading multicarrier user file, [5-23](#)
 - modulation type, [5-21](#)
 - multicarrier setup, [5-22](#)
 - multicarrier table setup, [5-23](#)
 - number of multicarriers, [5-23](#)
 - Nyquist filter alpha, [5-19](#)
 - retrigger mode state, [5-24](#)
 - store custom modulation file, [5-24](#)
 - store multicarrier file, [5-24](#)
 - symbol rate, [5-24](#)
 - Toot Nyquist filter alpha, [5-19](#)
 - trigger source, [5-25](#)
 - trigger type, [5-25](#)
- Digital Modulation softkeys
 - # of Carriers, [3-3](#)
 - 16-Lvl FSK, [3-6](#)
 - 16PSK, [3-6](#)
 - 16QAM, [3-6](#)
 - 256QAM, [3-8](#)
 - 2-Lvl FSK, [3-4](#)
 - 32QAM, [3-7](#)
 - 4-Lvl FSK, [3-4](#)
 - 4QAM, [3-4](#)
 - 64QAM, [3-7](#)
 - 8-Lvl FSK, [3-5](#)
 - 8PSK, [3-5](#)
 - APCO 25 w/C4FM, [3-9](#)
 - APCO 25 w/CQPSK, [3-10](#)
 - APCO 25 C4FM, [3-9](#)
 - Apply Multicarrier, [3-10](#)
 - Beta, [3-14](#)
 - BPSK, [3-15](#)
 - Bus, [3-16](#)
 - C4FM, [3-16](#)
 - Carrier Setup, [3-16](#)
 - CDPD, [3-17](#)
 - Continuous, [3-20](#)

Digital Modulation softkeys (Continued)

Custom Digital Mod State, [3-22](#)
D8PSK, [3-22](#)
DECT, [3-22](#)
Define User FIR, [3-22](#)
Delete Row, [3-23](#)
Digital Mod Define, [3-24](#)
Digital Modulation Off On, [3-24](#)
Display FFT, [3-26](#)
Display Impulse Response, [3-26](#)
EDGE, [3-28](#)
Edit Item, [3-28](#)
Ext, [3-29](#)
Ext Delay Off On, [3-30](#)
Ext Delay Time, [3-30](#)
Ext Polarity Neg Pos, [3-31](#)
Filter, [3-31](#)
Filter Alpha, [3-31](#)
Filter Bbt, [3-32](#)
Filter Factor N/A, [3-33](#)
Filter Symbols, [3-33](#)
Freq Dev, [3-35](#)
Freq Spacing, [3-36](#)
FSK, [3-36](#)
Gate Active Low High, [3-37](#)
Gate Active N/A, [3-37](#)
Gated, [3-37](#)
Gaussian, [3-38](#)
Generate, [3-38](#)
Gray Coded QPSK, [3-39](#)
GSM, [3-39](#)
Hamming, [3-40](#)
Hann, [3-40](#)
Initialize Table, [3-41](#)
Insert Row, [3-41](#)
IS-2000 SR3 DS, [3-44](#)
IS-95, [3-42](#)
IS-95 and IS-2000, [3-42](#)
IS-95 Mod, [3-43](#)
IS-95 Mod w/EQ, [3-43](#)
IS95 OQPSK, [3-43](#)
IS95 QPSK, [3-44](#)
IS-95 \ w/EQ, [3-44](#)
Kaiser, [3-44](#)
Load Default FIR, [3-46](#)
Load/Store, [3-46](#)
Mirror Table, [3-47](#)
Modulation Type, [3-48](#)
MSK, [3-48](#)
Multicarrier Define, [3-48](#)
Multicarrier Off On, [3-49](#)
NADC, [3-49](#)
None, [3-50](#)
Nyquist, [3-51](#)

Digital Modulation softkeys (Continued)

Optimize FIR For EVM ACP, [3-52](#)
OQPSK, [3-52](#)
Oversample Ratio, [3-52](#)
 $\pi/4$ DQPSK, [3-3](#)
PDC, [3-54](#)
PHS, [3-54](#)
PSK, [3-56](#)
PWT, [3-56](#)
QAM, [3-56](#)
QPSK, [3-57](#)
QPSK and OQPSK, [3-57](#)
Rectangle, [3-58](#)
Restore Default Filter, [3-59](#)
Retrigger Mode Off On, [3-59](#)
Root Nyquist, [3-60](#)
Setup Select, [3-65](#)
Single, [3-66](#)
Store Custom Digital Mod State, [3-68](#)
Symbol Rate, [3-69](#)
TETRA, [3-70](#)
Trigger, [3-71](#)
Trigger Key, [3-72](#)
Trigger Setup, [3-72](#)
Trigger Source, [3-72](#)
User FIR, [3-73](#)
Waveform Statistics, [3-74](#)
WCDMA, [3-75](#)
Window, [3-75](#)
Display Code Domain Power softkey, [3-25](#)
Display Code Domain Power softkeys
 Next PN Offset, [3-50](#)
 Previous PN Offset, [3-56](#)
Display FFT softkey, [3-26](#)
Display Impulse Response softkey, [3-26](#)
Done Inserting softkey, [3-27](#)
Done softkey, [3-27](#)
downloading waveforms, [2-72](#)
 interruptions, [2-78](#)
drift deviation softkey, [3-27](#)
Dual ARB
 external delay state SCPI command, [5-27](#)
 external delay time SCPI command, [5-27](#)
 external polarity SCPI command, [5-27](#)
 gate active SCPI command, [5-28](#)
 retrigger mode state SCPI command, [5-31](#)
 softkey and SCPI command cross-reference table,
 [6-10](#)
 subsystem SCPI commands, [5-26](#)
 trigger source SCPI command, [5-31](#)
 trigger type SCPI command, [5-32](#)
 waveform generator overview, [1-2](#)

Dual ARB softkeys (Continued)

- # Skipped Points, 3-3
- 2.500 MHz, 3-4
- 250.0 kHz, 3-7
- 8.000 MHz, 3-4
- Apply to Waveform, 3-11
- ARB Off On, 3-12
- ARB Reference Ext Int, 3-12
- ARB Sample Clock, 3-12
- ARB Setup, 3-12
- Build New Waveform Sequence, 3-15
- Bus, 3-16
- Clip |I+jQ| To, 3-18
- Clip |I| To, 3-18
- Clip |Q| To, 3-18
- Clipping, 3-19
- Clipping Type |I+jQ| |I|, |Q|, 3-19
- Continuous, 3-20
- Delete All ARB Files, 3-23
- Delete All NVARB Files, 3-23
- Delete Segment, 3-24
- Delete Selected Waveform, 3-24
- Delete Waveform Sequence, 3-24
- Done Inserting, 3-27
- Dual ARB, 3-27
- Edit Repetitions, 3-29
- Edit Selected Waveform Sequence, 3-29
- Ext, 3-29
- Ext Delay Off On, 3-30
- Ext Delay Time, 3-30
- Ext Polarity Neg Pos, 3-31
- First Mkr Point, 3-34
- Gate Active Low High, 3-37
- Gate Active N/A, 3-37
- Gated, 3-37
- Insert Selected Waveform, 3-41
- Insert Waveform, 3-41
- Insert Waveform Sequence Contents, 3-42
- Last Mkr Point 1, 3-45
- Load Store, 3-46
- Marker 1 2, 3-47
- Marker Polarity Neg Pos, 3-47
- Mkr 2 To RF Blank Off On, 3-47
- Name And Store, 3-50
- Plot CCDF, 3-55
- Reconstruction Filter, 3-58
- Reference Frequency, 3-58
- Rename Segment, 3-59
- Retrigger Mode Off On, 3-59
- Scaling, 3-61
- Segment Advance, 3-61
- Select Waveform, 3-62
- Select Waveform (ARBI:/SEQ:), 3-62

Dual ARB softkeys (Continued)

- Set Marker Off All Points, 3-63
- Set Marker Off Range of Points, 3-63
- Set Marker On First Point, 3-63
- Set Marker On Range of Points, 3-64
- Set Markers, 3-64
- Set Scaling, 3-64
- Show Waveform Sequence Contents, 3-66
- Single, 3-66
- Store All, 3-67
- Store Segment, 3-69
- Through, 3-70
- Toggle Marker 1, 3-70
- Toggle Marker 2, 3-71
- Toggle Markers, 3-71
- Trigger, 3-71
- Trigger Key, 3-72
- Trigger Setup, 3-72
- Trigger Source, 3-72
- Waveform Segments, 3-74
- Waveform Sequences, 3-74
- Waveform Statistics, 3-74
- Waveform Utilities, 3-74

E

- EDGE softkey, 3-28
- Edit Channel Setup softkey, 3-28
- Edit Item softkey, 3-28
- Edit Repetitions softkey, 3-29
- Edit Selected Waveform Sequence softkey, 3-29
- Enter softkey, 3-29
- Equal Powers softkey, 3-29
- EVENT 1 markers, 4-6
- EVENT 2 markers, 4-6
- example program
 - channel setup, 5-9
- Ext Delay Off On softkey, 3-30
- Ext Delay Time softkey, 3-30
- Ext Polarity Neg Pos softkey, 3-31
- Ext softkey, 3-29
- external reconstruction filters, using, 2-45
- external trigger, 2-81

F

- files
 - I/Q files catalog, 2-52
 - loading FIR filter, 2-40
- filter
 - displaying a graph, 2-38
 - external reconstruction, 2-45

filter (Continued)

- FIR filter
 - clipping options, [4-15](#)
 - modifying a, [2-40](#)
 - storing to memory, [2-39](#), [2-42](#)
- Filter Alpha softkey, [3-31](#)
- Filter BbT softkey, [3-32](#)
- Filter Factor N/A softkey, [3-33](#)
- filter SCPI commands
 - alpha, [5-12](#)
 - BbT, [5-13](#)
 - optimization, [5-14](#)
 - selection, [5-13](#)
- Filter softkey, [3-31](#)
- Filter Symbols softkey, [3-33](#)
- FIR filter
 - applying a custom filter to a CDMA state, [2-43](#)
 - user-defined, [2-35](#)
- FIR table editor
 - accessing, [2-35](#)
 - duplicating coefficients using mirror table, [2-37](#)
 - entering coefficient values, [2-36](#)
 - loading an existing FIR file, [2-40](#)
 - modifying an FIR filter, [2-40](#)
 - modifying the coefficients, [2-41](#)
 - setting the oversample ratio, [2-37](#)
 - storing the filter to memory, [2-39](#), [2-42](#)
 - using to create user-defined FIR filter, [2-35](#)
- First Mkr Point softkey, [3-34](#)
- Freq Dev softkey, [3-35](#)
- freq drift type linear sine softkey, [3-35](#)
- freq offset softkey, [3-35](#)
- Freq Spacing softkey, [3-36](#)
- frequency spacing between tones, [5-34](#)
- FSK softkey, [3-36](#)

G

- Gate Active Low High softkey, [3-37](#)
- Gate Active N/A softkey, [3-37](#)
- Gated softkey, [3-37](#)
- Gaussian softkey, [3-38](#)
- Generate softkey, [3-38](#)
- Goto Bottom Row softkey, [3-39](#)
- Goto Middle Row softkey, [3-39](#)
- Goto Row softkey, [3-39](#)
- Goto Top Row softkey, [3-39](#)
- graph, displaying a filter, [2-38](#)
- Gray Coded QPSK softkey, [3-39](#)
- GSM softkey, [3-39](#)

H

- Hamming softkey, [3-40](#)
- Hann softkey, [3-40](#)
- hardkey, Mode, [3-2](#)

I

- impairments off on softkey, [3-40](#)
- impairments softkey, [3-40](#)
- Initialize Phase Fixed Random softkey, [3-40](#)
- Initialize Table softkey, [3-41](#)
- initializing multitone waveform setup table, [5-33](#)
- Insert Row softkey, [3-41](#)
- Insert Selected Waveform softkey, [3-41](#)
- Insert Waveform Sequence Contents softkey, [3-42](#)
- Insert Waveform softkey, [3-41](#)
- intermodulation distortion, [4-10](#), [4-12](#)
- IS-95 and IS-2000 softkey, [3-42](#)
- IS-95 Mod softkey, [3-43](#)
- IS-95 Mod w/EQ softkey, [3-43](#)
- IS95 OQPSK softkey, [3-43](#)
- IS95 QPSK softkey, [3-44](#)
- IS-95 softkey, [3-42](#)
- IS-95 w/EQ softkey, [3-44](#)
- IS-95A
 - softkey and SCPI command cross-reference table, [6-5](#)
- IS-95A softkey, [3-42](#)
- IS-97 Levels softkey, [3-44](#)

K

- Kaiser softkey, [3-44](#)
- key descriptions, [3-1](#)

L

- Last Mkr Point 1 softkey, [3-45](#)
- Load Default FIR softkey, [3-46](#)
- Load From Selected File softkey, [3-46](#)
- Load Store softkey, [3-46](#)
- Load/Store softkey, [3-46](#)
- loading a FIR filter file, [2-40](#)
- loading a multitone waveform, [5-35](#)

M

- marker softkeys
 - # Skipped Points, [3-3](#)
 - Apply to Waveform, [3-11](#)
 - First Mkr Point, [3-34](#)

marker softkeys (Continued)

- Last Mkr Point 1, [3-45](#)
- Marker 1 2, [3-47](#)
- Marker Polarity Neg Pos, [3-47](#)
- Mkr 2 To RF Blank Off On, [3-47](#)
- Set Marker Off All Points, [3-63](#)
- Set Marker Off Range of Points, [3-63](#)
- Set Marker On First Point, [3-63](#)
- Set Marker On Range of Points, [3-64](#)
- Set Markers, [3-64](#)
- Toggle Marker 1, [3-70](#)
- Toggle Marker 2, [3-71](#)
- Toggle Markers, [3-71](#)

markers

- clearing, [5-29](#)
- defining of a range of points, [5-28](#)
- SCPI commands, [5-28–5-30](#)
- setting marker 2 to blank RF output, [5-29](#)
- setting polarity, [5-29](#)
- toggling, [5-30](#)
- toggling in existing waveform sequences, [2-66](#)
- toggling while creating a waveform sequence, [2-67](#)
- using, [2-61–2-67](#)

memory catalog file types, [2-79](#)

memory catalog, reviewing, [2-79](#)

memory, managing ARB and NVARB, [4-4](#)

mirror table

- duplicating coefficients, [2-37](#)

Mirror Table softkey, [3-47](#)

Mkr 2 To RF Blank Off On softkey, [3-47](#)

mode

- AWGN softkeys and SCPI commands, [6-2](#)
- Bluetooth softkeys and SCPI commands, [6-3](#)
- CDMA softkeys and SCPI commands, [6-5](#)
- Digital Modulation softkeys and SCPI commands, [6-15](#)
- Dual ARB softkeys and SCPI commands, [6-10](#)
- IS-95A softkeys and SCPI commands, [6-5](#)
- Multitone softkeys and SCPI commands, [6-14](#)
- Other Formats softkeys and SCPI commands, [6-15](#)

Mode hardkey, [3-2](#)

Modulation Type softkey, [3-48](#)

modulation, activating via GPIB, [2-78](#)

MSK softkey, [3-48](#)

MTONE softkey, [3-48](#)

multicarrier CDMA

- applying custom waveforms to RF output, [2-22](#)
- creating a custom waveform, [2-15](#)
- modifying a template, [2-17](#)
- personality overview, [1-4](#)
- recalling custom waveforms, [2-25](#)

multicarrier CDMA (Continued)

- storing custom waveforms to memory, [2-23](#)

- table editor, [2-16](#)

- waveform trigger, [2-81](#)

multicarrier CDMA waveforms

- modifying a multicarrier CDMA template, [2-17](#)

multicarrier define SCPI command, [5-14](#)

Multicarrier Define softkey, [3-48](#)

multicarrier digital modulation

- setting up, [2-33](#)

Multicarrier Off On softkey, [3-49](#)

multicarrier setup select SCPI command, [5-15](#)

multichannel CDMA personality overview, [1-4](#)

multitone

- defining individual tone parameters, [5-34](#)

- softkey and SCPI command cross-reference table, [6-14](#)

- updating a waveform, [2-46](#), [2-53](#)

Multitone softkeys

- Apply Multitone, [3-10](#)

- Delete File, [3-23](#)

- Done, [3-27](#)

- Enter, [3-29](#)

- Freq Spacing, [3-36](#)

- Goto Bottom Row, [3-39](#)

- Goto Middle Row, [3-39](#)

- Goto Row, [3-39](#)

- Goto Top Row, [3-39](#)

- Initialize Phase Fixed Random, [3-40](#)

- Initialize Table, [3-41](#)

- Load From Selected File, [3-46](#)

- Load/Store, [3-46](#)

- MTONE, [3-48](#)

- Multitone, [3-49](#)

- Multitone Off On, [3-49](#)

- Number of Tones, [3-51](#)

- Page Down, [3-53](#)

- Page Up, [3-53](#)

- Plot CCDF, [3-55](#)

- Random Seed Fixed Random, [3-57](#)

- Store To File, [3-69](#)

- Toggle State, [3-71](#)

- Waveform Statistics, [3-74](#)

multitone table editor overview, [2-46](#)

multitone waveform

- assigning frequency spacing, [5-34](#)

- creating a, [2-47](#), [5-33](#)

- defining the number of tones, [5-34](#)

- generator, using the, [2-46–2-53](#)

- initializing a setup table, [5-33](#)

- loading a stored waveform, [2-52](#)

multitone waveform (Continued)

- retrieving a, [5-35](#)
- SCPI commands, [5-33–5-36](#)
- storing a, [5-35](#)
- turning on/off, [5-35](#)

N

- NADC softkey, [3-49](#)
- Name And Store softkey, [3-50](#)
- naming a waveform sequence, [2-59](#)
- Next PN Offset softkey, [3-50](#)
- Noise Seed Fixed Random softkey, [3-50](#)
- noise seed softkey, [3-50](#)
- None softkey, [3-50](#)
- Number of Tones softkey, [3-51](#)
- number of tones, defining, [5-34](#)
- NVARB memory, managing, [4-4](#)
- Nyquist softkey, [3-51](#)

O

- Optimize FIR For EVM ACP softkey, [3-52](#)
- OQPSK softkey, [3-52](#)
- Other Formats
 - softkey and SCPI command cross-reference table, [6-15](#)
- oversample ratio SCPI command, [5-15](#)
- Oversample Ratio softkey, [3-52](#)
- oversample ratio, setting, [2-37](#)

P

- $\pi/4$ DQPSK softkey, [3-3](#)
- packet (DH1) softkey, [3-53](#)
- Page Down softkey, [3-53](#)
- Page Up softkey, [3-53](#)
- Paging softkey, [3-53](#)
- payload data softkey, [3-54](#)
- PDC softkey, [3-54](#)
- peak-to-average power, [4-13](#)
- phase, defining a tone's, [5-34](#)
- PHS softkey, [3-54](#)
- Pilot (Setup Select) softkey, [3-54](#)
- placing a marker
 - across a range of points, [2-63](#)
 - at beginning of waveform segment, [2-63](#)
 - on a waveform segment, [2-61](#)
 - repetitively-spaced markers, [2-64](#)

- playback
 - controlling waveform sequence, [2-86](#)
- Plot CCDF softkey, [3-55](#)
- PN Offset softkey, [3-55](#)
- power
 - clipping peaks, [4-10](#)
 - power level, defining a tone's, [5-34](#)
- Previous PN Offset softkey, [3-56](#)
- Primary Key softkey, [3-56](#)
- programming command cross-reference, [6-1](#)
- programming example
 - channel setup, [5-9](#)
- PSK softkey, [3-56](#)
- PWT softkey, [3-56](#)

Q

- QAM softkey, [3-56](#)
- QPSK and OQPSK softkey, [3-57](#)
- QPSK softkey, [3-57](#)

R

- Random Seed Fixed Random softkey, [3-57](#)
- Random softkey, [3-57](#)
- reconstruction filter SCPI command, [5-15, 5-30](#)
- Reconstruction Filter softkey, [3-58](#)
- reconstruction filters, external, [2-45](#)
- Rectangle softkey, [3-58](#)
- rectangular clipping, [4-13](#)
- reference frequency SCPI command, [5-16, 5-30](#)
- Reference Frequency softkey, [3-58](#)
- Rename Segment softkey, [3-59](#)
- Restore Default Filter softkey, [3-59](#)
- retrieving a multitone waveform, [5-35](#)
- retrigger mode, [4-9](#)
- Retrigger Mode Off On softkey, [3-59](#)
- Reverse softkey, [3-60](#)
- RF modulation
 - Option UND, [4-2](#)
- RF output
 - blank using marker 2, [2-64](#)
 - blanking using marker 2, [5-29](#)
- Root Nyquist softkey, [3-60](#)

S

- sample clock SCPI command, [5-31](#)
- Scale To 0dB softkey, [3-61](#)
- scaling SCPI command, [5-31](#)

- Scaling softkey, [3-61](#), [3-64](#)
 - scaling softkeys
 - Apply to Waveform, [3-11](#)
 - scaling waveform segments, [2-68](#)
 - SCPI commands
 - CDMA subsystem reference, [5-7](#)
 - cross-reference, [6-1](#)
 - Dual ARB subsystem reference, [5-26](#)
 - Secondary Key softkey, [3-61](#)
 - Segment Advance softkey, [3-61](#)
 - Select File softkey, [3-62](#)
 - Select Waveform (ARBI:/SEQ:) softkey, [3-62](#)
 - select waveform SCPI command, [5-31](#)
 - Select Waveform softkey, [3-62](#)
 - Set Marker Off All Points softkey, [3-63](#)
 - Set Marker Off Range of Points softkey, [3-63](#)
 - Set Marker On First Point softkey, [3-63](#)
 - Set Marker On Range of Points softkey, [3-64](#)
 - Set Markers softkey, [3-64](#)
 - Set Scaling softkey, [3-64](#)
 - setup select SCPI command, [5-16](#)
 - Setup Select softkey, [3-65](#)
 - setup table
 - initializing multitone waveform, [5-33](#)
 - Show Waveform Sequence Contents softkey, [3-66](#)
 - single carrier digital modulation
 - custom, [2-29](#)
 - predefined, [2-27](#)
 - setting up custom, [2-29](#)
 - setting up predefined, [2-27](#)
 - Single softkey, [3-66](#)
 - softkeys
 - descriptions, [3-1](#)
 - See also* individual softkeys
 - Sort softkey, [3-66](#)
 - Sort Table softkey, [3-67](#)
 - Sorting softkeys
 - PN Offset, [3-55](#)
 - Primary Key, [3-56](#)
 - Secondary Key, [3-61](#)
 - Sort Table, [3-67](#)
 - Walsh Code, [3-73](#)
 - spectral regrowth, [4-10](#), [4-12](#)
 - state
 - defining a tone's on/off, [5-34](#)
 - statistics, viewing waveform, [2-9](#)
 - Store All softkey, [3-67](#)
 - Store Custom CDMA State softkey, [3-67](#)
 - Store Custom Digital Mod State softkey, [3-68](#)
 - store custom multicarrier SCPI command, [5-11](#)
 - Store Custom Multicarrier softkey, [3-68](#)
 - Store Segment softkey, [3-69](#)
 - Store To File softkey, [3-69](#)
 - storing
 - a filter to memory, [2-39](#), [2-42](#)
 - a multitone waveform, [5-35](#)
 - a waveform sequence, [2-59](#)
 - custom CDMA state SCPI command, [5-11](#)
 - Symbol Rate softkey, [3-69](#)
 - Sync softkey, [3-70](#)
- ## T
- table
 - AWGN cross-reference, [6-2](#)
 - Bluetooth cross-reference, [6-3](#)
 - CDMA cross-reference, [6-5](#)
 - Digital Modulation cross-reference, [6-15](#)
 - Dual ARB cross-reference, [6-10](#)
 - IS-95A cross-reference, [6-5](#)
 - Multitone cross-reference, [6-14](#)
 - Other Formats cross-reference, [6-15](#)
 - table editors
 - editing basics, [2-2](#)
 - multicarrier CDMA, [2-16](#)
 - multitone overview, [2-46](#)
 - TETRA softkey, [3-70](#)
 - Through softkey, [3-70](#)
 - Toggle Marker 1 softkey, [3-70](#)
 - Toggle Marker 2 softkey, [3-71](#)
 - Toggle Markers softkey, [3-71](#)
 - Toggle State softkey, [3-71](#)
 - toggle markers, [5-30](#)
 - in an existing waveform sequence, [2-66](#)
 - while creating a waveform sequence, [2-67](#)
 - tone parameters, defining the multitone, [5-34](#)
 - tones, defining the number of multitone, [5-34](#)
 - Traffic softkey, [3-71](#)
 - transferring waveforms, [2-77](#)
 - Trigger Key softkey, [3-72](#)
 - Trigger Setup softkey, [3-72](#)
 - Trigger softkey, [3-71](#)
 - Trigger softkeys
 - Bus, [3-16](#)
 - Continuous, [3-20](#)
 - Ext, [3-29](#)
 - Ext Delay Off On, [3-30](#)
 - Ext Delay Time, [3-30](#)
 - Ext Polarity Neg Pos, [3-31](#)
 - Gate Active Low High, [3-37](#)

Trigger softkeys (Continued)

- Gate Active N/A, [3-37](#)
- Gated, [3-37](#)
- Single, [3-66](#)
- Trigger, [3-71](#)
- Trigger Key, [3-72](#)
- Trigger Setup, [3-72](#)
- Trigger Source, [3-72](#)
- Trigger Source softkey, [3-72](#)
- trigger types, [4-8](#), [4-9](#)
- triggers
 - understanding, [4-8](#)
 - using, [2-81](#)–[2-92](#)
 - using advanced, [2-86](#)
- turning on a Bluetooth signal, [2-97](#)

U

- user files
 - I/Q files catalog, [2-52](#)
 - reviewing the memory catalog, [2-79](#)
- User FIR softkey, [3-73](#)
- user-defined FIR filter, creating a, [2-35](#)

V

- viewing code domain power and waveform statistics, [2-9](#)
- volatile ARB waveform memory, [4-5](#)

W

- Walsh Code softkey, [3-73](#)
- waveform
 - ARB waveform memory types, [4-4](#)
 - clipping segments, [2-70](#)
 - composition, [4-6](#)
 - controlling sequence playback, [2-86](#)
 - copying from ARB to NVARB, [2-77](#)
 - copying from NVARB to ARB, [2-77](#)
 - downloading
 - into memory, [2-72](#)
 - using BASIC for UNIX, [2-75](#)
 - using BASIC for Windows (TM), [2-73](#)
 - using RMB for UNIX, [2-75](#)
 - waveform files into ARB memory, [2-72](#)
 - length SCPI command, [5-17](#)
 - limitations, [4-7](#)
 - loading a stored multitone, [2-52](#)
 - memory and CDMA formats, [4-4](#)
 - querying file data, [2-73](#)
 - scaling segments, [2-68](#)
 - selecting via GPIB, [2-78](#)

waveform (Continued)

- size and available memory, [4-5](#), [4-6](#)
- transferring between ARB and NVARB memory, [2-77](#)
- viewing statistics, [2-9](#)
- waveform generator overview, dual arbitrary, [1-2](#)
- Waveform Length softkey, [3-73](#)
- waveform segments
 - clipping SCPI command, [5-26](#)
- Waveform Segments softkey, [3-74](#)
- waveform sequences
 - building, [2-54](#)
 - building from two waveform segments, [2-57](#)
 - defining, [5-30](#)
 - editing first and second waveform segment repetitions, [2-58](#)
 - generating a waveform, [2-54](#), [2-56](#)
 - naming and storing, [2-59](#)
 - playing, [2-60](#)
 - renaming a waveform segment, [2-55](#)
- Waveform Sequences softkey, [3-74](#)
- Waveform Statistics softkey, [3-74](#)
- Waveform Utilities softkey, [3-74](#)
- Window softkey, [3-75](#)